

CITY OF MORENO VALLEY STANDARD PLANS

SECTION 5

LANDSCAPING AND IRRIGATION SYSTEMS

City of Moreno Valley

Standard Plans Index - 2017 Edition (with Updates November 2019)

SECTION 4: Street Light and Traffic (Continued)

MVLT-450C-0	<i>Traffic Induction Loops Wiring Details</i>
MVLT-460-0	<i>Type 333 Controller Cabinet Foundation Detail</i>
MVLT-461-0	<i>Dual Meter Traffic Signal Service Foundation</i>

Note: *Various State's Standards for Street Light and Traffic may be used subject to review and approval from the Public Works Director/City Engineer.*

SECTION 5: Landscaping and Irrigation Systems

Landscaping

MVLI-500A-0	<i>Palm Tree Planting (Special Districts)</i>
MVLI-500B-1	<i>Palm Tree Planting (Parks & CS)</i>
MVLI-501A-0	<i>Container Planting (Special Districts)</i>
MVLI-501B-1	<i>Container Planting (Shrub Beds) (Parks & CS)</i>
MVLI-501C-0	<i>Container Planting on Slope (Special Districts)</i>
MVLI-501D-1	<i>Container Planting on Slope (Parks & CS)</i>
MVLI-502-1	<i>Native Shrub Planting/On Slope Shrub Planting (Parks & CS)</i>
MVLI-503A-0	<i>Vine Detail: Non-Adhering Type (Special Districts)</i>
MVLI-503B-0	<i>Vine Detail: Adhering Type (Parks & CS)</i>
MVLI-504-0	<i>Tree Spacing Requirements (Special Districts)</i>
MVLI-505A-0	<i>Shrub/Groundcover Spacing (Special Districts)</i>
MVLI-505B-0	<i>Shrub/Groundcover Spacing (Parks & CS)</i>
MVLI-510A-0	<i>Tree Guying Detail - 36" Box or Larger (Special Districts)</i>
MVLI-510B-1	<i>Tree Guying Detail - 36" Box or Larger (Parks & CS)</i>
MVLI-511A-0	<i>Typical Double Stake Tree (15 Gal. - 24" Box) (Special Districts)</i>
MVLI-511B-1	<i>Typical Double Stake Tree (Parks & CS)</i>
MVLI-511C-1	<i>Steel Double Stake Tree (Parks & CS)</i>
MVLI-511D-0	<i>Double Stake Tree on Slope (Special Districts)</i>
MVLI-511E-1	<i>Double Stake Tree on Slope (Parks & CS)</i>
MVLI-512A-0	<i>Triple Stake Tree (Special Districts)</i>
MVLI-512B-1	<i>Triple Stake Tree (Parks & CS)</i>
MVLI-512C-0	<i>Triple Stake Tree on Slope (Special Districts)</i>
MVLI-512D-1	<i>Triple Stake Tree on Slope (Parks & CS)</i>
MVLI-520A-0	<i>Mulch Installation (Special Districts)</i>
MVLI-520B-0	<i>Bark Installation (Parks & CS)</i>
MVLI-521-0	<i>2" x 4" Redwood Header (Special Districts)</i>
MVLI-522A-0	<i>6" Wide Concrete Mow Curb (Special Districts)</i>
MVLI-522B-0	<i>6" Wide Concrete Mow Curb (Parks & CS)</i>
MVLI-522C-0	<i>12" Wide Concrete Mow Curb (Parks & CS)</i>
MVLI-523A-0	<i>Erosion Control Netting (Landscaping) (Special Districts)</i>
MVLI-523B-0	<i>Erosion Control Netting (Landscaping) (Parks & CS)</i>
MVLI-524A-0	<i>Linear Root Barrier (Special Districts)</i>
MVLI-524B-0	<i>Linear Root Barrier (Parks & CS)</i>

City of Moreno Valley

Standard Plans Index - 2017 Edition (with Updates November 2019)

SECTION 5: Landscaping and Irrigation Systems (Continued)

Irrigation

MVLI-530-0	CCU Radio Link Antenna & Enclosure Detail (Special Districts)
MVLI-531A-0	Controller / Satellite Enclosure Detail (Special Districts)
MVLI-531B-0	Smart Controller Enclosure Detail (Parks & CS)
MVLI-532-0	CCU Enclosure Detail (Special Districts)
MVLI-533-0	External Ground Rod Assembly Detail (Special Districts)
MVLI-534-0	LEIT XRC Irrigation Controller (Parks & CS)
MVLI-535-0	Multiple Controllers Using One ET Gage (Parks & CS)
MVLI-536-0	Typical Transient Protection Installation (Parks & CS)
MVLI-537-0	Vandal Resistant ET Gage Enclosure (Parks & CS)
MVLI-538-0	Irrigation Controller Grounding Instruction (Parks & CS)
MVLI-539-0	Irrigation Controller Enclosure Installation Detail (Parks & CS)
MVLI-540A-0	Flow Sensor Assembly Detail (Special Districts)
MVLI-540B-0	Flow Sensor Assembly Detail (Parks & CS)
MVLI-540C-0	FMBX Flow Meter Installation (Parks & CS)
MVLI-541-0	Rain Gauge / Weather Sensor Installation Detail (Parks & CS)
MVLI-542A-0	Telemetry Pull-Box Assembly Detail (Special Districts)
MVLI-542B-0	Telemetry Pull-Box Assembly Detail (Parks & CS)
MVLI-543A-0	Master Valve Assembly Detail (Special Districts)
MVLI-543B-0	Master Valve Assembly Detail (Parks & CS)
MVLI-543C-0	Master Valve and Flow Meter Installation (Parks & CS)
MVLI-544A-0	Toe Nipple Assembly (Special Districts)
MVLI-544B-0	Toe Nipple Assembly (Parks & CS)
MVLI-545A-0	Irrigation Wire Connector (Special Districts)
MVLI-545B-0	Irrigation Wire Connector (Parks & CS)
MVLI-545C-0	Irrigation Control Wire Notes (Parks & CS)
MVLI-546-0	Irrigation Booster Pump Detail (Special Districts)
MVLI-547A-0	Reduced Pressure Backflow Preventer (Special Districts)
MVLI-547B-1	Backflow Preventer (Parks and CS)
MVLI-548A-0	Backflow Preventer Enclosure (Special Districts)
MVLI-548B-0	Single Backflow Cover (Parks and CS)
MVLI-548C-0	Double Backflow Cover (Parks and CS)
MVLI-550A-0	Pressure Reducing Valve (Special Districts)
MVLI-550B-0	Pressure Reducing Valve (Parks & CS)
MVLI-551A-0	Ball Valve/Gate Valve - 3" Or Smaller (Special Districts)
MVLI-551B-0	Ball Valve/Gate Valve - 3" Or Smaller (Parks & CS)
MVLI-552A-0	Remote Control Valve with Union (Special Districts)
MVLI-552B-0	Remote Control Valve Detail (Parks and CS)
MVLI-553A-0	Remote Control Valve for Drip Systems (Special Districts)
MVLI-553B-0	Remote Control Valve Detail for Drip Systems (Parks & CS)
MVLI-554A-0	Quick Coupling Valve (Special Districts)
MVLI-554B-0	Quick Coupling Ball Valve (Parks & CS)
MVLI-555A-0	Air Vacuum Relief Valve (Special Districts)
MVLI-555B-0	Air Vacuum Relief Valve (Parks & CS)

City of Moreno Valley

Standard Plans Index - 2017 Edition (with Updates November 2019)

SECTION 5: Landscaping and Irrigation Systems (Continued)

MVLI-556A-0	<i>Irrigation Stub-Out Box (Special Districts)</i>
MVLI-556B-0	<i>Irrigation Stub-Out Box (Parks & CS)</i>
MVLI-560A-0	<i>Landscape Trench Detail (Special Districts)</i>
MVLI-560B-0	<i>Trench Detail (Parks & CS)</i>
MVLI-561A-0	<i>Sleeving Detail (Special Districts)</i>
MVLI-561B-0	<i>Sleeving Detail (Parks & CS)</i>
MVLI-562-0	<i>Median and Parkway Irrigation Line Installation (Special Districts)</i>
MVLI-563A-0	<i>Deep Well Tree Irrigation (Special Districts)</i>
MVLI-563B-0	<i>Deep Well Tree Irrigation (Parks & CS)</i>
MVLI-564-0	<i>Drip Emitter Installation (Special Districts)</i>
MVLI-565-0	<i>Tree Well Sump (Parks & CS)</i>
MVLI-566-0	<i>Rainbird RWS-BCG02 Root Watering System (Parks & CS)</i>
MVLI-570A-0	<i>6" Pop-up Spray Head (Special Districts)</i>
MVLI-570B-0	<i>12" Pop-up Spray Head (Special Districts)</i>
MVLI-570C-0	<i>6" or 12" Pop-up Spray Head (Parks & CS)</i>
MVLI-571A-0	<i>Pop-up Rotary Head (Special Districts)</i>
MVLI-571B-0	<i>Pop-up Rotary Head (Parks & CS)</i>
MVLI-572-0	<i>Rotor Installation on Fixed Riser (Special Districts)</i>
MVLI-573-0	<i>Rainbird 1800 Sam PRS Pop Up Spray Head (Parks & CS)</i>
MVLI-574A-0	<i>Dripperline (With Integrated Check Valves) Center Feed Layout (Special Districts)</i>
MVLI-574B-0	<i>Dripperline (With Integrated Check Valves) Center Feed Layout (Parks & CS)</i>
MVLI-574C-0	<i>Dripperline (Recycled Water Systems) Center Feed Layout (Special Districts)</i>
MVLI-574D-0	<i>Dripperline (Recycled Water Systems) Center Feed Layout (Parks & CS)</i>
MVLI-574E-0	<i>PVC Pipe with Swing-Joint Connection to Dripperline (Special Districts)</i>
MVLI-574F-0	<i>PVC Pipe with Swing-Joint Connection to Dripperline (Parks & CS)</i>
MVLI-574G-0	<i>Manual Shut-Off / Flush Valve (For Dripperline) (Special Districts)</i>
MVLI-574H-1	<i>Manual Shut-Off / Flush Valve (For Dripperline) (Parks & CS)</i>
MVLI-574I-0	<i>Automatic Flush Valve (For Dripperline) (Special Districts)</i>
MVLI-574J-0	<i>Automatic Flush Valve (For Dripperline) (Parks & CS)</i>
MVLI-574K-0	<i>Air / Vacuum Relief Valve (For Dripperline) (Special Districts)</i>
MVLI-574L-1	<i>Air / Vacuum Relief Valve (For Dripperline) (Parks & CS)</i>
MVLI-580A-0	<i>Thrust Blocks (Special Districts)</i>
MVLI-580B-0	<i>Thrust Blocks (Parks & CS)</i>
MVLI-581-0	<i>Box Identification (Parks & CS)</i>
MVLI-582-0	<i>Christy Tag (Parks & CS)</i>

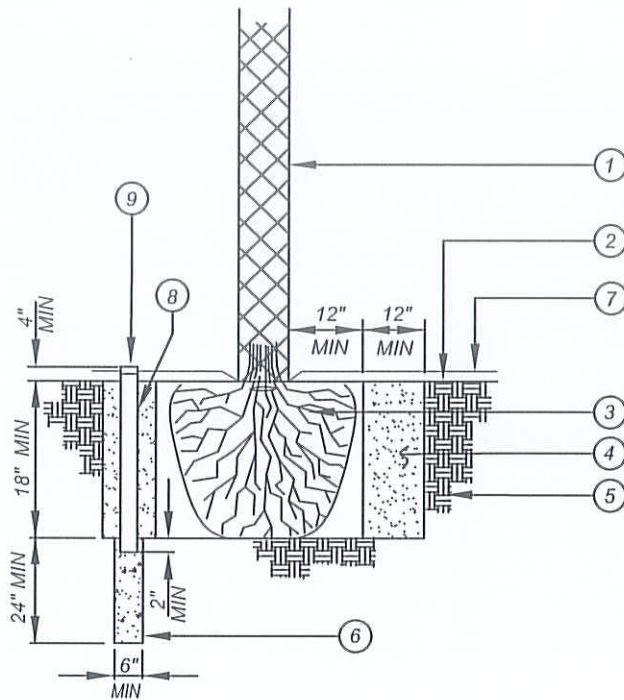



LEGEND:

- ① PALM TRUNK (TRIMMED)
- ② FINISH GRADE
- ③ PALM ROOT BALL (TRIMMED)
- ④ BACKFILL MIX PER SPECIFICATION
- ⑤ NATIVE SOIL
- ⑥ 6" x 24" SUMP - FILL WITH 3/4" MINUS WASHED, WELL-GRADED AGGREGATE
- ⑦ SHREDDED MULCH IN PLANTER BED
- ⑧ 4" PERFORATED POLY PIPE INSPECTION TUBE - COVER WITH FILTER SOCK
- ⑨ 4" POLY PIPE CAP (SLIP) - SECURE WITH TWO (2) SELF-TAPPING SHEET METAL SCREWS

NOTES:

- 1.) ALL PALMS SHALL BE TRIMMED & TIED PRIOR TO PLANTING, LEAVE TIED 14 DAYS MIN.
- 2.) TRIMMED PALM TO HAVE 6-8 FRONDS, OR PER CERTIFIED ARBORIST/PALM SPECIALIST.
- 3.) UPON INSTALLATION REPRESENTATIVES OF THE CITY, THE LANDSCAPE ARCHITECT, AND THE LANDSCAPE CONTRACTOR SHALL DETERMINE IF PALMS REQUIRE GUYING.

NOT TO SCALE

	RECOMMENDED: <i>105</i> <i>1-10-14</i> DIVISION MANAGER DATE	CITY OF MORENO VALLEY FINANCIAL & MANAGEMENT SERVICES DEPARTMENT - SPECIAL DISTRICTS DIVISION PALM TREE PLANTING	STANDARD PLAN MVLI-500A-0
	APPROVED:  PUBLIC WORKS DIRECTOR / DATE CITY ENGINEER		SHEET 1 OF 2

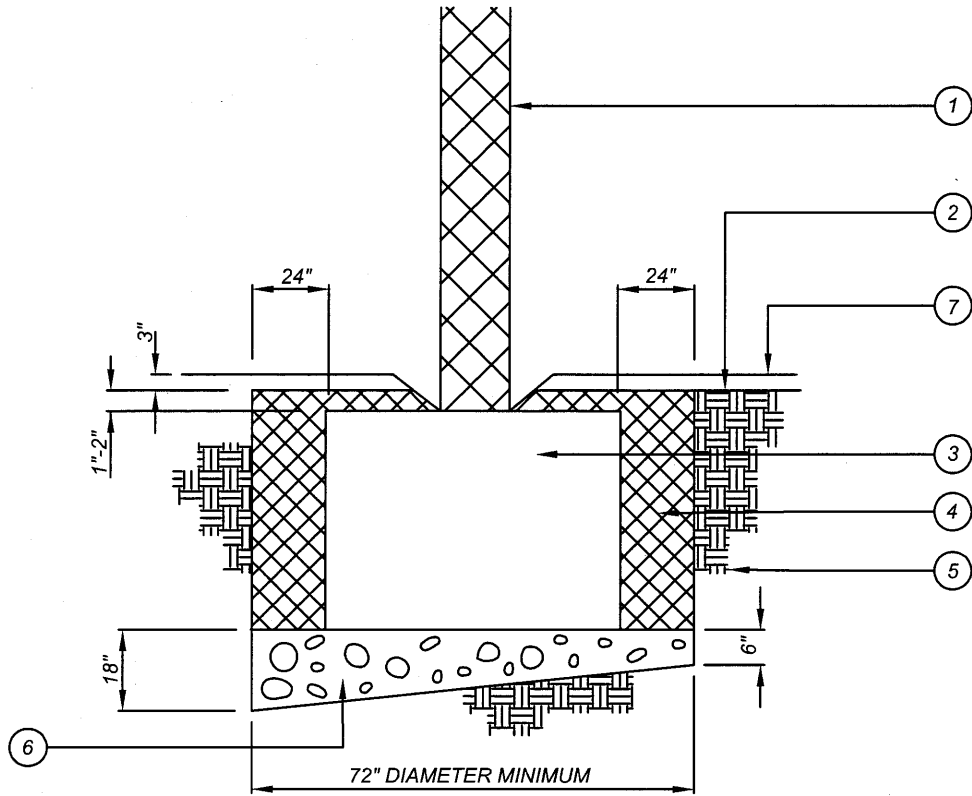





LEGEND:

- ① PALM TRUNK (SKINNED)
- ② FINISH GRADE
- ③ PALM ROOT BALL (TRIMMED)
- ④ WASHED PLASTER SAND BACKFILL
- ⑤ NATIVE SOIL
- ⑥ 3/4" WASHED CRUSHED AGGREGATE
- ⑦ 3" BARK OR DECOMPOSED GRANITE IN PLANTER BED

NOTES:

- 1.) ALL PALMS SHALL BE SKINNED & TIED PRIOR TO PLANTING, LEAVE TIED 90 DAYS MIN.
- 2.) SKINNED PALM TO HAVE 6-8 FRONDS OR PER CERTIFIED ARBORIST/PALM SPECIALIST.
- 3.) UPON INSTALLATION REPRESENTATIVES OF PARKS AND COMMUNITY SERVICES, LANDSCAPE ARCHITECT, LANDSCAPE CONTRACTOR SHALL DETERMINE IF PALMS REQUIRE GUYING.
- 4.) IRRIGATION PER PARKS & COMMUNITY SERVICES STANDARDS.
- 5.) CERTIFICATION OF GENUS AND SPECIES FOR ALL PALMS IS REQUIRED.

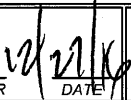
NOT TO SCALE

	RECOMMENDED: 	<h2 style="margin: 0;">CITY OF MORENO VALLEY</h2> <p style="margin: 0;">PARKS AND COMMUNITY SERVICES DEPARTMENT</p>	STANDARD PLAN MVLI-500B-1
	DIVISION MANAGER DATE 	<h3 style="margin: 0;">PALM TREE PLANTING</h3>	SHEET 2 OF 2
APPROVED: 	PUBLIC WORKS DIRECTOR / DATE CITY ENGINEER		

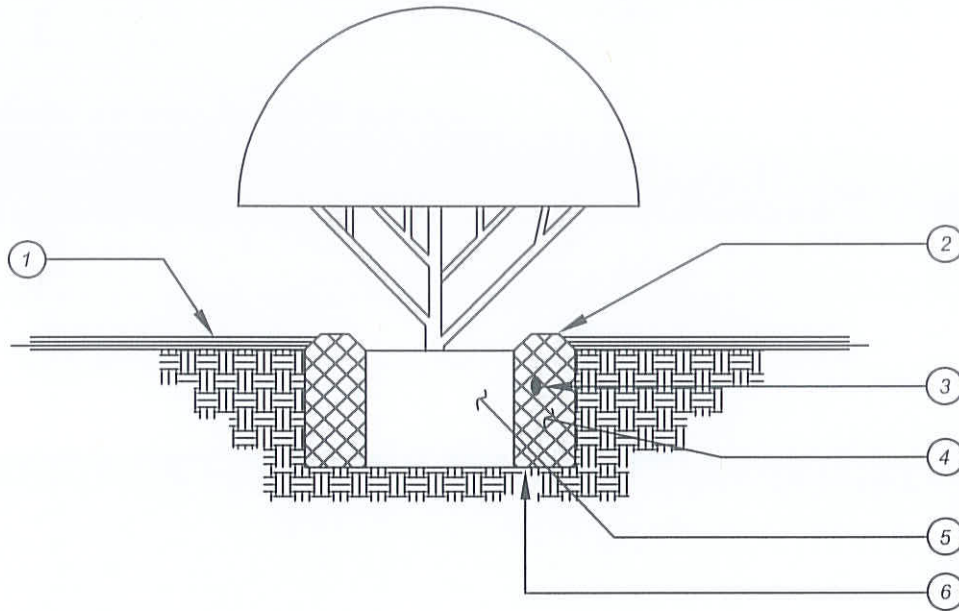



LEGEND:

- ① 3" THICK (MINIMUM) SHREDDED MULCH (PER PLAN AS SPECIFIED).
- ② 4" BERM TO FORM WATERING BASIN (BERM TO BE REMOVED PRIOR TO MULCH APPLICATION PER THE DISCRETION OF SPECIAL DISTRICTS).
- ③ PLANT TABS PER MANUFACTURER'S RECOMMENDATIONS.
- ④ BACKFILL MIX PER SPECIFICATIONS.
- ⑤ CONTAINER PLANT ROOT BALL.
- ⑥ PLANT PIT TO BE 2 TIMES THE WIDTH OF THE ROOT BALL & SAME DEPTH AS THE ROOT BALL.

NOTES:

- 1.) UNTANGLE MATTED ROOTS BY LOOSENING ALL ROOTS AT EDGE OF ROOT BALL WITH WATER FROM HOSE. DO NOT CRACK ROOT BALL.

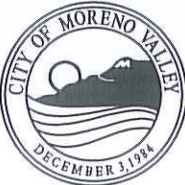
NOT TO SCALE

	RECOMMENDED: <i>COS</i> <i>1-16-14</i> <small>DIVISION MANAGER DATE</small>	<h2 style="margin: 0;">CITY OF MORENO VALLEY</h2> <p style="margin: 0; font-size: small;">FINANCIAL & MANAGEMENT SERVICES DEPARTMENT - SPECIAL DISTRICTS DIVISION</p>	<small>STANDARD PLAN</small> MVLI-501A-0
	APPROVED:  <small>PUBLIC WORKS DIRECTOR/ DATE</small> <small>CITY ENGINEER</small>	<h3 style="margin: 0;">CONTAINER PLANTING</h3>	<small>SHEET 1 OF 4</small>

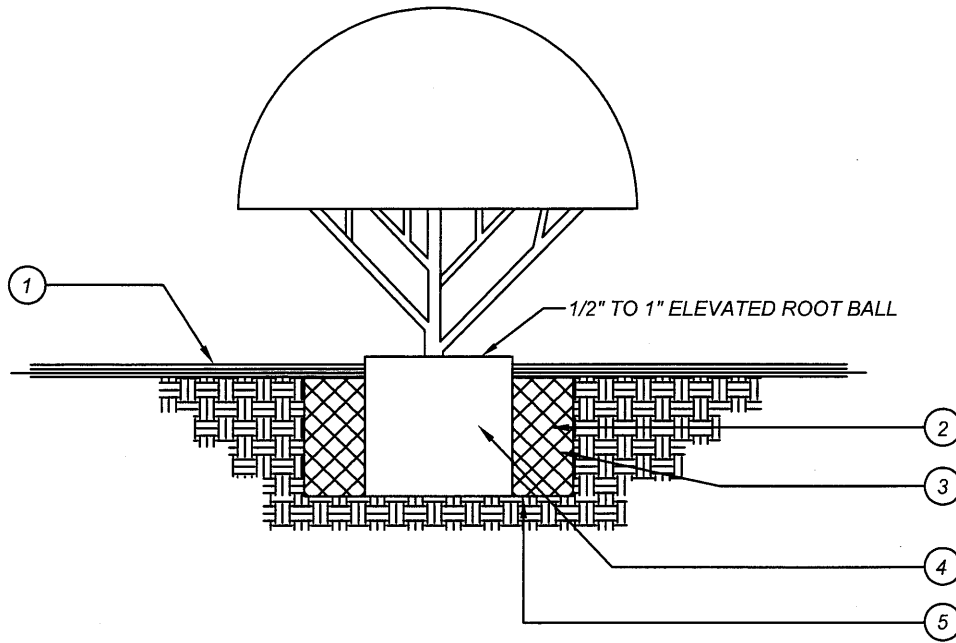

LEGEND:

- ① 3" THICK BARK OR DECOMPOSED GRANITE PER SPECIFICATIONS
- ② PLANT TABS PER MANUFACTURER'S RECOMMENDATIONS.
- ③ BACKFILL MIX PER SPECIFICATIONS.
- ④ CONTAINER PLANT ROOT BALL.
- ⑤ PLANT PIT TO BE 2 TIMES THE WIDTH OF THE ROOT BALL & SAME DEPTH AS THE ROOT BALL.

NOTES:

1.) UNTANGLE MATTED ROOTS BY LOOSENING ALL ROOTS AT EDGE OF ROOT BALL WITH WATER FROM HOSE. DO NOT CRACK ROOT BALL.

NOT TO SCALE

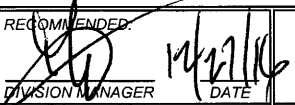
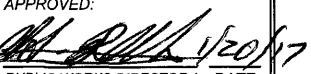
	RECOMMENDED:  DIVISION MANAGER DATE	<h2 style="margin: 0;">CITY OF MORENO VALLEY</h2> <p style="margin: 0;">PARKS AND COMMUNITY SERVICES DEPARTMENT</p>	STANDARD PLAN <h3 style="margin: 0;">MVLI-501B-1</h3>
	APPROVED:  PUBLIC WORKS DIRECTOR / DATE CITY ENGINEER	<h3 style="margin: 0;">CONTAINER PLANTING (SHRUB BEDS)</h3>	SHEET 2 OF 4

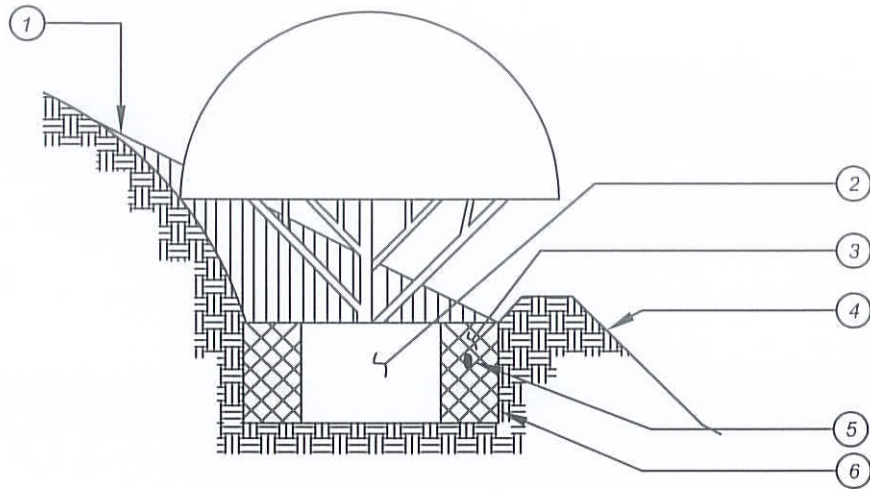

LEGEND:

- ① ORIGINAL GRADE.
- ② CONTAINER PLANT ROOT BALL.
- ③ BACKFILL MIX PER SPECIFICATIONS.
- ④ 4" BERM TIGHTLY COMPACTED IN PLACE TO FORM WATERING BASIN.
- ⑤ PLANT TABS PER MANUFACTURER'S RECOMMENDATIONS.
- ⑥ PLANTING PIT TO BE 2 TIMES THE WIDTH OF THE ROOT BALL & SAME DEPTH AS THE ROOT BALL.

NOT TO SCALE

	RECOMMENDED: <i>CO5</i> <i>1-16-14</i> <small>DIVISION MANAGER DATE</small>	CITY OF MORENO VALLEY FINANCIAL & MANAGEMENT SERVICES DEPARTMENT - SPECIAL DISTRICTS DIVISION	<small>STANDARD PLAN</small> MVLI-501C-0
	APPROVED: <small>PUBLIC WORKS DIRECTOR / DATE</small> <i>1/29/14</i> <small>CITY ENGINEER</small>	CONTAINER PLANTING ON SLOPE	<small>SHEET 3 OF 4</small>

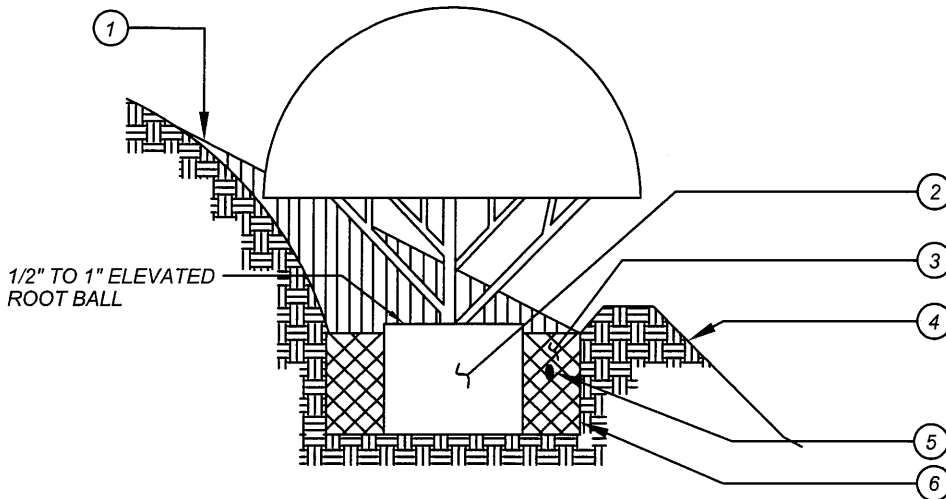



LEGEND:

- ① ORIGINAL GRADE.
- ② CONTAINER PLANT ROOT BALL.
- ③ BACKFILL MIX PER SPECIFICATIONS.
- ④ 4" BERM TIGHTLY COMPACTED IN PLACE TO FORM WATERING BASIN.
- ⑤ PLANT TABS PER MANUFACTURER'S RECOMMENDATIONS.
- ⑥ PLANTING PIT TO BE 2 TIMES THE WIDTH OF THE ROOT BALL & SAME DEPTH AS THE ROOT BALL.

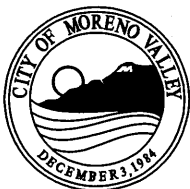
NOT TO SCALE

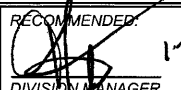

RECOMMENDED:

 DIVISION MANAGER DATE 12/27/16

APPROVED:

 PUBLIC WORKS DIRECTOR / DATE 1/20/17
 CITY ENGINEER

CITY OF MORENO VALLEY

PARKS AND COMMUNITY SERVICES DEPARTMENT

**CONTAINER PLANTING
ON SLOPE**

STANDARD PLAN

MVLI-501D-1

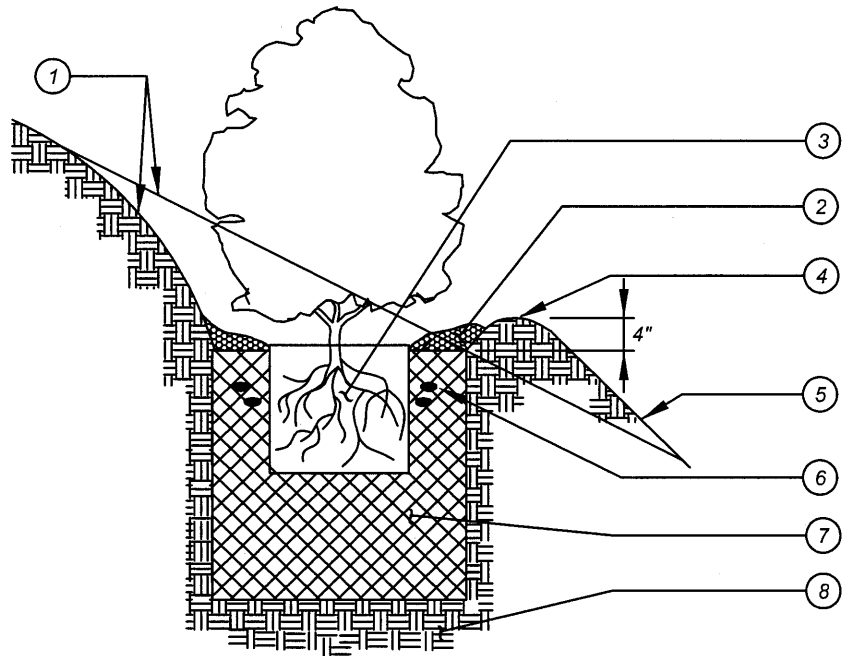
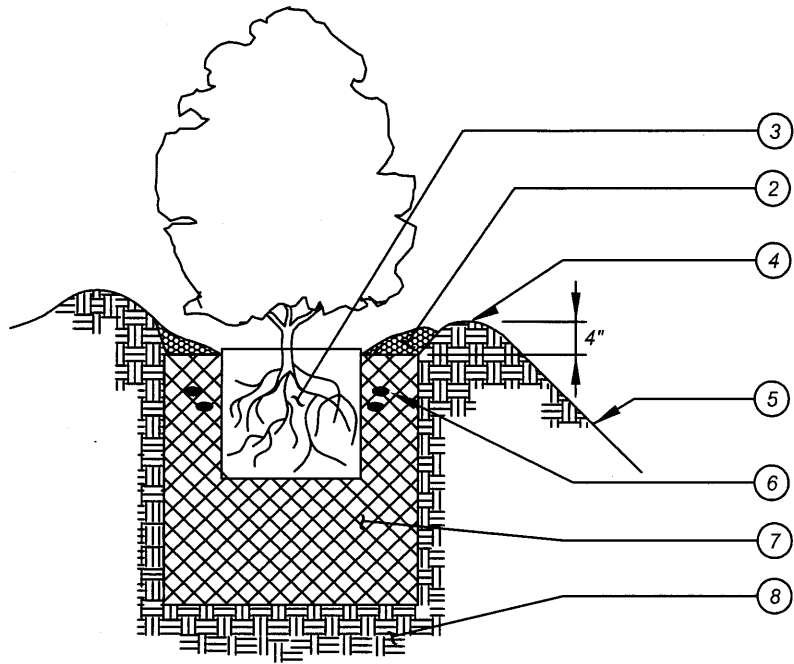

SHEET 4 OF 4



LEGEND:

- ① ORIGINAL SLOPE AND CUT SLOPE FOR BASIN
- ② 2" THICK BARK OR DG PER LANDSCAPE SPECIFICATIONS
- ③ ROOTBALL (SET CROWN 1" ABOVE FINISH GRADE TYPICAL)
- ④ COMPACTED WATERING BASIN
- ⑤ FINISH GRADE
- ⑥ ADD TRI-C MYCORRHIZAE PACKS TO EACH PLANT BASIN
- ⑦ COMPACTED BACKFILL MIX (PER NATIVE PLANTING SPECS.) 2x ROOTBALL WIDTH, 2x ROOTBALL DEPTH
- ⑧ UNDISTURBED NATIVE SOIL

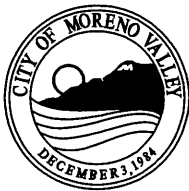
NOT TO SCALE

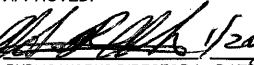
	RECOMMENDED:  DIVISION MANAGER	12/27/16 DATE	<h2 style="margin: 0;">CITY OF MORENO VALLEY</h2> <p style="margin: 0;">PARKS AND COMMUNITY SERVICES DEPARTMENT</p>	STANDARD PLAN MVLI-502-1
	APPROVED:  PUBLIC WORKS DIRECTOR / DATE	1/20/17 CITY ENGINEER	<h3 style="margin: 0;">NATIVE SHRUB PLANTING/ ON SLOPE SHRUB PLANTING</h3>	

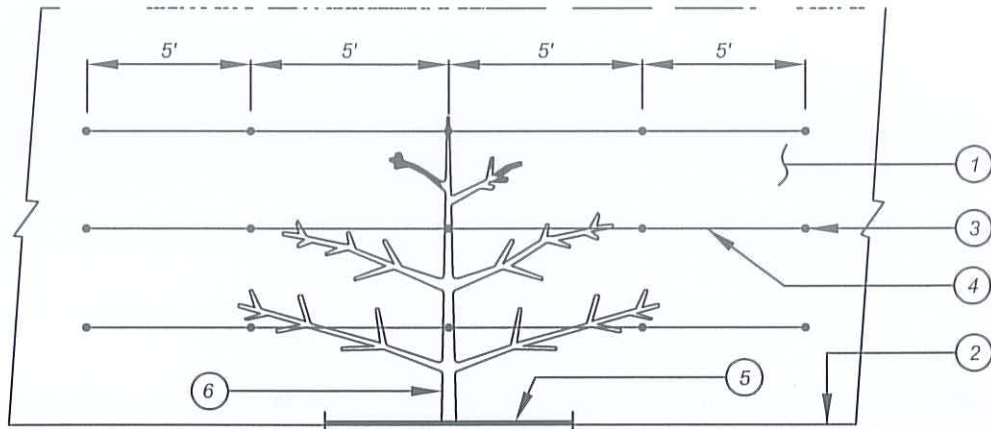

ELEVATION

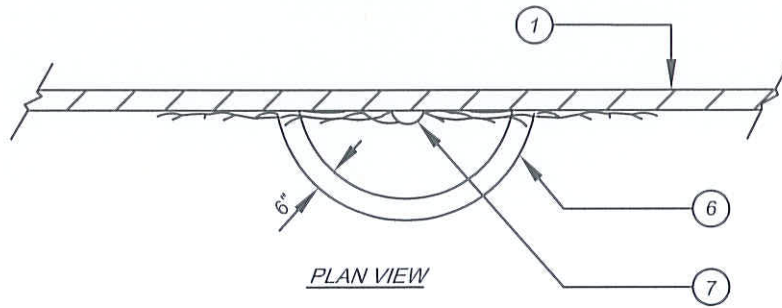

PLAN VIEW

LEGEND:

- ① WALL
- ② FINISH GRADE
- ③ EYEBOLTS: 1/2" DIA EYEBOLTS IN LEAD SHIELDS
- ④ 12 GA. GALV. WIRE: SECURE VINE TO WIRE WITH NURSERYMAN'S TAPE
- ⑤ 6" x 8" CONCRETE VINE COLLARS IN TURF AREAS ONLY. INSIDE RADIUS OF COLLAR TO BE TWO TIMES THE DIAMETER OF ROOTBALL MINIMUM
- ⑥ VINE (PER PLAN AS SPECIFIED)

NOTE:

- 1.) ANGLE TRUNK OF VINE VINE BACK TO WALL, REMOVE NURSERY STAKE, AND SECURE VINE TO WIRES WITH NURSERYMAN'S TAPE.

NOT TO SCALE



RECOMMENDED:
 DIVISION MANAGER DATE
 APPROVED:
 PUBLIC WORKS DIRECTOR / DATE
 CITY ENGINEER

CITY OF MORENO VALLEY
 FINANCIAL & MANAGEMENT SERVICES DEPARTMENT - SPECIAL DISTRICTS DIVISION

VINE DETAIL
NON - ADHERING TYPE

STANDARD PLAN
MVLI-503A-0
 SHEET 1 OF 2

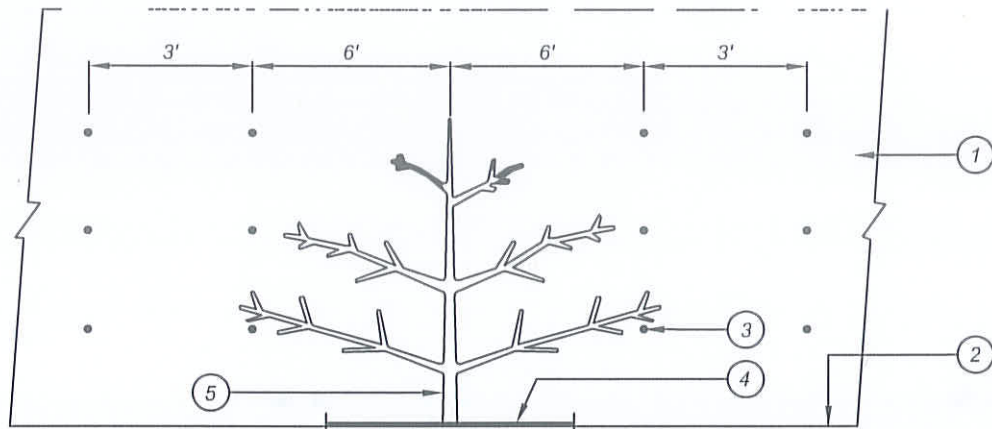

ELEVATION

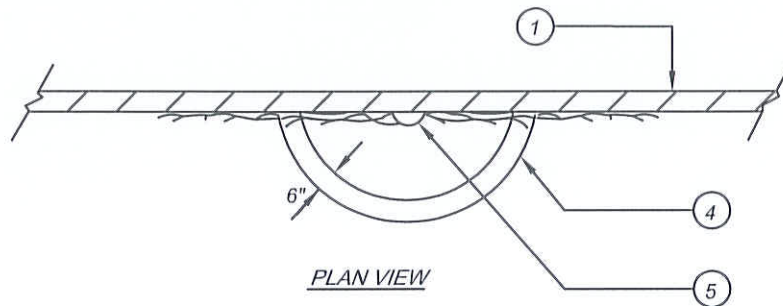

PLAN VIEW

LEGEND:

- ① WALL
- ② FINISH GRADE
- ③ ADHESIVE VINE SUPPORTS
- ④ 6" x 8" CONCRETE VINE COLLARS IN TURF AREAS ONLY. INSIDE RADIUS OF COLLAR TO BE TWO TIMES THE DIAMETER OF ROOTBALL MINIMUM (#4 REBAR REQUIRED)
- ⑤ ANGLE BACK TO WALL TRUNK OF VINE, AND REMOVE STAKE WHILE SECURING VINE TO SUPPORTS

NOT TO SCALE

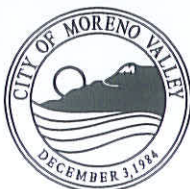

RECOMMENDED:
 1/21/14
 DIVISION MANAGER DATE

APPROVED:
 1/29/14
 PUBLIC WORKS DIRECTOR / DATE
 CITY ENGINEER

CITY OF MORENO VALLEY

PARKS AND COMMUNITY SERVICES DEPARTMENT

**VINE DETAIL
 ADHERING TYPE**

STANDARD PLAN
MVLI-503B-0

SHEET 2 OF 2

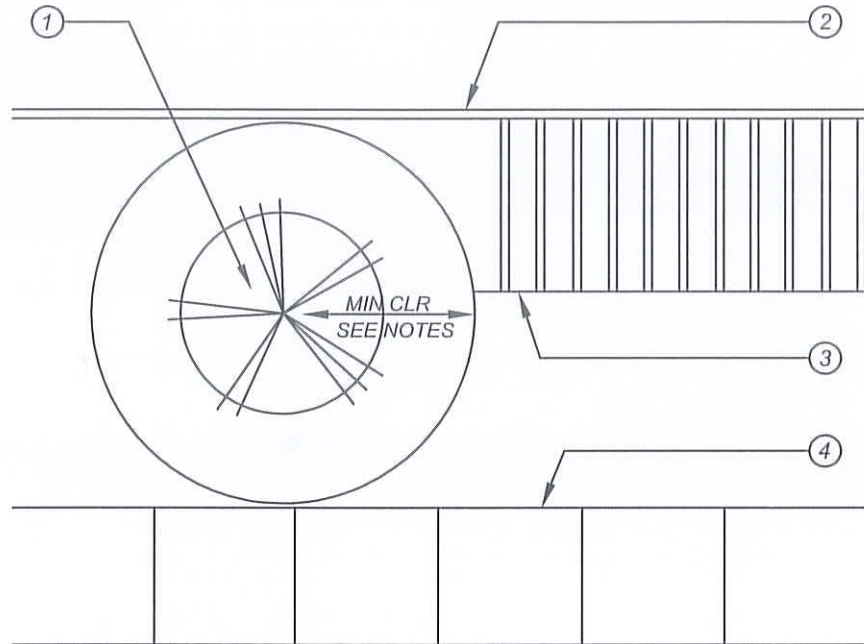

LEGEND:

- ① PROPOSED CENTER OF TREE
- ② STRUCTURE /WALL/ETC.
- ③ AWNING/BUILDING OVERHANG
- ④ HARDSCAPING

NOTES:

- 1) MINIMUM CLEARANCE: 5'-0" FOR 5 GALLON TO 24" BOX TREES, LARGER TREES PER CITY APPROVAL 10' MINIMUM CLEARANCE FROM STREET LIGHTS - ALL TREES.
- 2) IN CASES WHERE TREE TRUNKS ARE 5'-0" OR LESS FROM WALLS AND HARDSCAPING, INSTALL TREE WITH ROOT BARRIERS (REFER TO STD MVLI-504-0).
- 3) TREE SPACING SHALL BE APPROVED ON PLAN BY THE CITY BEFORE ANY SCHEDULED INSTALLATION.
- 4) STREET TREE PLANS SHALL INCLUDE ALL VERTICAL UTILITIES ON PLANTING PLAN.

NOT TO SCALE

	RECOMMENDED: <i>cos</i> <i>1-16-14</i> DIVISION MANAGER DATE	CITY OF MORENO VALLEY FINANCIAL & MANAGEMENT SERVICES DEPARTMENT - SPECIAL DISTRICTS DIVISION	STANDARD PLAN MVLI-504-0
	APPROVED: <i>1/29/14</i> PUBLIC WORKS DIRECTOR / DATE CITY ENGINEER	TREE SPACING REQUIREMENTS	

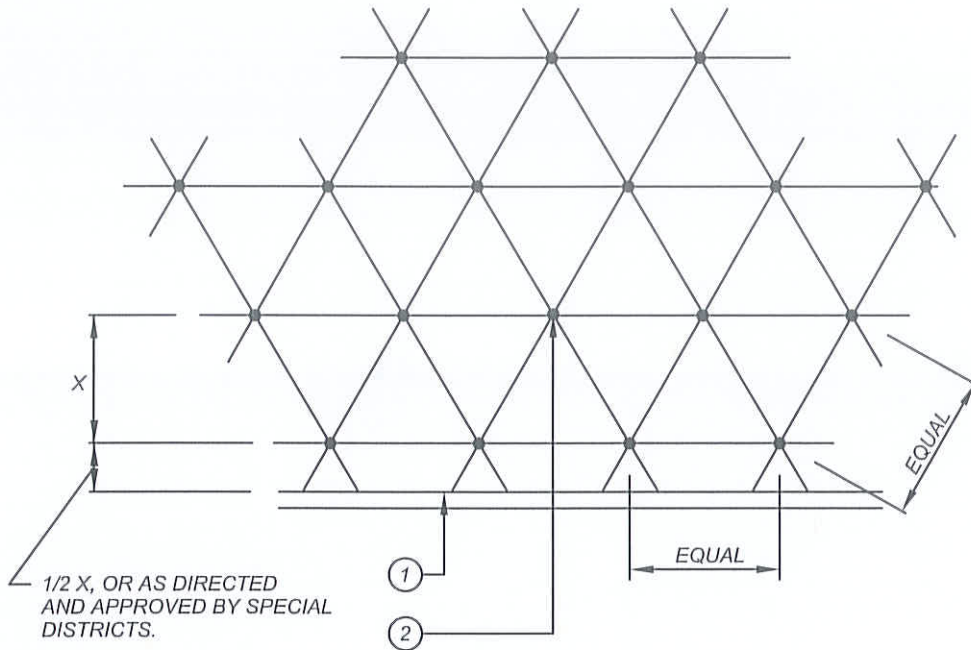

LEGEND:

- ① BACK OF CURB OR EDGE OF PAVING
- ② PLANT LOCATION

NOTES:

1.) ALL SHRUBS / GROUND COVER TO BE PLANTED AT EQUAL SPACING (TRIANGULAR) UNLESS OTHERWISE INDICATED ON PLANS: SEE LEGEND FOR SPACING REQUIREMENTS.

NOT TO SCALE

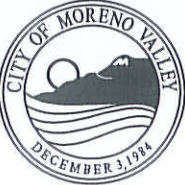
	RECOMMENDED: <div style="display: flex; justify-content: space-between;"> <i>COS</i> <i>1-16-14</i> </div> <small>DIVISION MANAGER DATE</small>	<h2 style="margin: 0;">CITY OF MORENO VALLEY</h2> <p style="margin: 0; font-weight: normal;">FINANCIAL & MANAGEMENT SERVICES DEPARTMENT - SPECIAL DISTRICTS DIVISION</p>	
	APPROVED: <div style="display: flex; justify-content: space-between;"> <i>[Signature]</i> <i>1/29/14</i> </div> <small>PUBLIC WORKS DIRECTOR / DATE</small> <small>CITY ENGINEER</small>	<h3 style="margin: 0;">SHRUB / GROUND COVER SPACING</h3>	

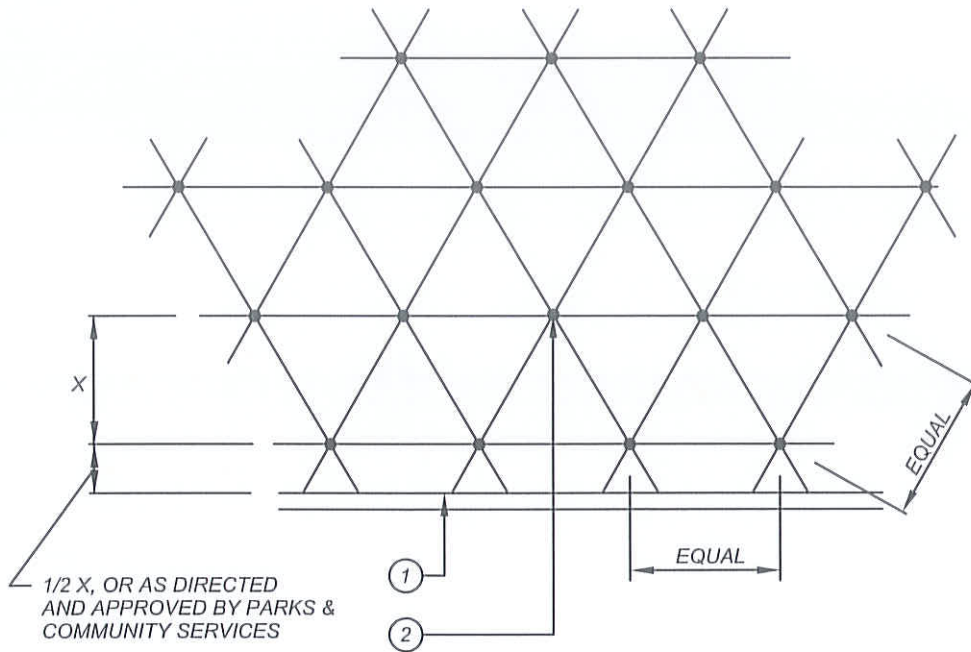



LEGEND:

- ① BACK OF CURB OR EDGE OF PAVING
- ② PLANT LOCATION

NOTES:

1.) ALL SHRUBS / GROUND COVER TO BE PLANTED AT EQUAL SPACING (TRIANGULAR) UNLESS OTHERWISE INDICATED ON PLANS: SEE LEGEND FOR SPACING REQUIREMENTS.

NOT TO SCALE

	RECOMMENDED:  1/21/14 DIVISION MANAGER / DATE	CITY OF MORENO VALLEY PARKS AND COMMUNITY SERVICES DEPARTMENT	
	APPROVED:  1/29/14 PUBLIC WORKS DIRECTOR / DATE CITY ENGINEER	SHRUB / GROUNDCOVER SPACING	

WIRE SIZE LEGEND	
BOX SIZE	WIRE SIZE
24"	#14
36"	#12
42" & OVER	#10

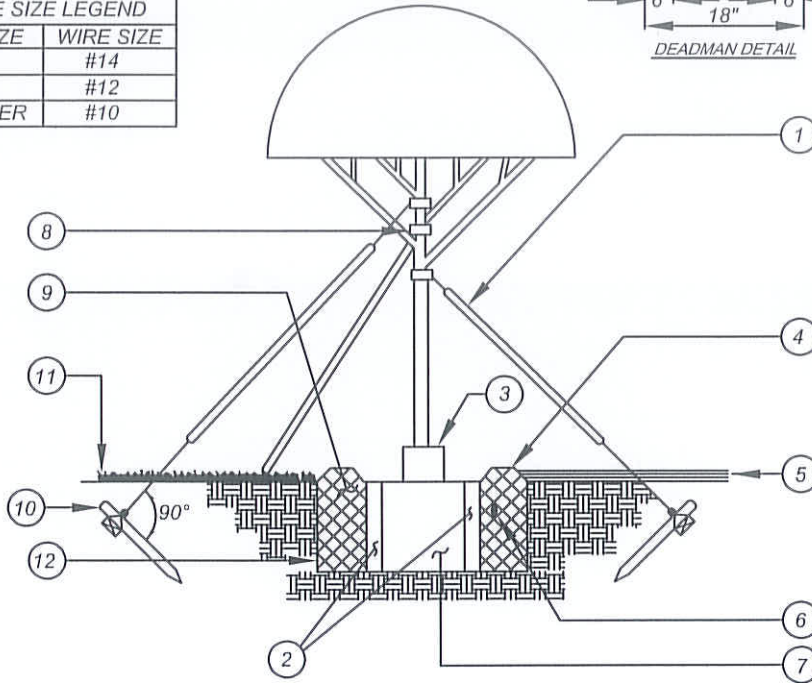
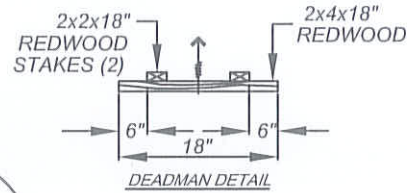

LEGEND:

- ① (3) DOUBLE STRAND GALV. 12 GA. WIRE GUYS SPACED EQUALLY AROUND TREE - COVER WITH 3/8" DIA x3" WHITE PVC TUBING
- ② REFER TO STANDARD MVLI-563-0 FOR IRRIGATION METHOD
- ③ USE TRUNK GUARD WHERE TREE IS INSTALLED IN TURF AREAS
- ④ 4" BERM TO FORM DEPRESSED WATERING BASIN
- ⑤ 3" THICK SHREDDED MULCH IN PLANTER
- ⑥ PLANT TABS PER MANUFACTURER'S RECOMMENDATIONS
- ⑦ ROOT BALL
- ⑧ NEW RUBBER HOSE OVER WIRE AT POINT OF CONNECTION
- ⑨ BACKFILL MIX PER SPECIFICATIONS
- ⑩ REDWOOD DEADMAN PER DETAIL THIS SHEET, ALTERNATE METHOD PER CITY EQUIPMENT LIST
- ⑪ TURF
- ⑫ PLANTING PIT TO BE 2 TIMES THE WIDTH OF ROOT BALL & SAME DEPTH AS THE ROOT BALL

NOTES:

- 1) INSTALL GUYS HAND TAUT TO PREVENT DEFORMATION OF LIMBS.
- 2) PLACE FERTILIZER TABS IN BOX PRIOR TO PLANTING FOR OBSERVATION.
- 3) ALTERNATE DEADMAN ASSEMBLY.

NOT TO SCALE

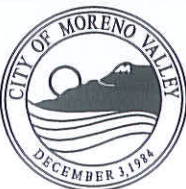

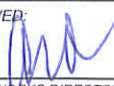
RECOMMENDED:
 1-16-14
 DIVISION MANAGER DATE
 APPROVED:
 1/29/14
 PUBLIC WORKS DIRECTOR / DATE/
 CITY ENGINEER

CITY OF MORENO VALLEY
 FINANCIAL & MANAGEMENT SERVICES DEPARTMENT - SPECIAL DISTRICTS DIVISION

TREE GUYING DETAIL
36" BOX OR LARGER

STANDARD PLAN
MVLI-510A-0

SHEET 1 OF 2

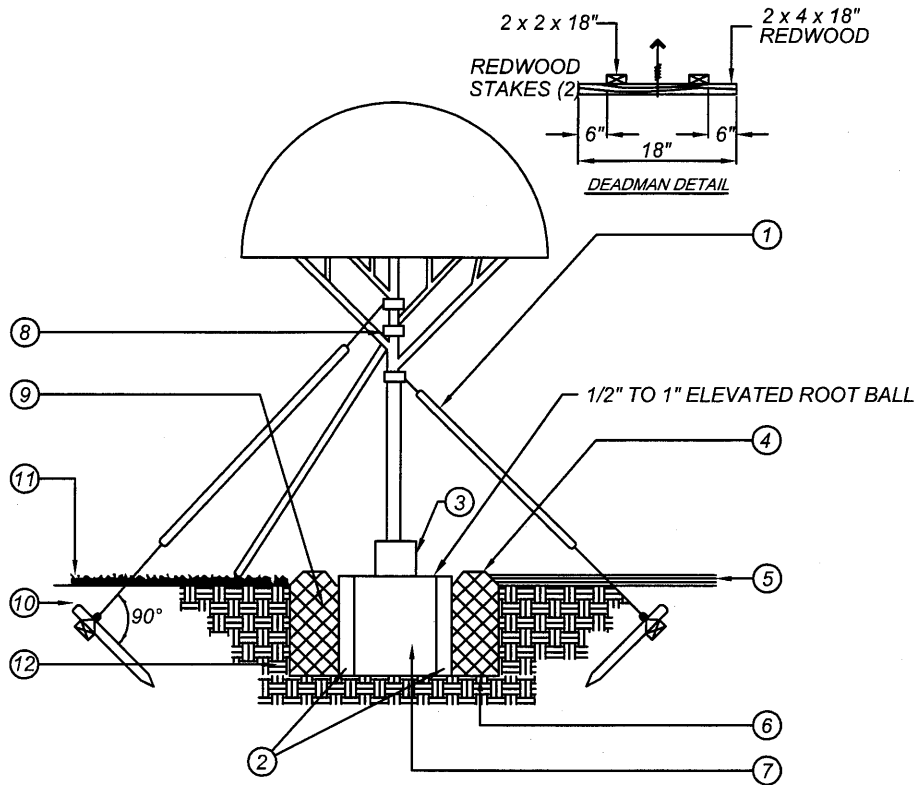

LEGEND:

- ① (3) PVC COATED STRANDED 3/8" CABLE GUYS SPACED EQUALLY AROUND TREE - COVER WITH 3/4" DIA WHITE SCH 40 PVC TUBING
- ② REFER TO PARK SPECIFICATIONS FOR IRRIGATION METHOD
- ③ USE TRUNK GUARD WHERE TREE IS INSTALLED IN TURF AREAS
- ④ 4" BERM TO FORM DEPRESSED WATERING BASIN
- ⑤ 3" THICK BARK IN PLANTER
- ⑥ FERTILIZER PER MANUFACTURER'S RECOMMENDATIONS
- ⑦ ROOT BALL
- ⑧ NEW RUBBER HOSE OVER WIRE AT POINT OF CONNECTION
- ⑨ BACKFILL MIX PER SPECIFICATIONS
- ⑩ DEADMAN PER DETAIL THIS SHEET, ALTERNATE METHOD PER CITY EQUIPMENT LIST
- ⑪ TURF
- ⑫ PLANT PIT TO BE 2 TIMES THE WIDTH OF ROOT BALL & SAME DEPTH AS THE ROOT BALL

NOTES:

- 1) INSTALL GUYS HAND TAUT TO PREVENT DEFORMATION OF LIMBS.
- 2) PLACE FERTILIZER PACKETS IN BOX PRIOR TO PLANTING FOR OBSERVATION.
- 3) ALTERNATE DEADMAN ASSEMBLY.

NOT TO SCALE

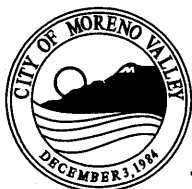

RECOMMENDED:
[Signature] 12/22/16
 DIVISION MANAGER DATE
 APPROVED:
[Signature] 12/20/16
 PUBLIC WORKS DIRECTOR / DATE
 CITY ENGINEER

CITY OF MORENO VALLEY

PARKS AND COMMUNITY SERVICES DEPARTMENT

**TREE GUYING DETAIL
 36" BOX OR LARGER**

STANDARD PLAN
MVLI-510B-1

SHEET 2 OF 2

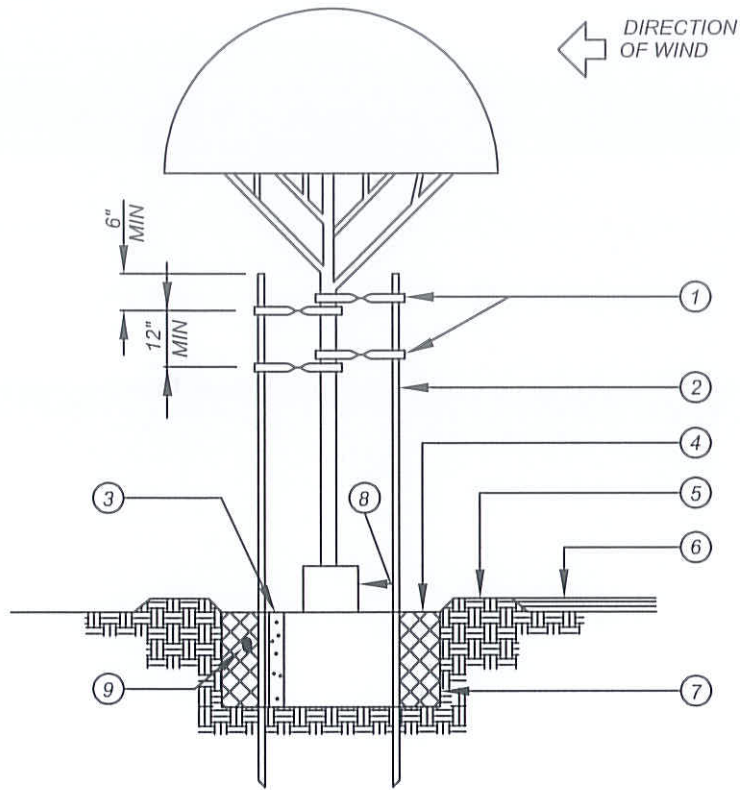



LEGEND:

- ① TREE TIES 4 REQUIRED
- ② 2" LODGEPOLE PINE STAKE
- ③ REFER TO STANDARD MVLI-563-0 FOR IRRIGATION METHOD
- ④ BACKFILL MIX PER SPECIFICATIONS
- ⑤ 4" BERM FOR TEMPORARY WATERING UNTIL SEEDING
- ⑥ 3" THICK SHREDDED MULCH - WHERE APPLICABLE IN PLANTER BEDS
- ⑦ PLANTING PIT: 2 TIMES WIDTH OF ROOT BALL & SAME DEPTH AS ROOT BALL
- ⑧ TRUNK GUARD IN TURF AREAS
- ⑨ PLACE PLANT TABS PER MANUFACTURERS RECOMMENDATION

NOTES:

- 1) INSTALL STAKES 12" MINIMUM FROM TREE TRUNK AND/OR OUTSIDE OF ROOTBALL.

NOT TO SCALE

	RECOMMENDED: <i>COS</i> <i>1-16-14</i> <small>DIVISION MANAGER DATE</small>	<h2 style="margin: 0;">CITY OF MORENO VALLEY</h2> <p style="margin: 0;">FINANCIAL & MANAGEMENT SERVICES DEPARTMENT - SPECIAL DISTRICTS DIVISION</p>	<small>STANDARD PLAN</small> MVLI-511A-0
	APPROVED:  <i>1/29/14</i> <small>PUBLIC WORKS DIRECTOR / DATE</small> <small>CITY ENGINEER</small>	<h3 style="margin: 0;">TYPICAL DOUBLE STAKE TREE</h3> <p style="margin: 0;">(15 GAL. - 24" BOX)</p>	<small>SHEET 1 OF 5</small>

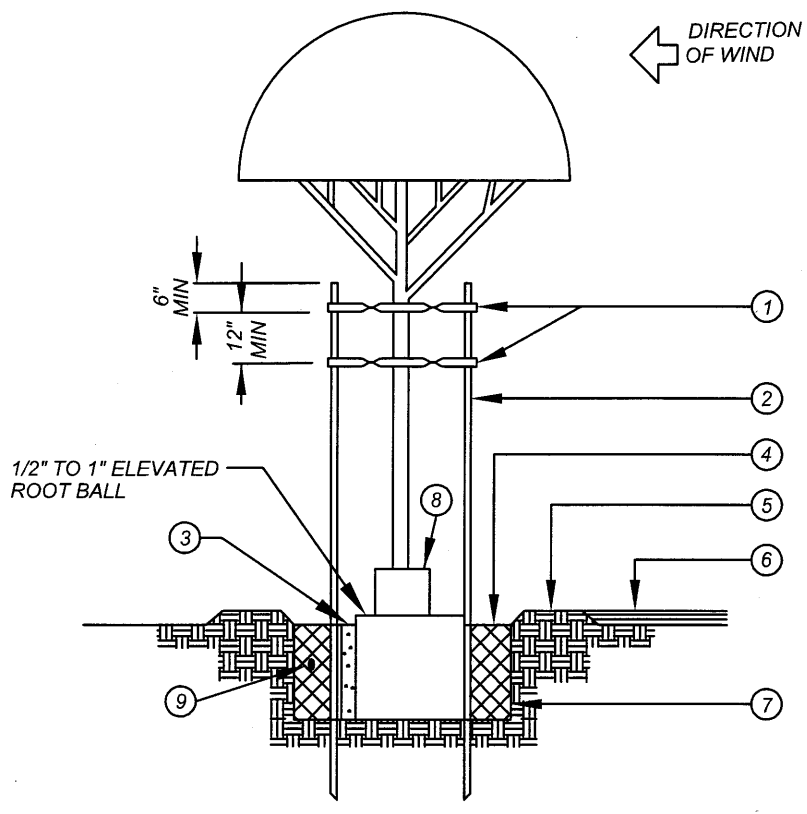

LEGEND:

- ① V.I.T. PLASTIC COATED METAL BRACE 2 REQUIRED
- ② 2" LODGEPOLE PINE STAKE
- ③ RAINBIRD ROOT WATERING SYSTEM (RWS) IRRIGATION (EXCEPT TURF AREAS)
- ④ BACKFILL MIX PER SPECIFICATIONS
- ⑤ 4" BERM FOR TEMPORARY WATERING UNTIL SEEDING/SODDING
- ⑥ 3" THICK BARK - WHERE APPLICABLE
- ⑦ PLANT PIT: 2 TIMES WIDTH OF ROOT BALL & SAME DEPTH AS ROOT BALL
- ⑧ TRUNK GUARD IN TURF AREAS
- ⑨ PLACE FERTILIZER PACKETS PER MANUFACTURER'S RECOMMENDATION

NOTES:

- 1) INSTALL STAKES 12" MINIMUM FROM TREE TRUNK AND/OR OUTSIDE ROOTBALL.

NOT TO SCALE

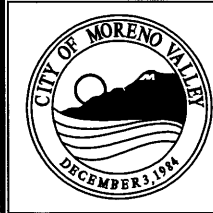

RECOMMENDED:
[Signature] 1/20/16
 DIVISION MANAGER DATE

APPROVED:
[Signature] 1/20/16
 PUBLIC WORKS DIRECTOR / DATE
 CITY ENGINEER

CITY OF MORENO VALLEY
 PARKS AND COMMUNITY SERVICES DEPARTMENT

TYPICAL DOUBLE STAKE TREE

STANDARD PLAN
MVLI-511B-1
 SHEET 2 OF 5

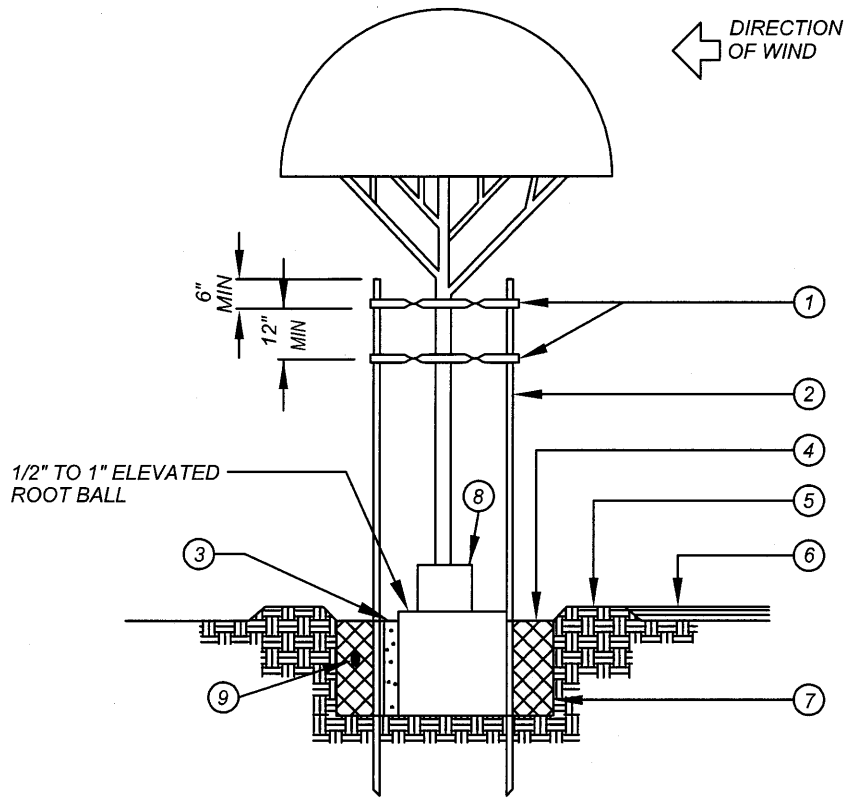



LEGEND:

- ① V.I.T. PLASTIC COATED METAL BRACE 2 REQUIRED BOLT TO PIPE
- ② 2" SCHEDULE 40 GALVANIZED PIPE. DRILL PIPE TO INSTALL TWIST BRACE
- ③ RAINBIRD ROOT WATERING SYSTEM (RWS) IRRIGATION, MINIMUM 2 (EXCEPT TURF AREAS)
- ④ BACKFILL MIX PER SPECIFICATIONS
- ⑤ 4" BERM FOR TEMPORARY WATERING UNTIL SEEDING/SODDING
- ⑥ 3" THICK BARK - WHERE APPLICABLE
- ⑦ PLANT PIT: 2 TIMES WIDTH OF ROOT BALL & SAME DEPTH AS ROOT BALL
- ⑧ TRUNK GUARD IN TURF AREAS
- ⑨ PLACE FERTILIZER PACKETS PER MANUFACTURER'S RECOMMENDATION

NOTES:

- 1) INSTALL STAKES 18" MINIMUM FROM TREE TRUNK AND/OR OUTSIDE ROOTBALL.

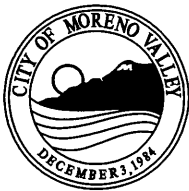
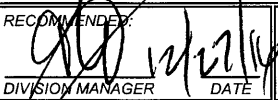
NOT TO SCALE

	RECOMMENDED:  DIVISION MANAGER DATE	CITY OF MORENO VALLEY PARKS AND COMMUNITY SERVICES DEPARTMENT	STANDARD PLAN
	APPROVED:  PUBLIC WORKS DIRECTOR / DATE CITY ENGINEER	STEEL DOUBLE STAKE TREE	MVLI-511C-1 SHEET 3 OF 5

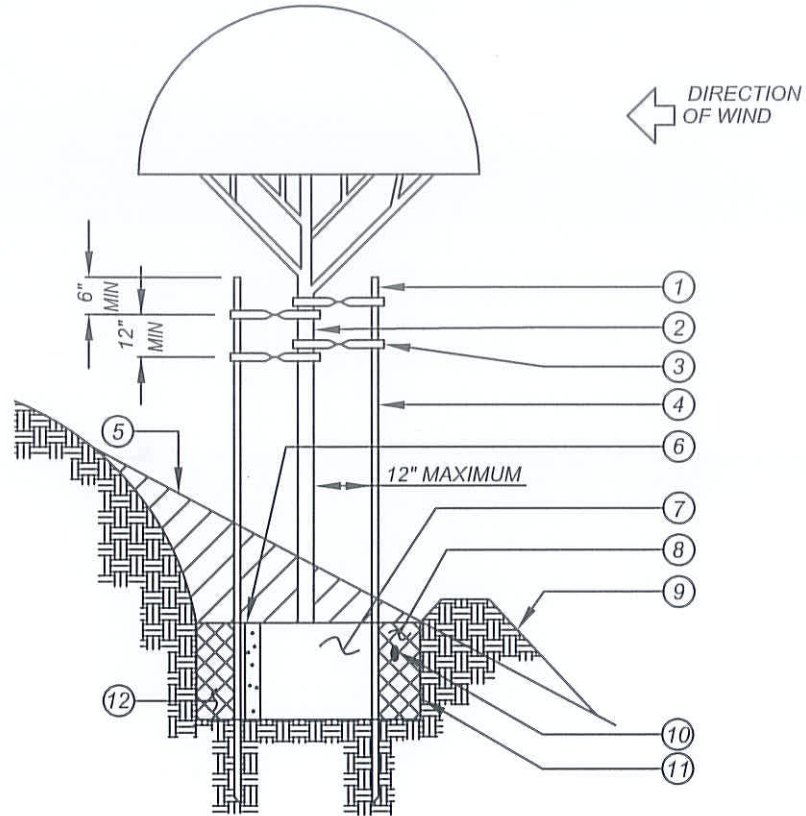

LEGEND:

- ① TOP OF STAKES
- ② MAIN TRUNK
- ③ TREE TIES (4 REQUIRED) 12" APART MIN. NAILED TO STAKES
- ④ APPROVED 10' TREE STAKES (2) PER SPECIFICATIONS
- ⑤ ORIGINAL GRADE
- ⑥ REFER TO STANDARD MVLI-563-0 FOR IRRIGATION METHOD
- ⑦ CONTAINER ROOT BALL
- ⑧ BACKFILL MIX PER SPECIFICATIONS
- ⑨ 4" BERM TIGHTLY COMPACTED IN PLACE TO FORM WATERING BASIN
- ⑩ PLANTING TABS PER MANUFACTURERS RECOMMENDATIONS
- ⑪ PLANTING PIT TO BE 2 TIMES WIDTH OF ROOT BALL & SAME DEPTH AS THE ROOT BALL
- ⑫ NATIVE SOIL BACKFILL (COMPACTED)

NOTES:

1) INSTALL STAKES 12" MINIMUM FROM TREE TRUNK AND/OR OUTSIDE OF ROOTBALL.

NOT TO SCALE



RECOMMENDED:
 COS 1-16-14
 DIVISION MANAGER DATE
 APPROVED:
 [Signature] 1/29/14
 PUBLIC WORKS DIRECTOR DATE
 CITY ENGINEER

CITY OF MORENO VALLEY
 FINANCIAL & MANAGEMENT SERVICES DEPARTMENT - SPECIAL DISTRICTS DIVISION

DOUBLE STAKE TREE ON SLOPE

STANDARD PLAN
MVLI-511D-0

SHEET 4 OF 5

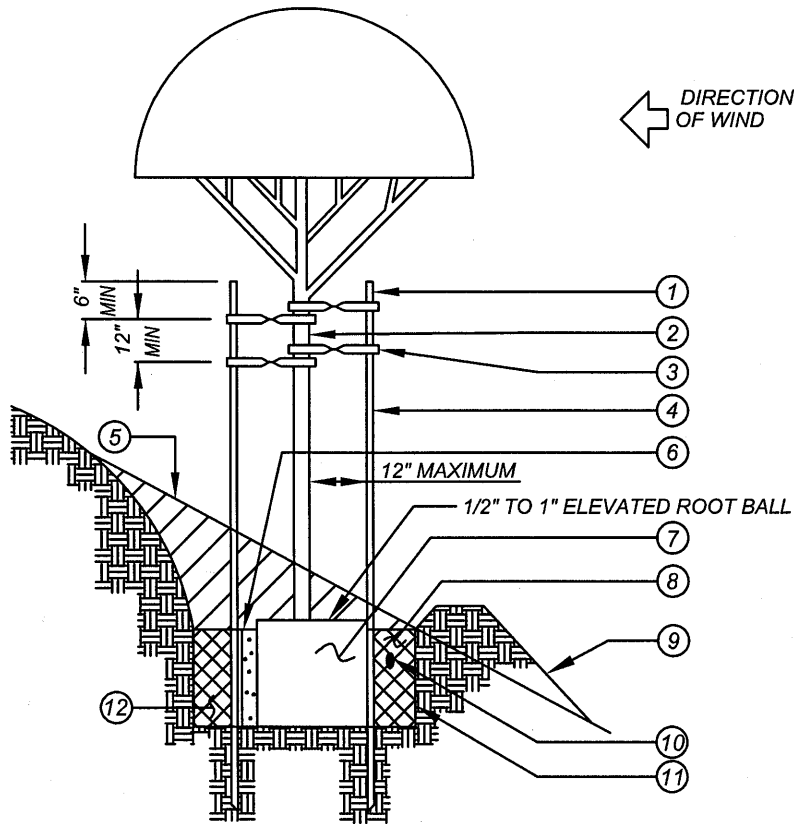



LEGEND:

- ① TOP OF STAKES
- ② MAIN TRUNK
- ③ TREE TIES (4 REQUIRED) 12" APART MIN NAILED TO STAKES
- ④ APPROVED 10' TREE STAKES (2) PER SPECIFICATIONS
- ⑤ ORIGINAL GRADE
- ⑥ REFER TO STANDARD MVLI-563 FOR IRRIGATION METHOD
- ⑦ CONTAINER ROOT BALL
- ⑧ BACKFILL MIX PER SPECIFICATIONS
- ⑨ 4" BERM TIGHTLY COMPACTED IN PLACE TO FORM WATERING BASIN
- ⑩ FERTILIZER PACKETS PER MANUFACTURERS RECOMMENDATIONS
- ⑪ PLANTING PIT TO BE 2 TIMES WIDTH OF ROOT BALL & SAME DEPTH AS THE ROOT BALL
- ⑫ BACKFILL PER SPECIFICATIONS

NOTES:

- 1) INSTALL STAKES 12" MINIMUM FROM TREE TRUNK AND/OR OUTSIDE OF ROOT BALL.

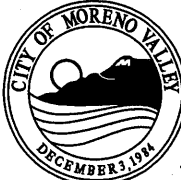
NOT TO SCALE

	RECOMMENDED:  1/24/17 DIVISION MANAGER DATE	<h2 style="margin: 0;">CITY OF MORENO VALLEY</h2> <p style="margin: 0;">PARKS AND COMMUNITY SERVICES DEPARTMENT</p>	STANDARD PLAN
	APPROVED:  1/20/17 PUBLIC WORKS DIRECTOR / DATE CITY ENGINEER	<h3 style="margin: 0;">DOUBLE STAKE TREE ON SLOPE</h3>	

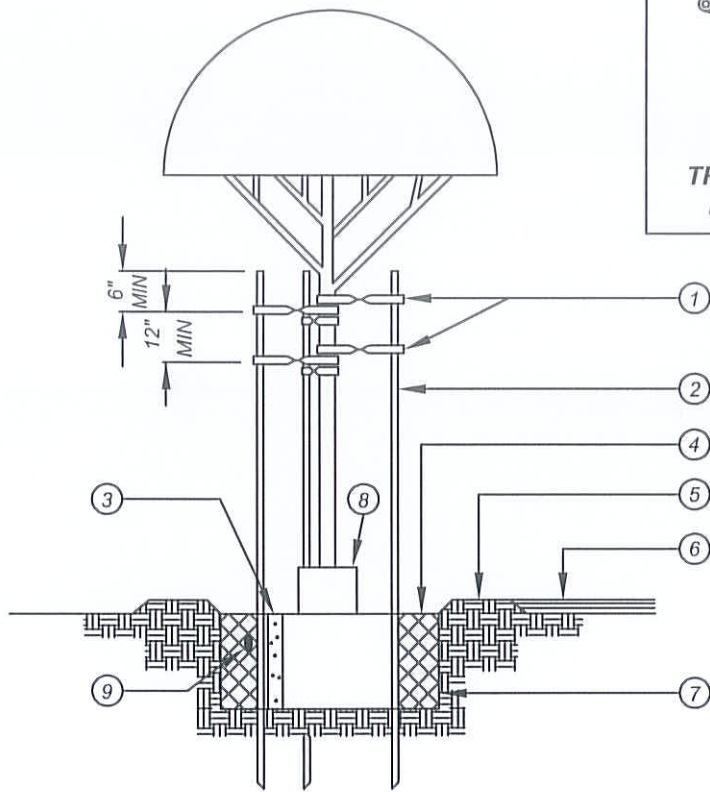

TRIPLE STAKE
PLAN VIEW



LEGEND:

- ① TREE TIES 6 REQUIRED
- ② 2" LODGEPOLE PINE STAKES (3) PER SPECIFICATIONS
- ③ REFER TO STANDARD MVLI-563-0 FOR IRRIGATION METHOD
- ④ BACKFILL MIX PER SPECIFICATIONS
- ⑤ 4" BERM FOR TEMPORARY WATERING UNTIL SEEDING
- ⑥ 3" THICK SHREDDED MULCH - WHERE APPLICABLE IN PLANTER BEDS
- ⑦ PLANTING PIT: 2 TIMES WIDTH OF ROOT BALL & SAME DEPTH AS ROOT BALL
- ⑧ TRUNK GUARD IN TURF AREAS
- ⑨ PLACE PLANT TABS PER MANUFACTURER'S RECOMMENDATION

NOTES:

- 1) INSTALL STAKES 12" MINIMUM FROM TREE TRUNK AND/OR OUTSIDE OF ROOTBALL.

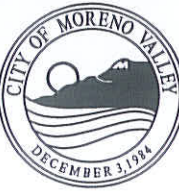
NOT TO SCALE

	RECOMMENDED:  DIVISION MANAGER DATE	CITY OF MORENO VALLEY FINANCIAL & MANAGEMENT SERVICES DEPARTMENT - SPECIAL DISTRICTS DIVISION	STANDARD PLAN MVLI-512A-0
	APPROVED:  PUBLIC WORKS DIRECTOR / DATE CITY ENGINEER	TRIPLE STAKE TREE	SHEET 1 OF 4

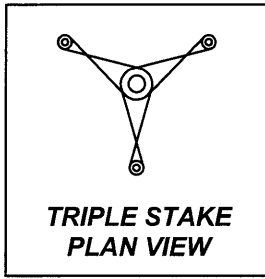
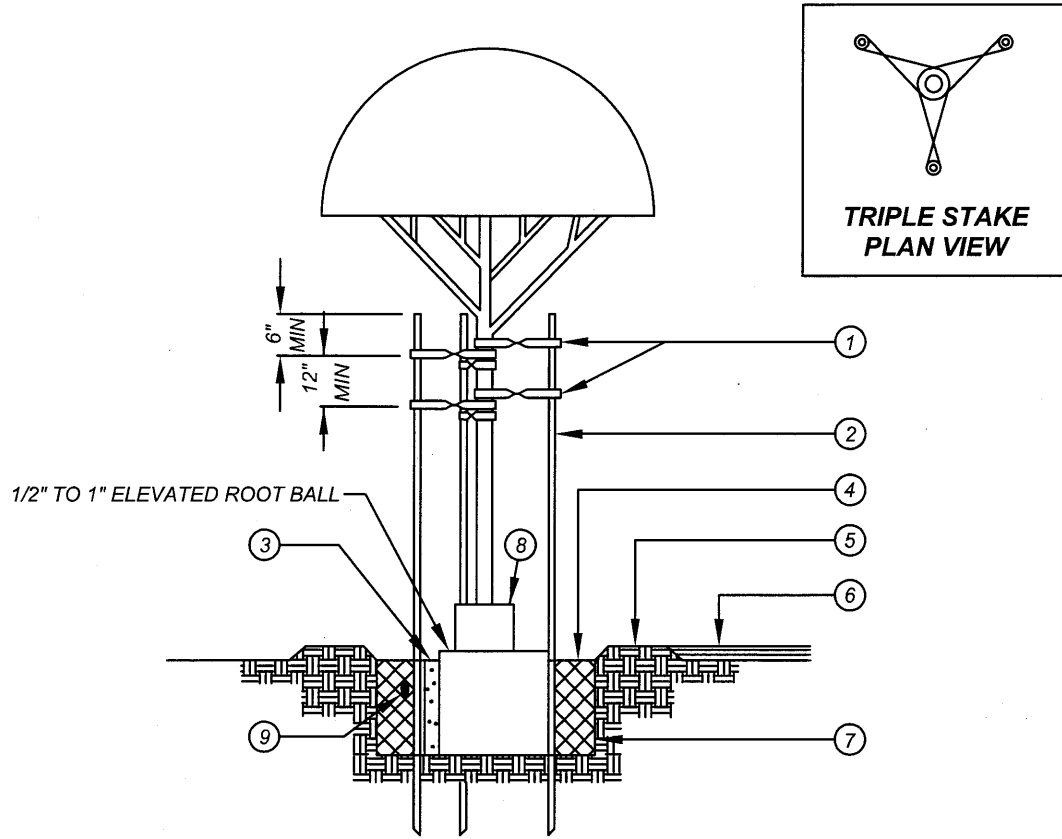



LEGEND:

- ① TREE TIES 6 REQUIRED
- ② 3" LODGEPOLE PINE STAKES (3) PER SPECIFICATIONS
- ③ REFER TO STANDARD MVLI-563 FOR IRRIGATION METHOD
- ④ BACKFILL MIX PER SPECIFICATIONS
- ⑤ 4" BERM FOR TEMPORARY WATERING UNTIL SEEDING/SODDING
- ⑥ 3" THICK SHREDDED BARK - WHERE APPLICABLE IN PLANTER BEDS
- ⑦ PLANTING PIT: 2 TIMES WIDTH OF ROOT BALL & SAME DEPTH AS ROOT BALL
- ⑧ TRUNK GUARD IN TURF AREAS
- ⑨ PLACE FERTILIZER PACKETS PER MANUFACTURER'S RECOMMENDATIONS

NOTES:

- 1) INSTALL STAKES 12" MINIMUM FROM TREE TRUNK AND/OR OUTSIDE OF ROOT BALL.

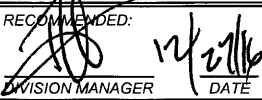
NOT TO SCALE

	RECOMMENDED:  DIVISION MANAGER DATE	CITY OF MORENO VALLEY PARKS AND COMMUNITY SERVICES DEPARTMENT	
	APPROVED:  PUBLIC WORKS DIRECTOR / DATE CITY ENGINEER	TRIPLE STAKE TREE	

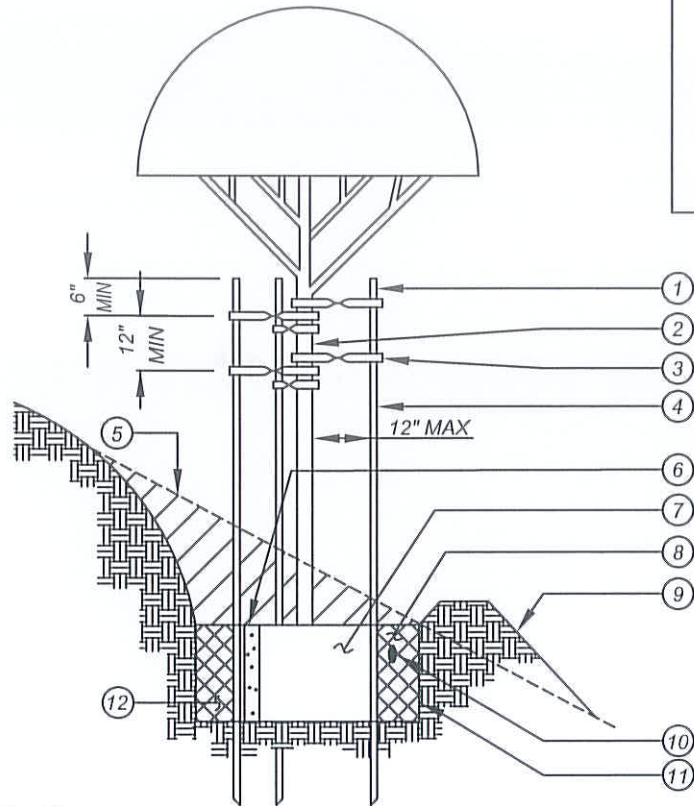
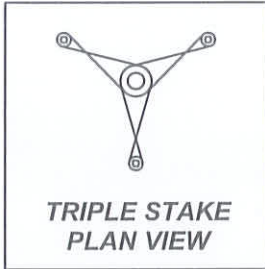

LEGEND:

- ① TOP OF STAKES
- ② MAIN TRUNK
- ③ TREE TIES (6 REQUIRED) 12" APART MIN. NAILED TO STAKES
- ④ APPROVED 10' TREE STAKES (3) PER SPECIFICATIONS
- ⑤ ORIGINAL GRADE
- ⑥ REFER TO STANDARD MVLI-563-0 FOR IRRIGATION METHOD
- ⑦ CONTAINER ROOT BALL
- ⑧ BACKFILL MIX PER SPECIFICATIONS
- ⑨ 4" BERM TIGHTLY COMPACTED IN PLACE TO FORM WATERING BASIN
- ⑩ PLANTING TABS PER MANUFACTURERS RECOMMENDATIONS
- ⑪ PLANTING PIT TO BE 2 TIMES WIDTH OF ROOT BALL & SAME DEPTH AS THE ROOT BALL
- ⑫ NATIVE SOIL BACKFILL (COMPACTED)

NOTES:

1) INSTALL STAKES 12" MINIMUM FROM TREE TRUNK AND/OR OUTSIDE OF ROOTBALL.

NOT TO SCALE

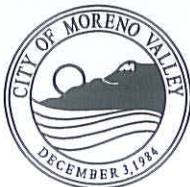

RECOMMENDED:
COS 1-16-14
 DIVISION MANAGER DATE
 APPROVED:
[Signature] 1/29/14
 PUBLIC WORKS DIRECTOR / DATE
 CITY ENGINEER

CITY OF MORENO VALLEY
 FINANCIAL & MANAGEMENT SERVICES DEPARTMENT - SPECIAL DISTRICTS DIVISION

TRIPLE STAKE TREE ON SLOPE

STANDARD PLAN
MVLI-512C-0

SHEET 3 OF 4

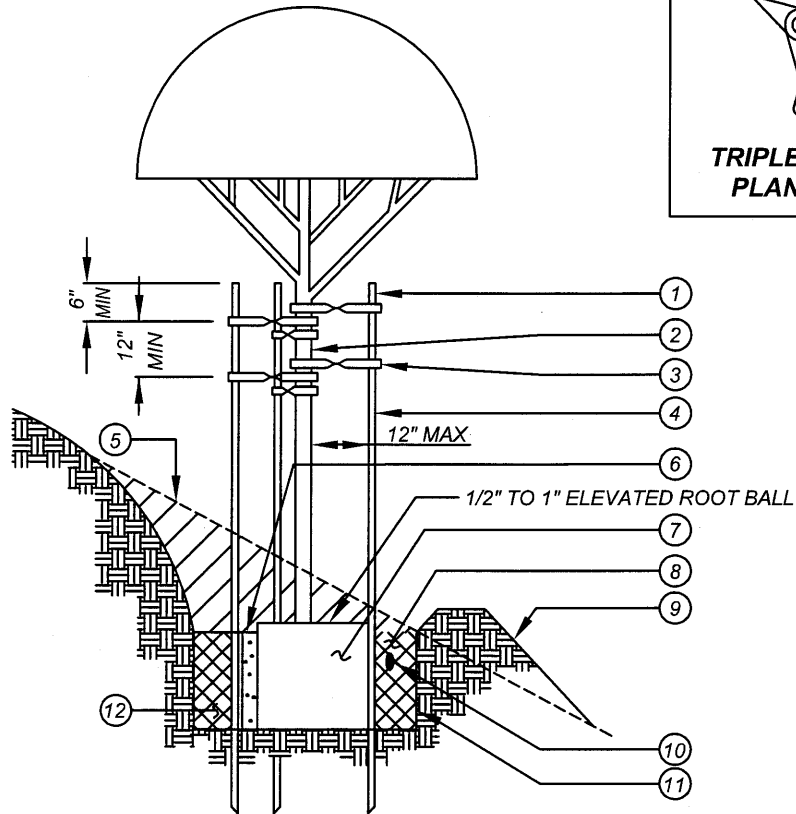
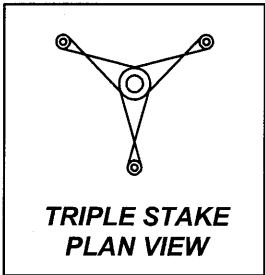

LEGEND:



- ① TOP OF STAKES
- ② MAIN TRUNK
- ③ TREE TIES (6 REQUIRED) 12" APART MIN NAILED TO STAKES
- ④ APPROVED 10' TREE STAKES (3) PER SPECIFICATIONS
- ⑤ ORIGINAL GRADE
- ⑥ REFER TO STANDARD MVLI-563 FOR IRRIGATION METHOD
- ⑦ CONTAINER ROOT BALL
- ⑧ BACKFILL MIX PER SPECIFICATIONS
- ⑨ 4" BERM TIGHTLY COMPACTED IN PLACE TO FORM WATERING BASIN
- ⑩ FERTILIZER PACKETS PER MANUFACTURERS RECOMMENDATIONS
- ⑪ PLANTING PIT TO BE 2 TIMES WIDTH OF ROOT BALL & SAME DEPTH AS THE ROOT BALL
- ⑫ BACKFILL PER SPECIFICATIONS

NOTES:

1) INSTALL STAKES 12" MINIMUM FROM TREE TRUNK AND/OR OUTSIDE OF ROOT BALL.

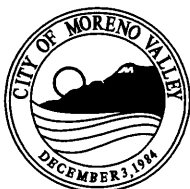
NOT TO SCALE

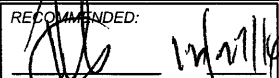

RECOMMENDED:

 DIVISION MANAGER DATE
 APPROVED:

 PUBLIC WORKS DIRECTOR / DATE
 CITY ENGINEER

CITY OF MORENO VALLEY

PARKS AND COMMUNITY SERVICES DEPARTMENT

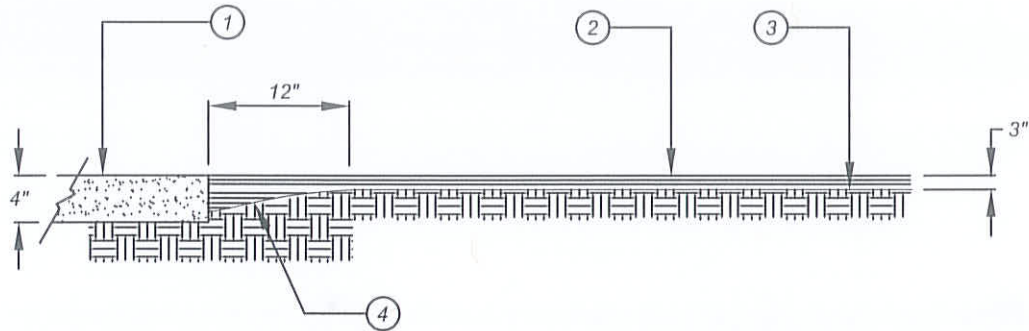
TRIPLE STAKE TREE ON SLOPE

STANDARD PLAN
MVLI-512D-1
 SHEET 4 OF 4





LEGEND:

- ① HARDCAPING/HEADERBOARD
- ② SHREDDED MULCH (PER PLAN AS SPECIFIED)
- ③ FINISH GRADE
- ④ SHOVEL CUT EDGE (ENSURE THAT BOTTOM EDGE OF SIDEWALK AND/OR HARDCAPE IS NOT EXPOSED)

NOTES:

- 1) MULCH UNDER TREES AND SHRUBS, AND BLEND EDGES AT GROUND COVER AREAS.
- 2) NOT TO BE USED WITH FLATTED PLANTS UNDER 16" ON CENTER.
- 3) PULL MULCH AWAY FROM ROOT CROWNS OF TREES & SHRUBS - AMOUNT PER THE DISCRETION OF SPECIAL DISTRICTS.

NOT TO SCALE

	RECOMMENDED:  1-10-14 DIVISION MANAGER / DATE	CITY OF MORENO VALLEY FINANCIAL & MANAGEMENT SERVICES DEPARTMENT - SPECIAL DISTRICTS DIVISION	
	APPROVED:  1/29/14 PUBLIC WORKS DIRECTOR / DATE CITY ENGINEER	MULCH INSTALLATION	

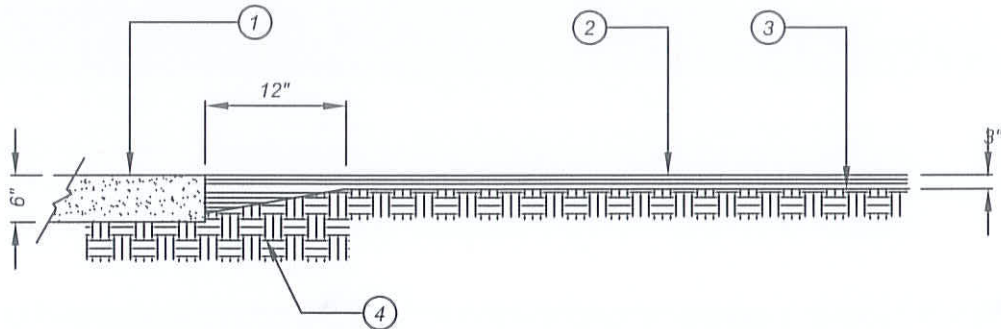

LEGEND:

- ① MOW CURB/HARDSCAPE/HEADER
- ② BARK / DG MULCH PER PARKS SPECIFICATIONS
- ③ FINISH GRADE
- ④ SHOVEL CUT EDGE

NOTES:

- 1) MULCH UNDER TREES AND SHRUBS, AND BLEND EDGES AT GROUND COVER AREAS.
- 2) NOT TO BE USED WITH ANNUAL FLOWERS.
- 3) PULL MULCH AWAY FROM ROOT CROWNS OF TREES & SHRUBS.
- 4) DETAIL CAN BE USED FOR PALM SPRINGS GOLD SAND OR DECOMPOSED GRANITE IN PLANTERS.

NOT TO SCALE

	RECOMMENDED: <i>JH</i> 1/21/14 DIVISION MANAGER DATE	CITY OF MORENO VALLEY PARKS AND COMMUNITY SERVICES DEPARTMENT	
	APPROVED: <i>[Signature]</i> 1/29/14 PUBLIC WORKS DIRECTOR / DATE CITY ENGINEER	BARK INSTALLATION	

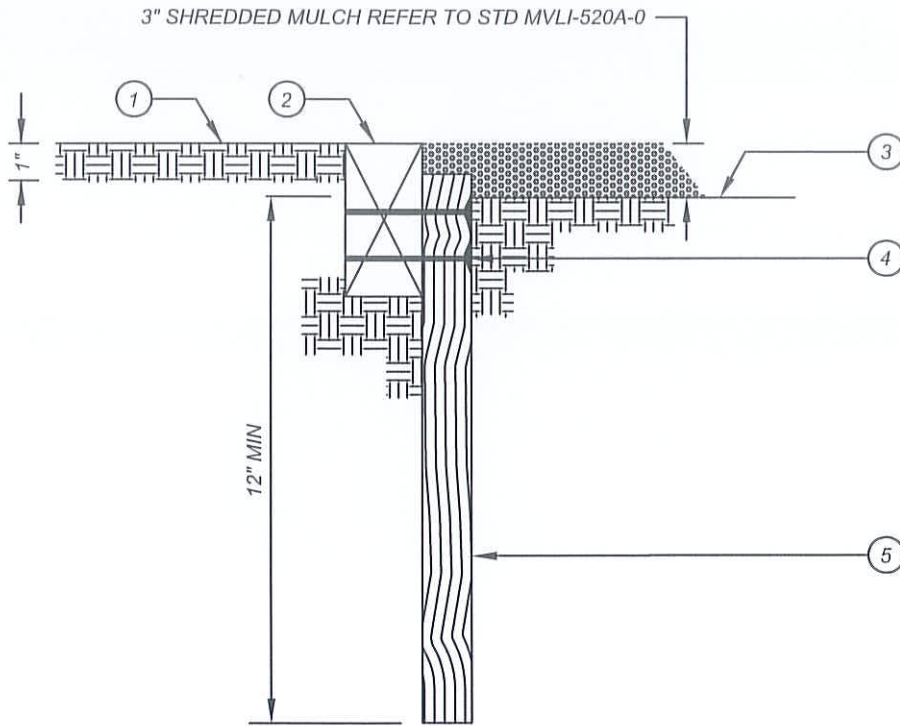



LEGEND:

- ① FINISH GRADE
- ② 2 x 4 ROUGH SAWN REDWOOD HEADER BOARD (NOTCH) OR INSTALL AT GRADE LEVEL AT SWALE CROSSING
- ③ FINISH GRADE IN PLANT BED
- ④ 8d GALVANIZED NAILS (2)
- ⑤ 2" x 2" x 24" REDWOOD STAKES AT 3' OC AND AT ALL SPLICES

NOTES:

- 1.) 24" LAP ALL SPLICES. USE ROUGH SAWN LUMBER UNLESS OTHERWISE APPROVED BY THE CITY
 - 2.) CURVED SECTIONS OF HEADER SHALL BE CONSTRUCTED OF THREE 3/8" x 4" LAMINATED REDWOOD BENDER BOARD
- NOT TO SCALE

	RECOMMENDED:  1-16-14 DIVISION MANAGER DATE	CITY OF MORENO VALLEY FINANCIAL & MANAGEMENT SERVICES DEPARTMENT - SPECIAL DISTRICTS DIVISION	STANDARD PLAN MVLI-521-0
	APPROVED:  1/29/14 PUBLIC WORKS DIRECTOR / DATE CITY ENGINEER	2" x 4" REDWOOD HEADER	

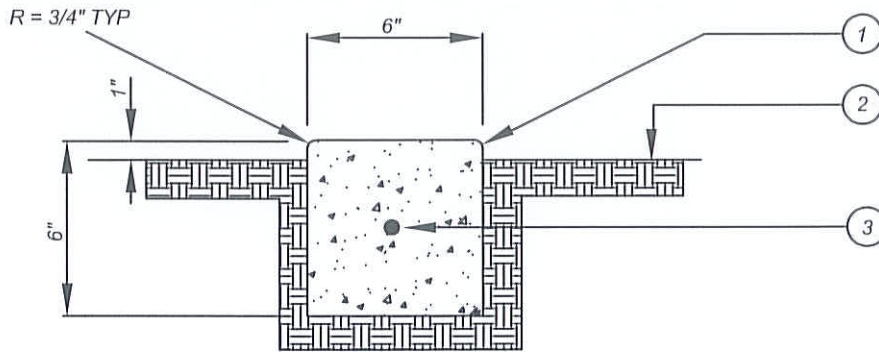



LEGEND:

- ① CONCRETE MOW CURB - 3/4" RADIUS EXPOSED EDGES. MEDIUM BROOM FINISH OR PER PLAN (INSTALL GRADE LEVEL AT SWALE CROSSING)
- ② FINISH GRADE
- ③ #4 REBAR CONTINUOUS

NOTE:

- 1.) PROVIDE DEEP SCORE JOINTS AT 8' OC AND 3/8" RUBBER EXPANSION JOINTS AT 24' OC.
- 2.) CONCRETE SHALL BE 560-C-3250.

NOT TO SCALE

	RECOMMENDED:  1.16.14 DIVISION MANAGER DATE	CITY OF MORENO VALLEY FINANCIAL & MANAGEMENT SERVICES DEPARTMENT - SPECIAL DISTRICTS DIVISION	STANDARD PLAN
	APPROVED:  1/29/14 PUBLIC WORKS DIRECTOR / DATE CITY ENGINEER		6" WIDE CONCRETE MOW CURB
			SHEET 1 OF 3

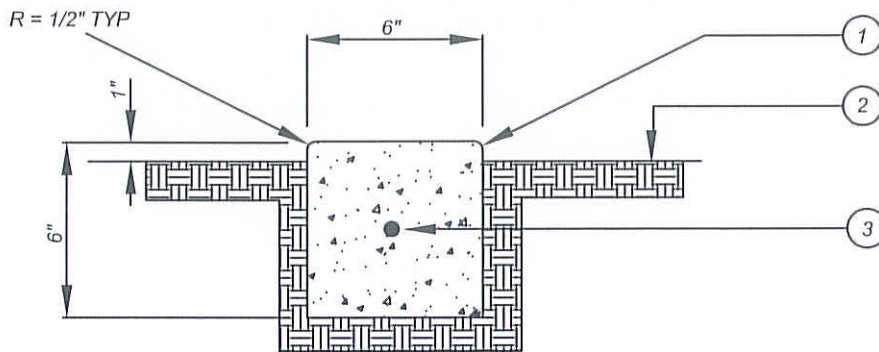

LEGEND:

- ① CONCRETE MOW CURB - 1/2" RADIUS EXPOSED EDGES. MEDIUM BROOM FINISH OR PER PLAN (INSTALL GRADE LEVEL AT SWALE CROSSING)
- ② FINISH GRADE
- ③ #4 REBAR CONTINUOUS

NOTE:

- 1.) PROVIDE 1/2" DEEP SCORE JOINTS AT 8' OC AND 3/8" RUBBER EXPANSION JOINTS AT 50' OC.
- 2.) CONCRETE SHALL BE 560-C-3250 OR 660-C-4000 FOR PUMP MIX.
- 3.) COLOR PER PLAN OR SPECIFICATIONS.
- 4.) CONCRETE FINISH AS REQUIRED.

NOT TO SCALE

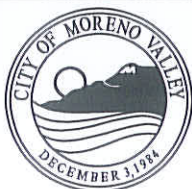

RECOMMENDED:
 [Signature] 1/20/14
 DIVISION MANAGER DATE
 APPROVED:
 [Signature] 1/29/14
 PUBLIC WORKS DIRECTOR DATE
 CITY ENGINEER

CITY OF MORENO VALLEY

PARKS AND COMMUNITY SERVICES DEPARTMENT

6" WIDE CONCRETE MOW CURB

STANDARD PLAN
MVLI-522B-0

SHEET 2 OF 3

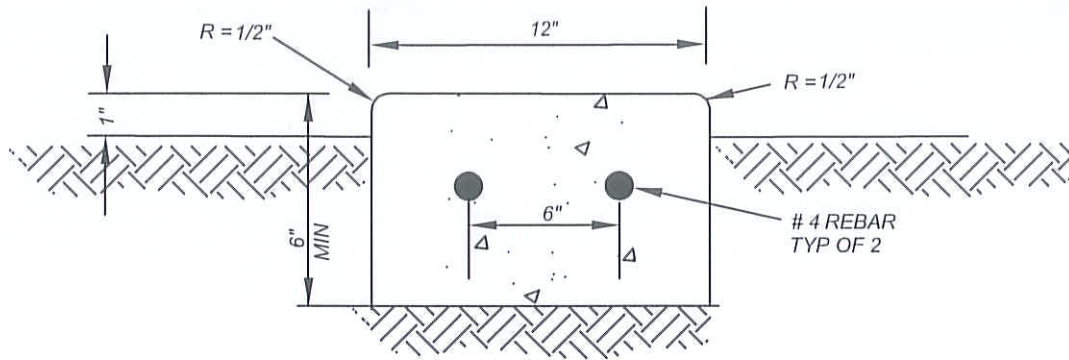

NOTES:

- 1.) CONCRETE MOW STRIP REQUIRED NEXT TO LANDSCAPED AREAS & UNDER FENCES FOR PARK SITES.
- 2.) CONCRETE TYPE IS 560-C-3250 MINIMUM (OR 660-C-4000 FOR PUMP MIX). NO FLY ASH.
- 3.) CONCRETE COLOR PER PLAN OR SPECIFICATIONS.
- 4.) FINISH AS REQUIRED.

NOT TO SCALE

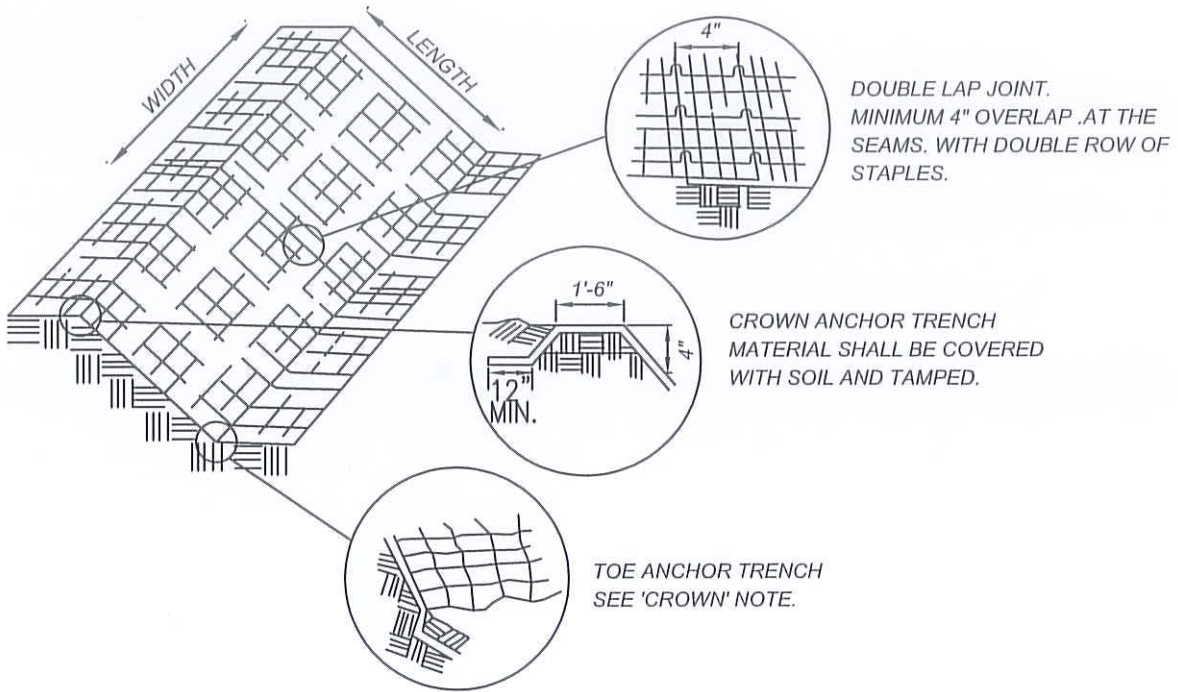

	RECOMMENDED: DIVISION MANAGER 1/21/14 DATE	CITY OF MORENO VALLEY PARKS AND COMMUNITY SERVICES DEPARTMENT	STANDARD PLAN MVLI-522C-0
	APPROVED: PUBLIC WORKS DIRECTOR / DATE CITY ENGINEER 1/29/14	12" WIDE CONCRETE MOW CURB	SHEET 3 OF 3



NOTES:

- 1.) GROUND COVER MAY BE PLANTED THROUGH THE FABRIC.
- 2.) THE FABRIC SHALL BE INSTALLED ON GROUND A MINIMUM OF 48 HOURS PRIOR TO PLANTING TO ALLOW FABRIC TO SETTLE.
- 3.) HOLES FOR PLANTING SHALL BE MADE WITH SHARP KNIVES OR SHEARS.
- 4.) FABRIC IS TO BE FASTENED USING No 11 GAUGE WIRE. 'U' SHAPED WITH 1" CROWN AND LESS 12" IN LENGTH OR PREFABRICATED STAPLES.
- 5.) INSTALLATION PER MANUFACTURES SPECIFICATIONS.

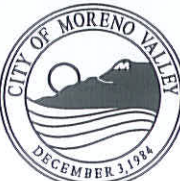
NOT TO SCALE

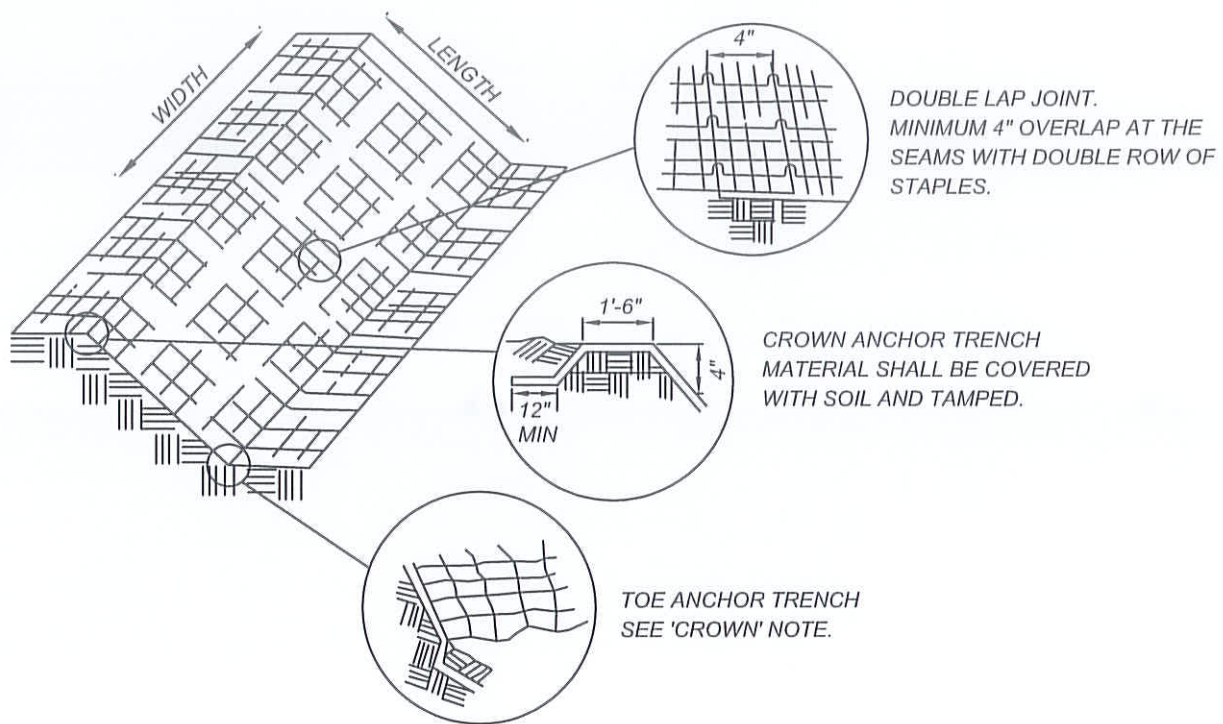

	RECOMMENDED:  1-16-14 DIVISION MANAGER DATE	CITY OF MORENO VALLEY FINANCIAL & MANAGEMENT SERVICES DEPARTMENT - SPECIAL DISTRICTS DIVISION	
	APPROVED:  1/29/14 PUBLIC WORKS DIRECTOR / DATE CITY ENGINEER	EROSION CONTROL NETTING (LANDSCAPING)	



NOTES:

- 1.) GROUND COVER / SHRUBS MAY BE PLANTED THROUGH THE FABRIC.
- 2.) THE FABRIC SHALL BE INSTALLED ON GROUND A MINIMUM OF 48 HOURS PRIOR TO PLANTING TO ALLOW FABRIC TO SETTLE.
- 3.) HOLES FOR PLANTING SHALL BE MADE WITH SHARP KNIVES OR SHEARS.
- 4.) FABRIC IS TO BE FASTENED USING No 11 GAUGE WIRE. 'U' SHAPED WITH 1" CROWN AND LESS 12" IN LENGTH OR PREFABRICATED STAPLES.
- 5.) INSTALLATION PER MANUFACTURE'S SPECIFICATIONS.
- 6.) DRIP IRRIGATION TO BE INSTALLED UNDER FABRIC.
- 7.) NETTING TO BE USED ON SLOPES GREATER THAN 4:1

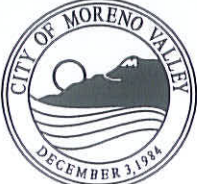
NOT TO SCALE

	RECOMMENDED:  1/21/14 DIVISION MANAGER DATE	CITY OF MORENO VALLEY PARKS AND COMMUNITY SERVICES DEPARTMENT	
	APPROVED:  1/29/14 PUBLIC WORKS DIRECTOR / DATE CITY ENGINEER	EROSION CONTROL NETTING (LANDSCAPING)	

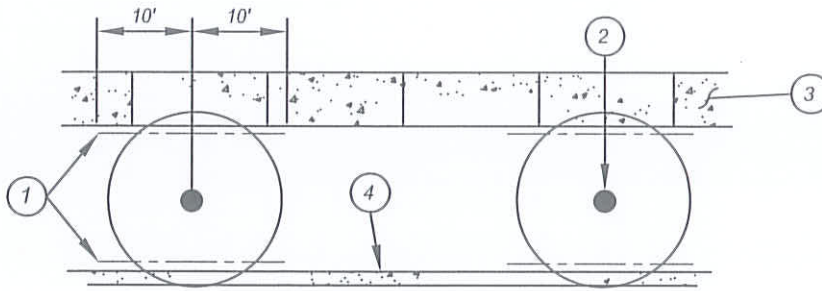

PLAN

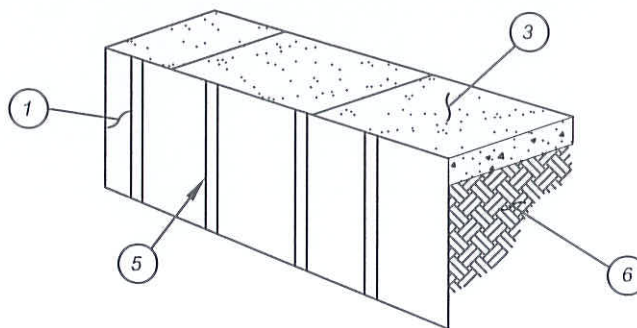

ELEVATION

LEGEND:

- (1) 24" DEEP LINEAR ROOT BARRIER (PER PLAN AS SPECIFIED). INSTALL IN TRENCH WITH VERTICAL RIBS FACING TOWARDS THE TREE. TOP OF BARRIER TO EXTEND TO TOP OF CURB OR WALK, OR 1" ABOVE FINISH GRADE.
- (2) TREE TRUNK LOCATION.
- (3) CONCRETE SIDEWALK OR SLAB.
- (4) CONCRETE CURB OR SITE WALL.
- (5) VERTICAL RIBS.
- (6) COMPACTED SUBGRADE.

NOT TO SCALE

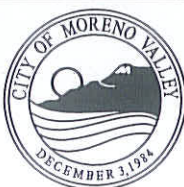

RECOMMENDED:
 [Signature] 1.16.14
 DIVISION MANAGER DATE
 APPROVED:
 [Signature] 1/29/14
 PUBLIC WORKS DIRECTOR / DATE
 CITY ENGINEER

CITY OF MORENO VALLEY
 FINANCIAL & MANAGEMENT SERVICES DEPARTMENT - SPECIAL DISTRICTS DIVISION

LINEAR ROOT BARRIER

STANDARD PLAN
MVLI-524A-0

SHEET 1 OF 2

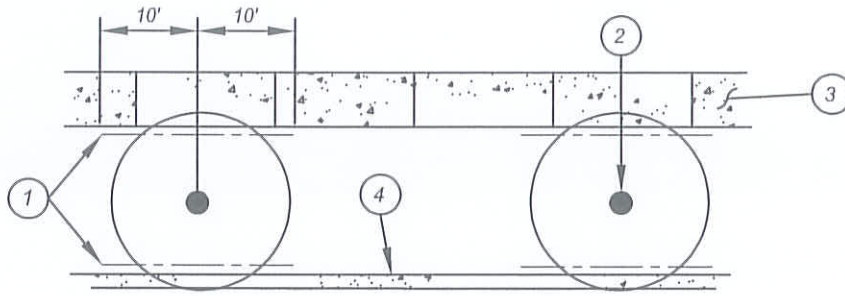

PLAN

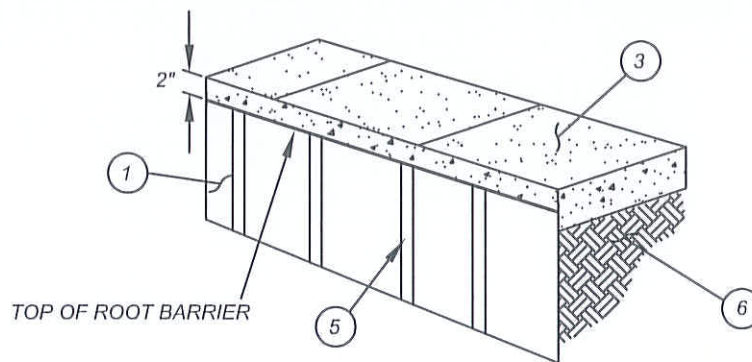

ELEVATION

LEGEND:

- ① 24" DEEP LINEAR ROOT BARRIER (PER PLAN AS SPECIFIED). INSTALL IN TRENCH WITH VERTICAL RIBS FACING TOWARDS THE TREE. TOP OF BARRIER TO EXTEND TO TOP OF CURB OR WALK, OR 1" ABOVE FINISH GRADE.
- ② TREE TRUNK LOCATION.
- ③ CONCRETE SIDEWALK OR SLAB.
- ④ CONCRETE CURB OR SITE WALL.
- ⑤ VERTICAL RIBS.
- ⑥ COMPACTED SUBGRADE.

NOT TO SCALE

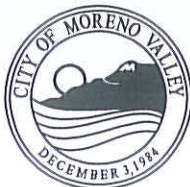

RECOMMENDED:
 [Signature] 1/21/14
 DIVISION MANAGER DATE
 APPROVED:
 [Signature] 1/29/14
 PUBLIC WORKS DIRECTOR/ DATE
 CITY ENGINEER

CITY OF MORENO VALLEY
 PARKS AND COMMUNITY SERVICES DEPARTMENT

LINEAR ROOT BARRIER

STANDARD PLAN
MVLI-524B-0

SHEET 2 OF 2

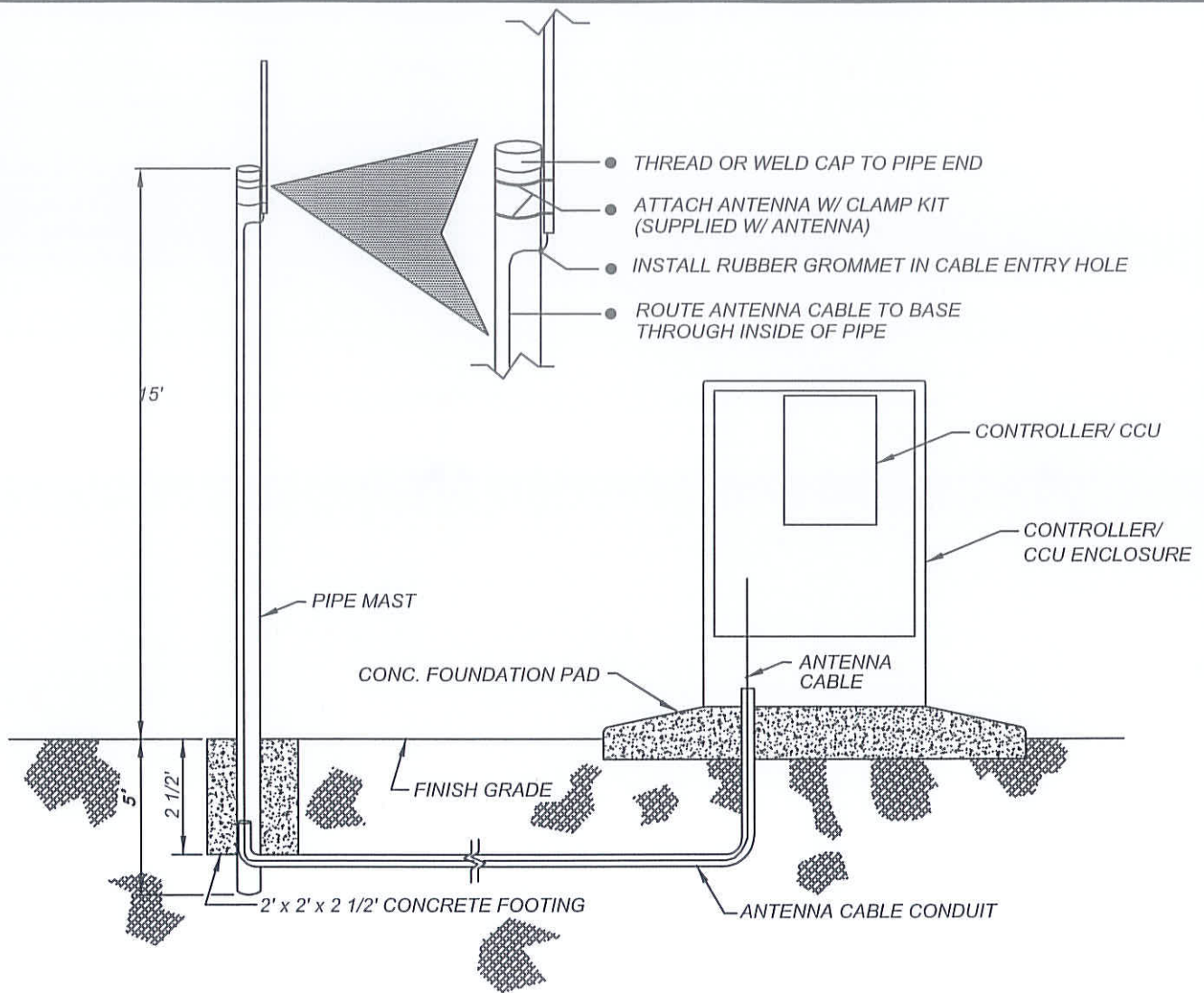

NOTES:

- 1) RADIO ANTENNA MAST SHALL BE 2" THREADED STEEL PIPE STOCK & FITTINGS.
- 2) ANTENNA MAST SURFACE COATING SHALL BE GLYD-ZINC Y-5537 - GREY-GREEN (OR APPROVED EQUAL)
- 3) ANTENNA LEAD WIRE SWEEPS / CONDUIT TO BE SCHD 40 PVC ALL SWEEPS TO BE 1" MIN DIA EXTEND CONDUIT ALONG THE ENTIRE REACH OF LEAD WIRE PATH, ENDING IN CCU ENCLOSURE
- 4) ANTENNA CABLE SHALL EXTEND INTO ENCLOSURE 18" PAST END OF SWEEP.
- 5) SEE CITY STANDARD EQUIPMENT LIST FOR MANUFACTURER

NOT TO SCALE

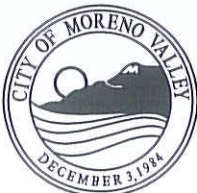

RECOMMENDED:
 COS 1.16.14
 DIVISION MANAGER DATE
 APPROVED:
 [Signature] 1/29/14
 PUBLIC WORKS DIRECTOR / DATE
 CITY ENGINEER

CITY OF MORENO VALLEY
 FINANCIAL & MANAGEMENT SERVICES DEPARTMENT - SPECIAL DISTRICTS DIVISION

**CLUSTER CONTROL UNIT
 RADIO LINK ANTENNA &
 ENCLOSURE DETAIL**

STANDARD PLAN
MVLI-530-0

SHEET 1 OF 1

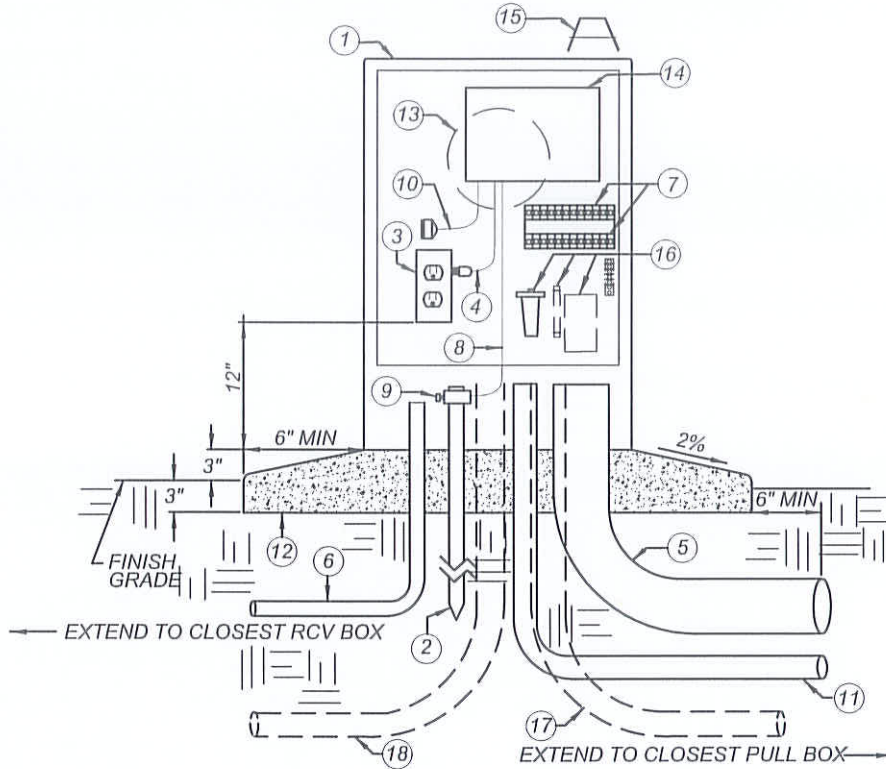



LEGEND:

- 1) ELECTRICAL METER/IRRIGATION CONTROLLER ENCLOSURE W/ 110 VAC SERVICE PANEL-DOUBLE DOOR-STAINLESS STEEL
- 2) 5/8" x 8' COPPER-CLAD GROUNDING ROD (GROUND 110 & CONTROLLER)
- 3) DUPLEX OUTLET (CONDUIT PATH TO SERVICE PANEL PER CODE). INSTALL W/ SURGE ARRESTOR - ISOBAR ULTRABLOCK 428
- 4) APPLIANCE GRADE 110 VAC 3-WIRE CONDUCTOR POWER CORD (SIZED TO REACH DUPLEX OUTLET). SECURE TO CONTROLLER CABINET
- 5) 3" SCH. 40 E.C. SWEEP ELL FOR 14 GA. UF CONTROL WIRE ONLY
- 6) 3/4" SCH. 40 E.C. SWEEP ELL W/ NYLON PULL ROPE FOR FUTURE MOISTURE SENSOR WIRING
- 7) TERMINAL STRIP(S) FOR CONNECTION OF 14 GA. UF FIELD WIRE FROM SWEEP. USE 16 GA. UTILITY WIRE TO CONNECT
- 8) #10 SOLID COPPER WIRE FROM GROUNDING ROD TO CONTROLLER GROUND LUG
- 9) BRASS / BRONZE GROUND CLAMP
- 10) ETHERNET (RS232 PORT INCLUDED)
- 11) TELEMETRY CONDUIT - 1 1/2" SCH 40. EXTEND PE 39 CABLE INTO ENCLOSURE 18" MIN. FROM END OF SWEEP (USE FOR MAXICOM WIRE LINK / FLOW SENSOR WIRE LINK @ 1 PER EA.)
- 12) 6" THICK CONCRETE FOOTING POURED ON COMPACTED SUBGRADE (95% RELATIVE COMPACTION). RADIUS EDGES @ 1/2"
- 13) ELECTRIC METER
- 14) IRRIGATION CONTROLLER - MODEL # PER PLAN CALL-OUT WITH REMOTE CONTROL ACCTUATOR INTERFACE-PER PLAN
- 15) ANTENNA - RADIO LINKED MAXICOM ONLY - MODEL # PER PLAN CALL-OUT
- 16) FLOW SENSING COMPONENTS (INSTALL IF SHOWN ON PLAN) - MODEL #'S PER PLAN CALL-OUT
- 17) 2 1/2" SCH 40 ELECTRICAL CONDUIT
- 18) 1" SCH 40 ELECTRICAL CONDUIT

NOTES:

- 1) COMMON WIRE TO BE 12 GA. WHITE. PILOT WIRES TO BE 14 GA. BLACK.
- 2) NO SPLICES ALLOWED BETWEEN TERMINAL STRIP AND RCV.
- 3) INSTALL ONE (1) EXTRA PILOT WIRE (RED) TO FARTHEST RCV IN ANY / ALL DIRECTIONS FROM ENCLOSURE. LOOP INTO EACH VALVE BOX ALONG WIRE PATH.
- 4) IF FLOW SENSOR TO BE INSTALLED, INCLUDE 3/4" CONDUIT PATH FROM ENCLOSURE TO SENSOR VAULT.
- 5) SEE CITY STANDARD EQUIPMENT LIST FOR MANUFACTURER.

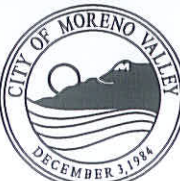
NOT TO SCALE

	RECOMMENDED: 	CITY OF MORENO VALLEY FINANCIAL & MANAGEMENT SERVICES DEPARTMENT - SPECIAL DISTRICTS DIVISION	
	DIVISION MANAGER DATE 1-26-14	CONTROLLER / SATELLITE ENCLOSURE DETAIL	
APPROVED: 		SHEET 1 OF 2	
PUBLIC WORKS DIRECTOR / DATE CITY ENGINEER			

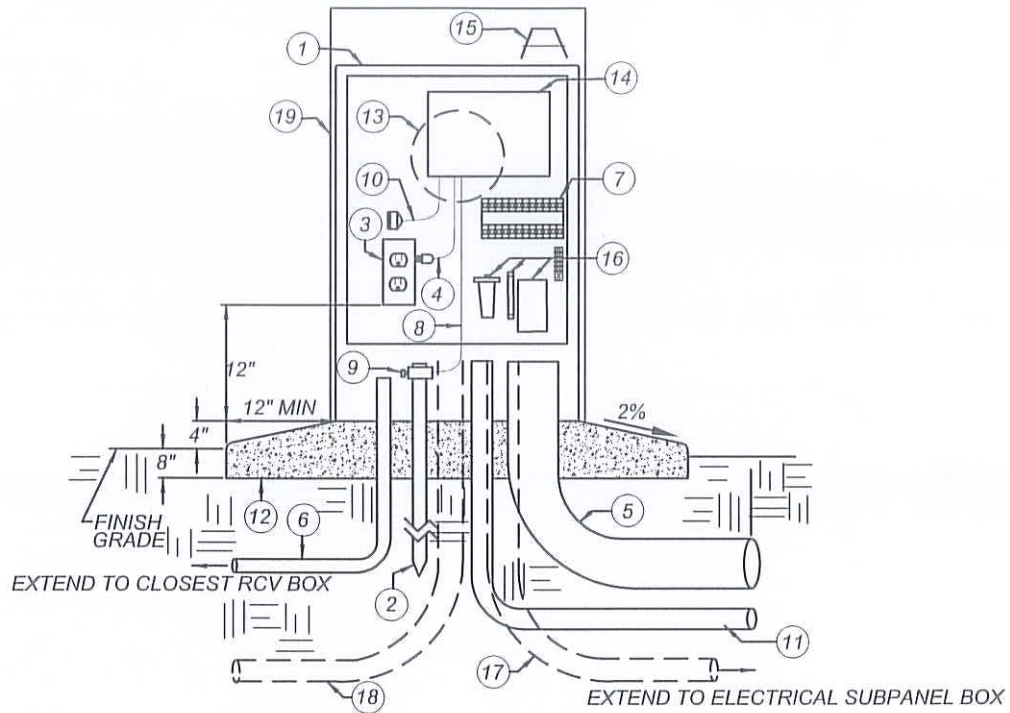



LEGEND:

- ① ELECTRICAL METER/IRRIGATION CONTROLLER ENCLOSURE PER SPECIFICATIONS
- ② 5/8" x 8' COPPER-CLAD GROUNDING ROD (GROUND 110 & CONTROLLER)
- ③ DUPLEX OUTLET (CONDUIT PATH TO SERVICE PANEL PER CODE). INSTALL W/ SURGE ARRESTOR - ISOBAR ULTRABLOCK 428
- ④ APPLIANCE GRADE 110 VAC 3-WIRE CONDUCTOR POWER CORD (SIZED TO REACH DUPLEX OUTLET). SECURE TO CONTROLLER CABINET
- ⑤ 4" SCH 40 E.C. SWEEP ELL FOR UF CONTROL WIRE ONLY
- ⑥ 3/4" SCH 40 E.C. SWEEP ELL W/ NYLON PULL ROPE FOR FUTURE MOISTURE SENSOR WIRING
- ⑦ TERMINAL STRIP FOR CONNECTION OF UF FIELD WIRE FROM SWEEP.
- ⑧ TERMINAL STRIP TO CONTROLLER (TYP.)
- ⑨ #6 SOLID COPPER WIRE FROM GROUNDING ROD TO CONTROLLER GROUND LUG
- ⑩ BRASS / BRONZE GROUND CLAMP
- ⑪ TELEMETRY CONDUIT - 3/4". EXTEND RAIN / WEATHER SENSOR CABLE INTO ENCL 36" MIN. FROM END OF SWEEP
- ⑫ 12" THICK CONCRETE FOOTING POURED ON COMPACTED SUBGRADE (95% COMPACTION). RADIUS EDGES @ 1/2"
- ⑬ ELECTRIC METER
- ⑭ IRRIGATION CONTROLLER - MODEL # PER PLAN CALL-OUT
- ⑮ RAIN GAUGE / WEATHER SENSOR - MODEL # PER PLAN CALL-OUT
- ⑯ FLOW SENSING COMPONENTS (INSTALL IF SHOWN ON PLAN) - MODEL #'S PER PLAN CALL-OUT
- ⑰ 2 1/2" SCH 40 ELECTRICAL CONDUIT
- ⑱ 1" SCH 40 ELECTRICAL CONDUIT
- ⑲ STAINLESS STEEL VANDAL PROOF MESH COVER PER SPECIFICATIONS

NOTES:

- 1) COMMON WIRE TO BE WHITE, PER SPECIFICATIONS. PILOT WIRES TO BE SIZED AND COLOR PER SPECIFICATIONS.
- 2) NO SPLICES ALLOWED BETWEEN TERMINAL STRIP AND RCV.
- 3) INSTALL EXTRA WIRES PER SPECIFICATION TO FARTHEST RCV IN ANY / ALL DIRECTIONS FROM ENCLOSURE. LOOP INTO EACH VALVE BOX ALONG WIRE PATH.
- 4) IF FLOW SENSOR AND/OR MASTER VALVE IS INSTALLED, INCLUDE 3/4" CONDUIT PATH FROM ENCLOSURE TO VAULTS.
- 5) SEE CITY STANDARD EQUIPMENT LIST FOR MANUFACTURER.

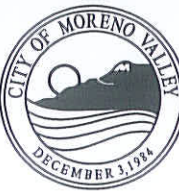
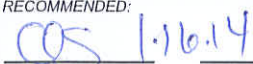
NOT TO SCALE

	RECOMMENDED:  DIVISION MANAGER DATE	<h2 style="margin: 0;">CITY OF MORENO VALLEY</h2> <p style="margin: 0;">FINANCIAL & MANAGEMENT SERVICES DEPARTMENT - SPECIAL DISTRICTS DIVISION</p>	STANDARD PLAN <h3 style="margin: 0;">MVLI-531B-0</h3>
	APPROVED:  PUBLIC WORKS DIRECTOR / DATE CITY ENGINEER	<h3 style="margin: 0;">SMART CONTROLLER ENCLOSURE DETAIL</h3>	SHEET 2 OF 2

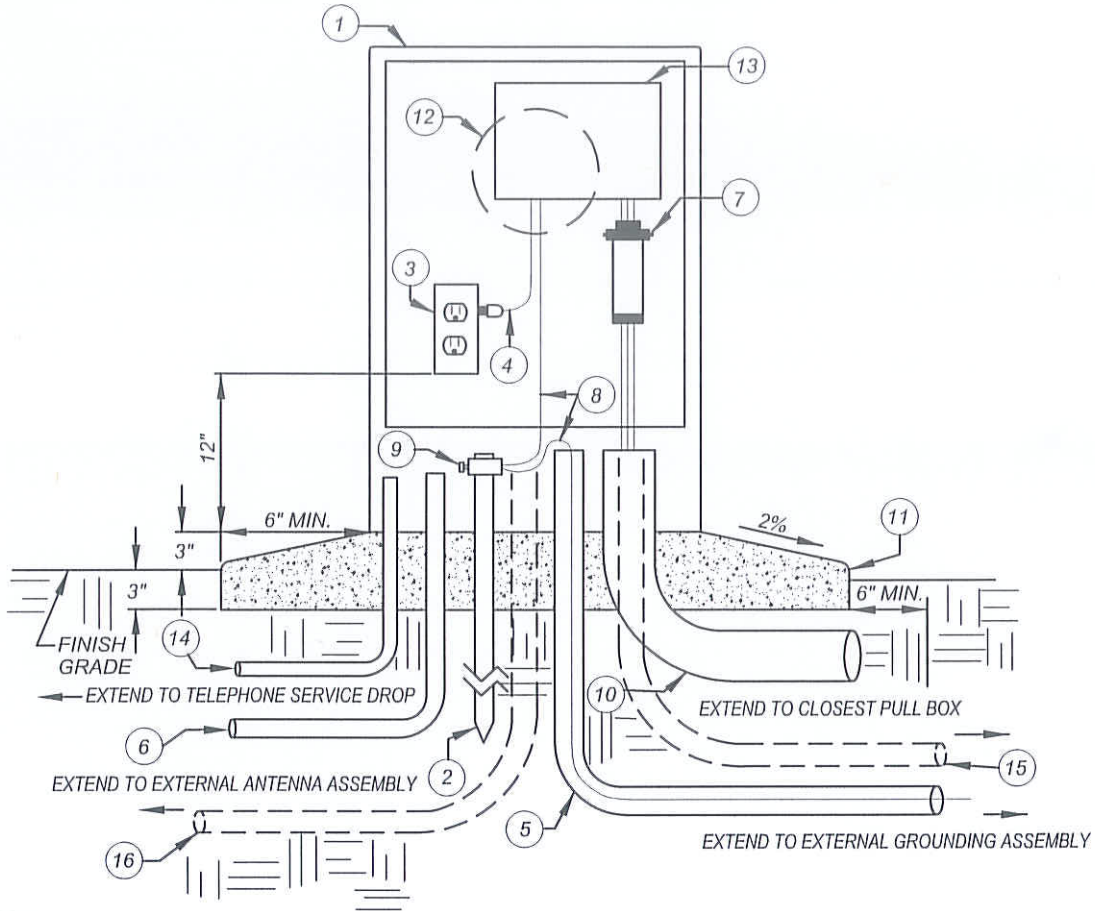

LEGEND:

- ① ELECTRICAL METER/IRRIGATION CONTROLLER ENCLOSURE W/ 110 VAC SERVICE PANEL-DOUBLE DOOR-STAINLESS STEEL
- ② 5/8" x 8' COPPER-CLAD GROUNDING ROD (GROUND 110 & CONTROLLER)
- ③ DUPLEX OUTLET (CONDUIT PATH TO SERVICE PANEL PER CODE). INSTALL W/ SURGE ARRESTOR - ISOBAR ULTRAFAX
- ④ APPLIANCE GRADE 110 VAC 3-WIRE CONDUCTOR POWER CORD (SIZED TO REACH DUPLEX OUTLET). SECURE TO CONTROLLER CABINET
- ⑤ 1" SCH 40 E.C. SWEEP ELL FOR EXTERNAL GROUNDING ASSEMBLY
- ⑥ 1-1/2" SCH 40 E.C. SWEEP ELL FOR EXTERNAL ANTENNA ASSEMBLY (MAXICOM RADIO LINK ONLY)
- ⑦ TELEMETRY CABLE SURGE ARRESTOR (RAINBIRD MSP-1). INSTALL PER MFG.'S DIRECTIONS
- ⑧ #10 SOLID COPPER WIRE FROM GROUNDING ROD TO CONTROLLER GROUND LUG-GREEN INSULATION
- ⑨ BRASS / BRONZE GROUND CLAMP
- ⑩ TELEMETRY CONDUIT - 1-1/2" SCH 40. EXTEND PE 39 CABLE 18" MIN. FROM TOP END OF SWEEP (ELIMINATE SWEEP IF RADIO LINKED MAXICOM)
- ⑪ 6" THICK CONCRETE FOOTING POURED ON COMPACTED SUBGRADE (95% RELATIVE COMPACTION). RADIUS EDGES @ 1/2"
- ⑫ ELECTRIC METER
- ⑬ CCU PER PLAN CALL-OUT
- ⑭ SCH. 40 PVC SWEEP ELL W/ NYLON PULL ROPE FOR TELEPHONE SERVICE DROP - SIZE PER PLAN
- ⑮ 2-1/2" SCH 40 ELECTRICAL CONDUIT
- ⑯ 1" SCH 40 ELECTRICAL CONDUIT

NOT TO SCALE

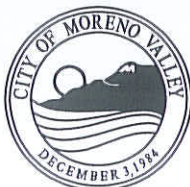

RECOMMENDED:
COS 1.16.14
 DIVISION MANAGER DATE
 APPROVED:
[Signature] 1/29/14
 PUBLIC WORKS DIRECTOR/ DATE
 CITY ENGINEER

CITY OF MORENO VALLEY
 FINANCIAL & MANAGEMENT SERVICES DEPARTMENT - SPECIAL DISTRICTS DIVISION

**CLUSTER CONTROL UNIT
 ENCLOSURE DETAIL**

STANDARD PLAN
MVLI-532-0

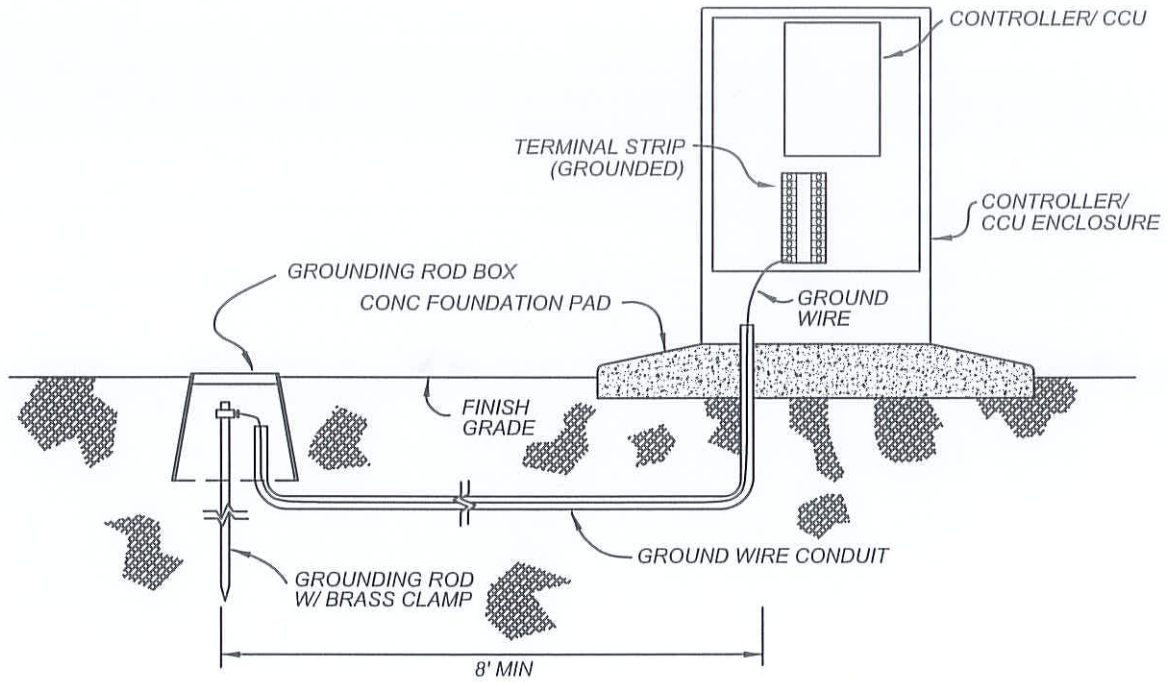

SHEET 1 OF 1



NOTES:

- 1) GROUND WIRE SHALL BE No 10 COPPER (INSULATED - GREEN).
- 2) GROUNDING ROD SHALL BE 5/8" x 8'-0" COPPER CLAD.
- 3) ATTACH GROUND WIRE TO GROUNDING ROD USING BRASS GROUND ROD CLAMP.
- 4) ENCLOSE GROUND ROD IN 10 - INCH ROUND PLASTIC VALVE BOX W / LOCKING LID.
- 5) CONNECT FIELD GROUND WIRE TO TERMINAL STRIP.
- 6) SWEEPS / CONDUIT TO BE 1" SCH 80 PVC. EXTEND CONDUIT ALONG THE ENTIRE REACH OF GROUND WIRE PATH, ENDING IN GROUND ROD BOX.

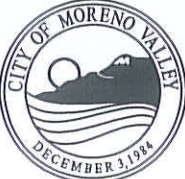
NOT TO SCALE

	RECOMMENDED:  1-16-14 DIVISION-MANAGER DATE	CITY OF MORENO VALLEY FINANCIAL & MANAGEMENT SERVICES DEPARTMENT - SPECIAL DISTRICTS DIVISION	STANDARD PLAN MVLI-533-0
	APPROVED:  1/29/14 PUBLIC WORKS DIRECTOR / DATE CITY ENGINEER	EXTERNAL GROUND ROD ASSEMBLY DETAIL	

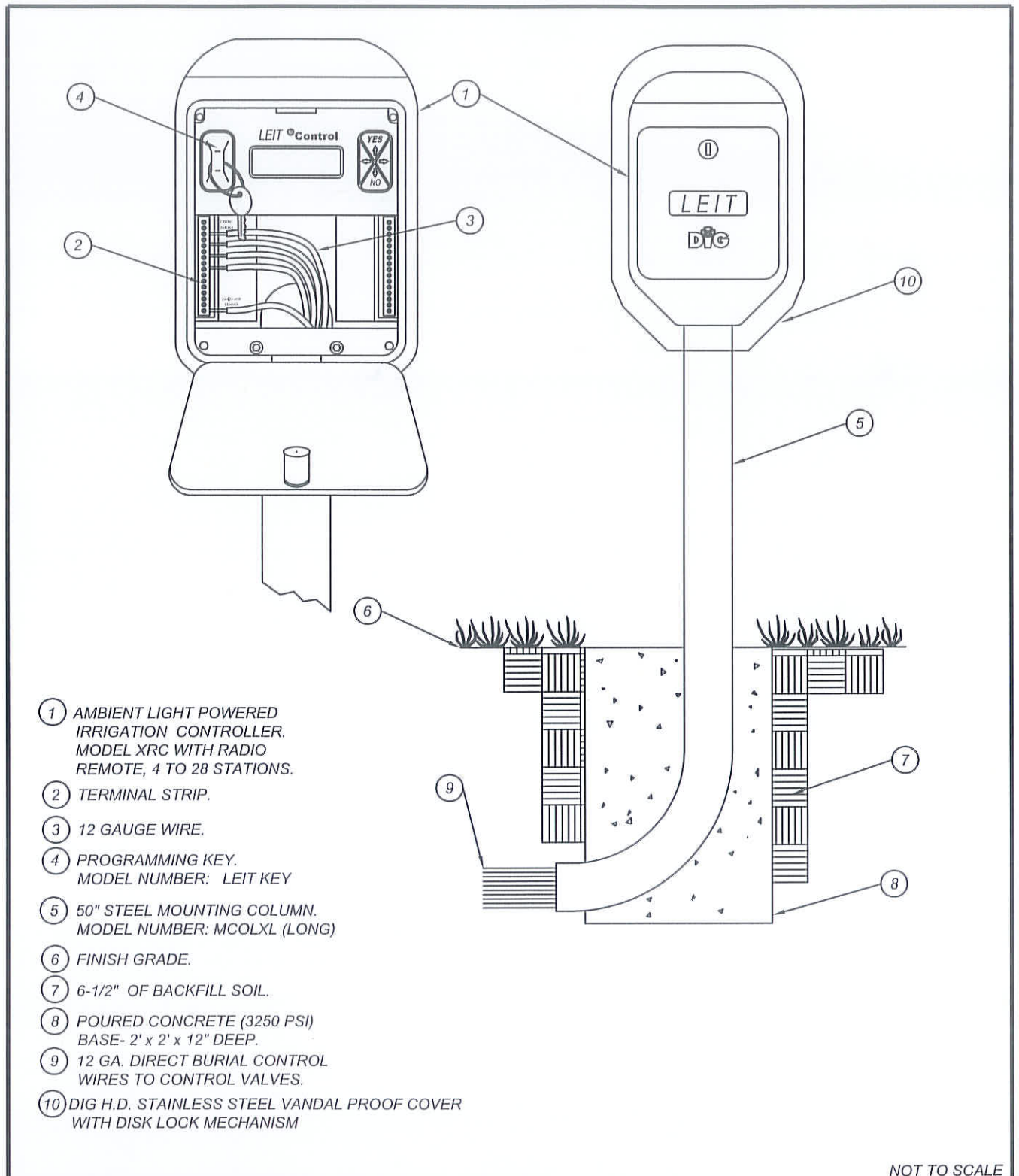

- 1 AMBIENT LIGHT POWERED IRRIGATION CONTROLLER. MODEL XRC WITH RADIO REMOTE, 4 TO 28 STATIONS.
- 2 TERMINAL STRIP.
- 3 12 GAUGE WIRE.
- 4 PROGRAMMING KEY. MODEL NUMBER: LEIT KEY
- 5 50" STEEL MOUNTING COLUMN. MODEL NUMBER: MCOLXL (LONG)
- 6 FINISH GRADE.
- 7 6-1/2" OF BACKFILL SOIL.
- 8 POURED CONCRETE (3250 PSI) BASE- 2' x 2' x 12" DEEP.
- 9 12 GA. DIRECT BURIAL CONTROL WIRES TO CONTROL VALVES.
- 10 DIG H.D. STAINLESS STEEL VANDAL PROOF COVER WITH DISK LOCK MECHANISM

NOT TO SCALE

	RECOMMENDED: <i>COS</i> 1-16-14 DIVISION MANAGER DATE	CITY OF MORENO VALLEY FINANCIAL & MANAGEMENT SERVICES DEPARTMENT - SPECIAL DISTRICTS DIVISION	STANDARD PLAN
	APPROVED:  1/29/14 PUBLIC WORKS DIRECTOR / DATE CITY ENGINEER	LEIT XRC IRRIGATION CONTROLLER	MVLI-534-0

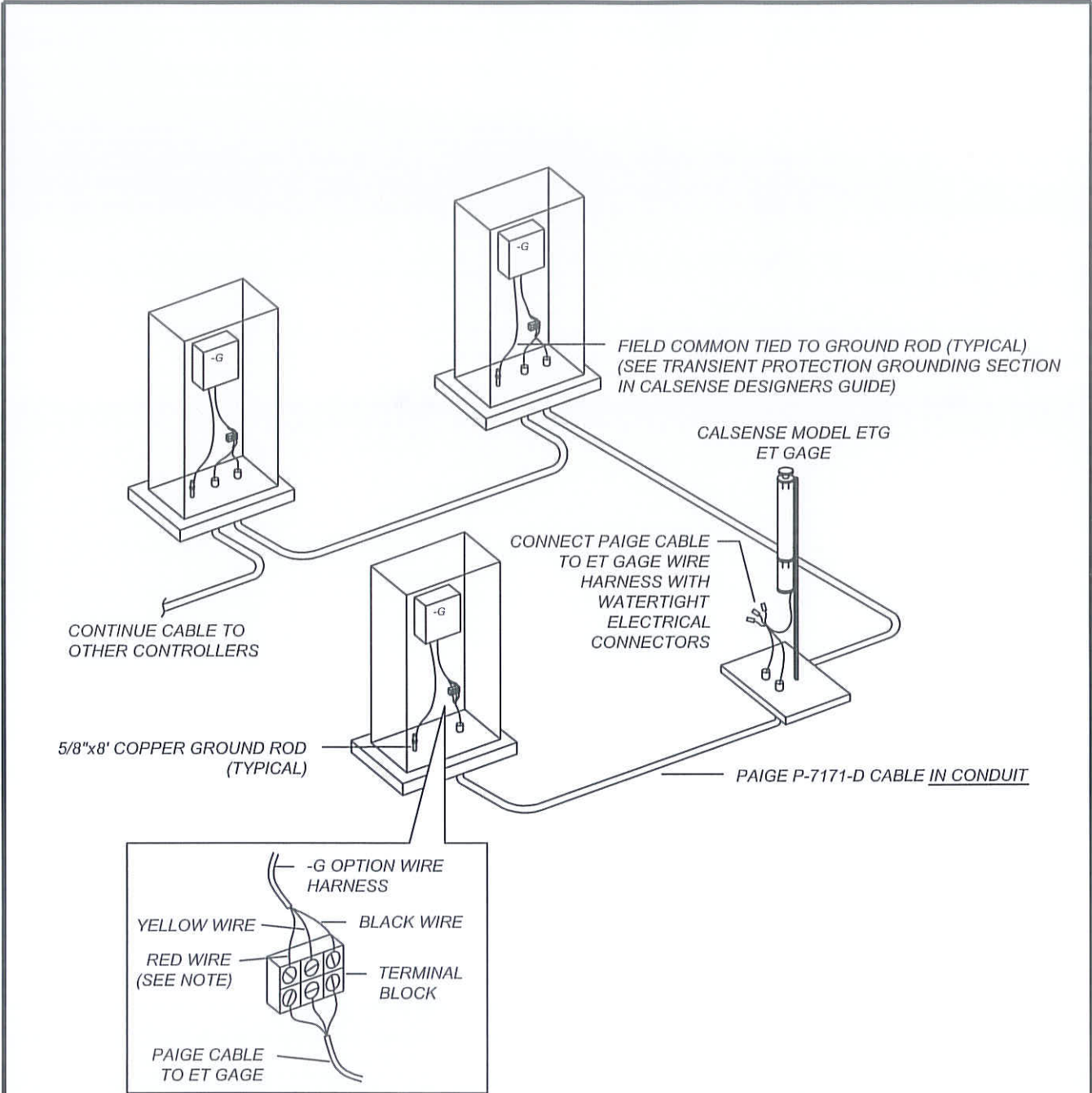

NOTES:

- 1) THERE CAN BE A MAXIMUM OF 12 CONTROLLERS CONNECTED TO ONE ET GAGE WITH A TOTAL LENGTH OF CABLE NOT TO EXCEED 1,000 FEET.
- 2) CONNECT THE RED WIRE FROM THE -G WIRE HARNESS TO ONLY ONE CONTROLLER.

NOT TO SCALE

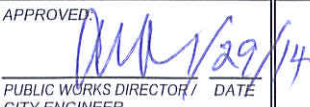
	RECOMMENDED:  / 1/21/14 DIVISION MANAGER / DATE	<h2 style="margin: 0;">CITY OF MORENO VALLEY</h2> <p style="margin: 0;">PARKS AND COMMUNITY SERVICES DEPARTMENT</p>	STANDARD PLAN MVLI-535-0
	APPROVED:  / 1/29/14 PUBLIC WORKS DIRECTOR / DATE CITY ENGINEER	<h3 style="margin: 0;">MULTIPLE CONTROLLERS USING ONE ET GAGE</h3>	

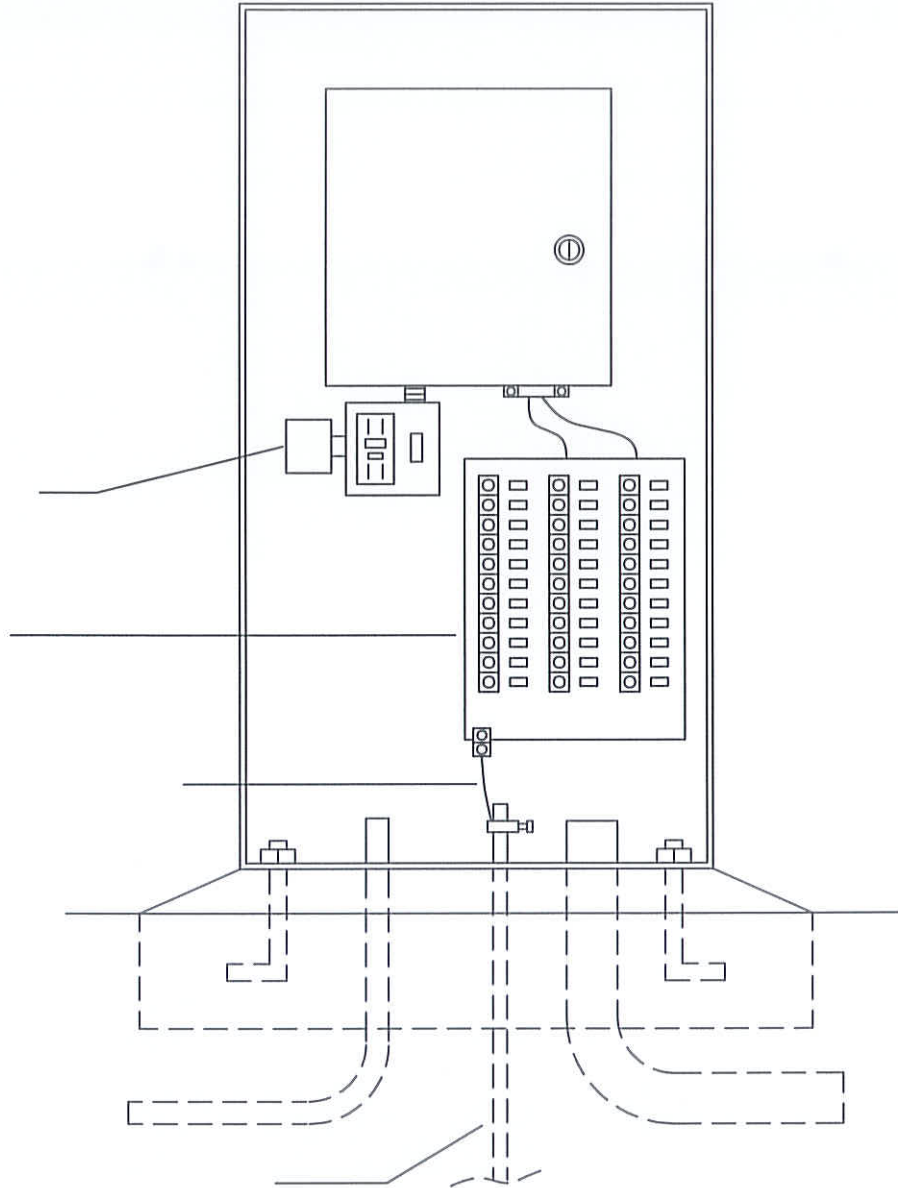

NOT TO SCALE

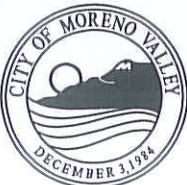

RECOMMENDED:
JA 1/21/14
 DIVISION MANAGER DATE

APPROVED:
MD 1/29/14
 PUBLIC WORKS DIRECTOR/ DATE
 CITY ENGINEER

CITY OF MORENO VALLEY

PARKS AND COMMUNITY SERVICES DEPARTMENT

TYPICAL TRANSIENT PROTECTION INSTALLATION

STANDARD PLAN
MVLI-536-0

SHEET 1 OF 1

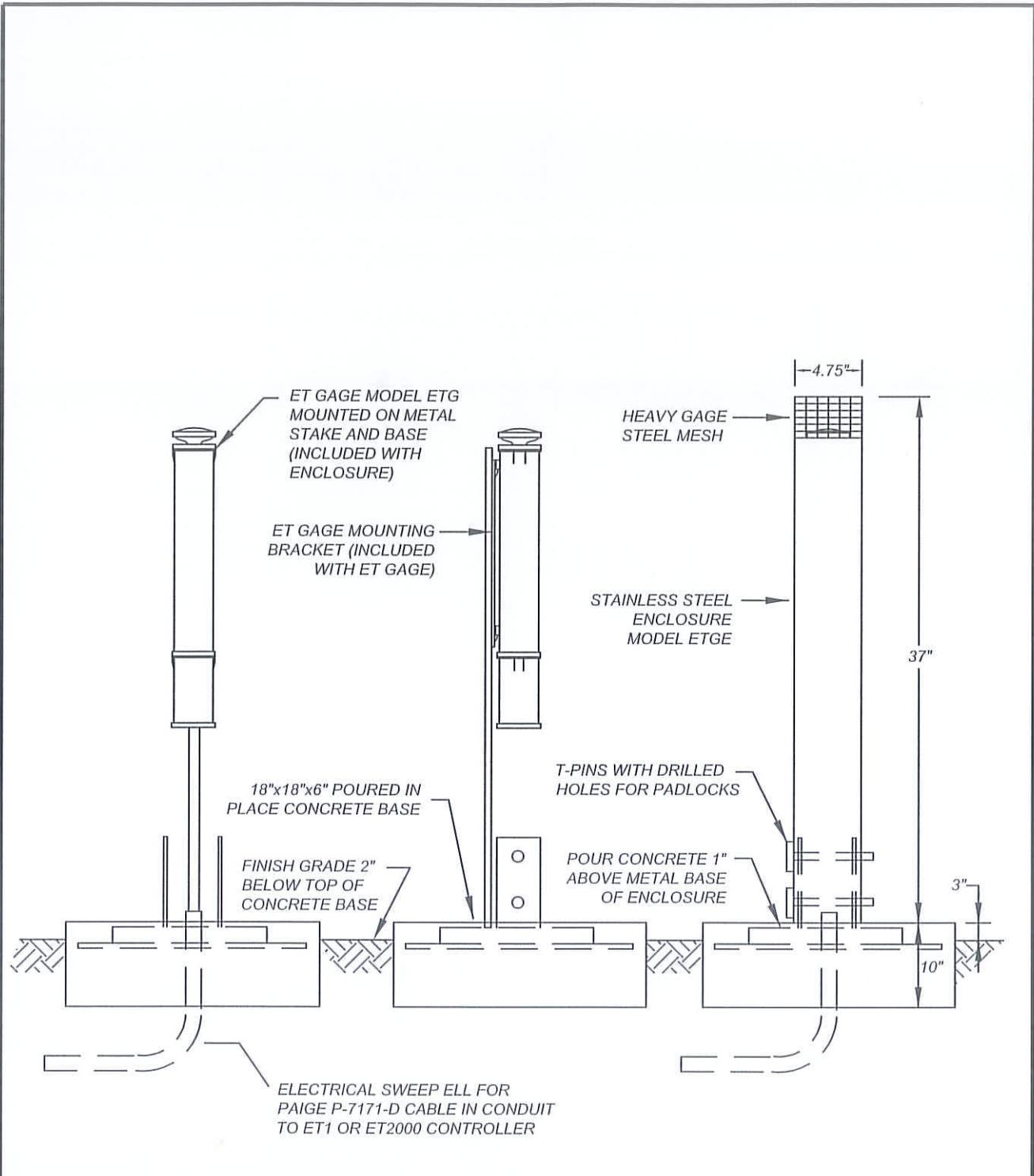

NOT TO SCALE

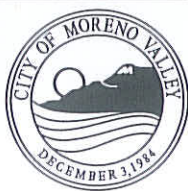
	RECOMMENDED: <i>[Signature]</i> 1/21/14 DIVISION MANAGER DATE	CITY OF MORENO VALLEY PARKS AND COMMUNITY SERVICES DEPARTMENT VANDAL RESISTANT ET GAGE ENCLOSURE	STANDARD PLAN MVLI-537-0
	APPROVED: <i>[Signature]</i> 1/29/14 PUBLIC WORKS DIRECTOR DATE CITY ENGINEER		SHEET 1 OF 1

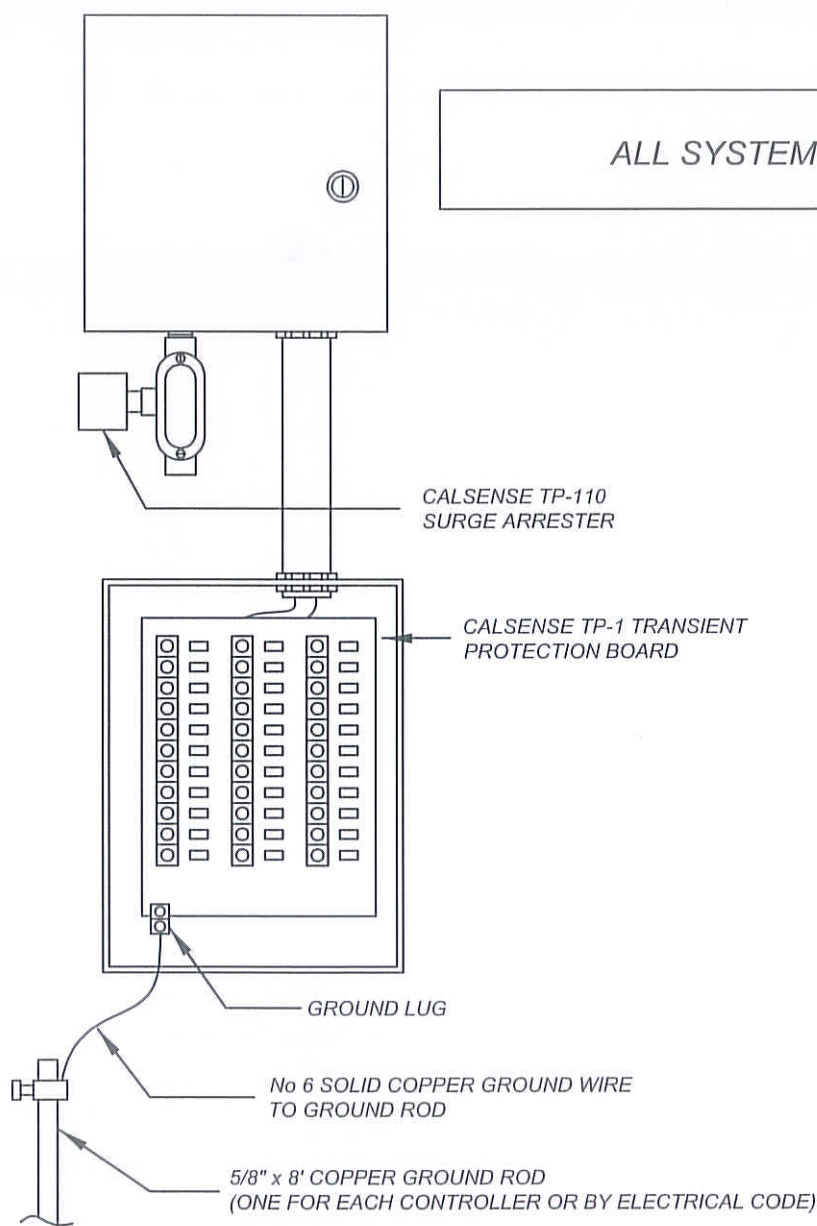

NOT TO SCALE

	RECOMMENDED: <i>[Signature]</i> 11/21/14 DIVISION MANAGER DATE	CITY OF MORENO VALLEY PARKS AND COMMUNITY SERVICES DEPARTMENT	
	APPROVED: <i>[Signature]</i> 1/29/14 PUBLIC WORKS DIRECTOR/ DATE CITY ENGINEER	IRRIGATION CONTROLLER GROUNDING INSTRUCTION	

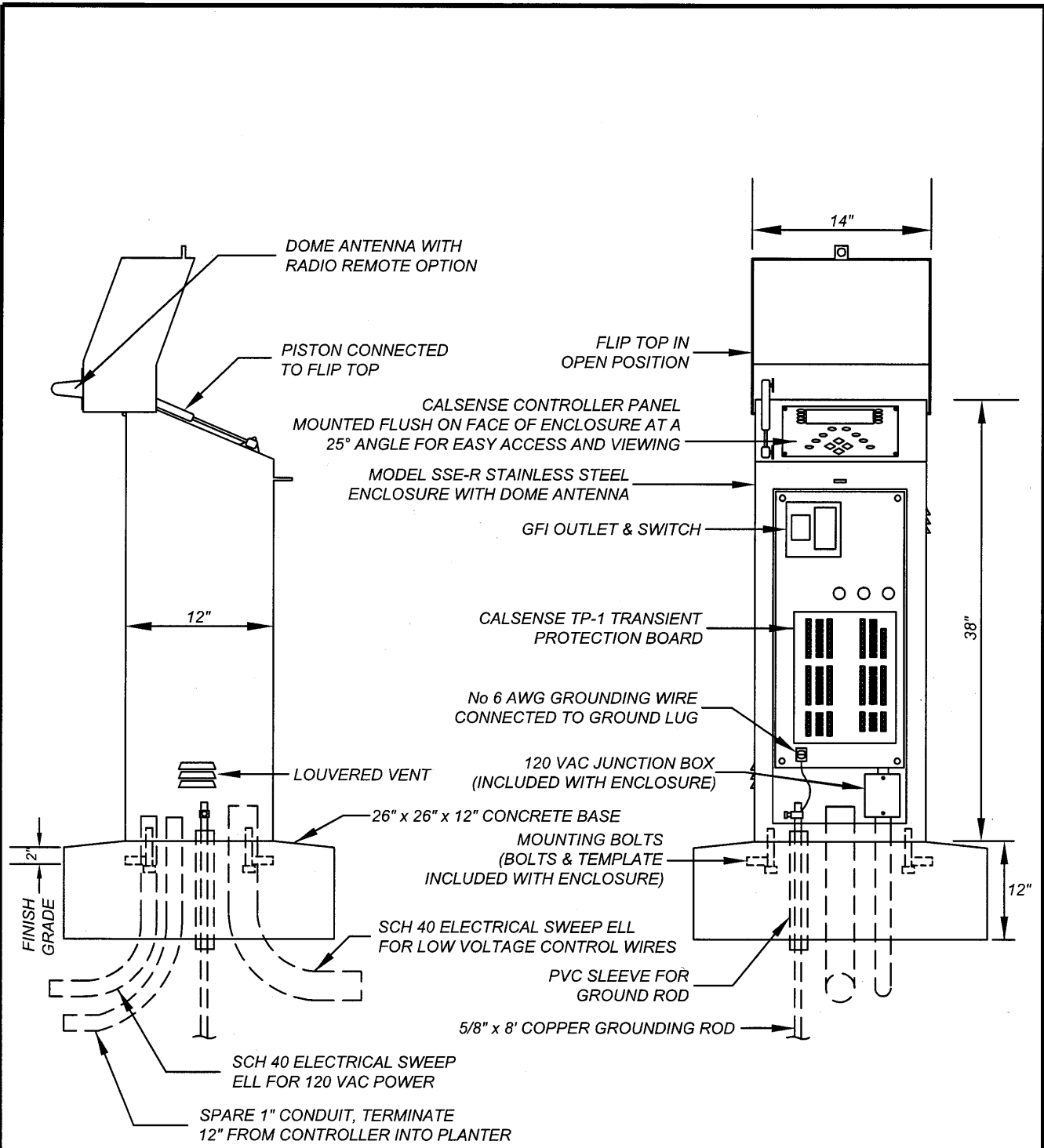

TYPICAL DETAIL, ACTUAL INSTALLATION MAY VARY PER SPECIFIC PRODUCT UTILIZED, AS APPROVED

NOT TO SCALE

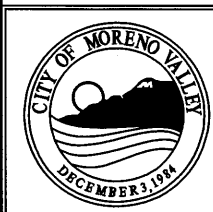

RECOMMENDED:
[Signature] 12/21/16
 DIVISION MANAGER DATE
 APPROVED:
[Signature] 1/20/17
 PUBLIC WORKS DIRECTOR / DATE
 CITY ENGINEER

CITY OF MORENO VALLEY

PARKS AND COMMUNITY SERVICES DEPARTMENT

IRRIGATION CONTROLLER ENCLOSURE INSTALLATION DETAIL

STANDARD PLAN
MVLI-539-0
 SHEET 1 OF 1

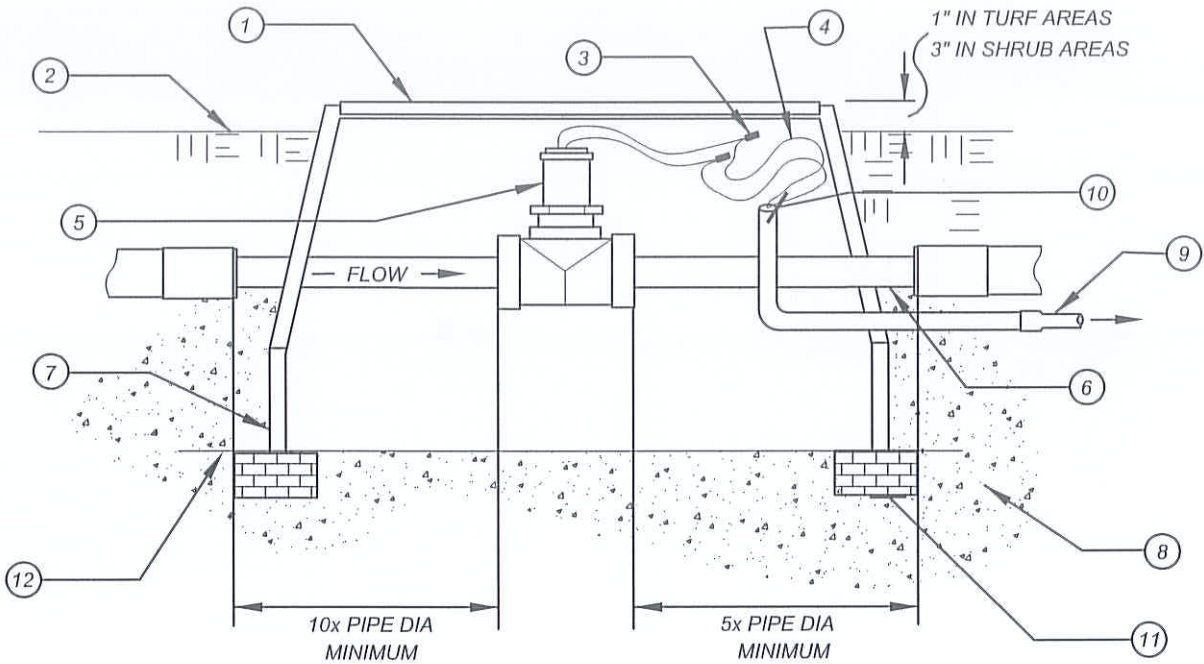

LEGEND:

- ① JUMBO RECTANGULAR PLASTIC VALVE BOX & LOCKING COVER (PER PLAN AS SPECIFIED).
- ② FINISH GRADE
- ③ WATERPROOF CONNECTION (REFER TO STANDARD MVLI-545A-0)
- ④ TWO CONDUCTOR SHIELDED CABLE - ROUTED TO CONTROLLER VIA CONDUIT.
- ⑤ FLOW SENSOR (PER PLAN AS SPECIFIED)
- ⑥ PIPE CHOKE - REDUCE TO NEXT SIZE BELOW MAINLINE PIPE SIZE
- ⑦ VALVE BOX EXTENSION (AS NECESSARY)
- ⑧ PEA GRAVEL DRAIN SUMP - 30" DIA x 6" DEEP MINIMUM
- ⑨ 3/4" E.C. WIRE PATH FROM SENSOR BOX TO MASTER VALVE AND/OR IRRIGATION CONTROLLER
- ⑩ PLUMBERS PUTTY IN HOLE
- ⑪ CONCRETE BRICK, TYPICAL OF 4
- ⑫ 1/4" GALVANIZED WIRE MESH

NOT TO SCALE



RECOMMENDED:
 COS 1.16.14
 DIVISION MANAGER DATE
 APPROVED:
 [Signature] 1/29/14
 PUBLIC WORKS DIRECTOR/ DATE
 CITY ENGINEER

CITY OF MORENO VALLEY
 FINANCIAL & MANAGEMENT SERVICES DEPARTMENT - SPECIAL DISTRICTS DIVISION

**FLOW SENSOR
 ASSEMBLY DETAIL**

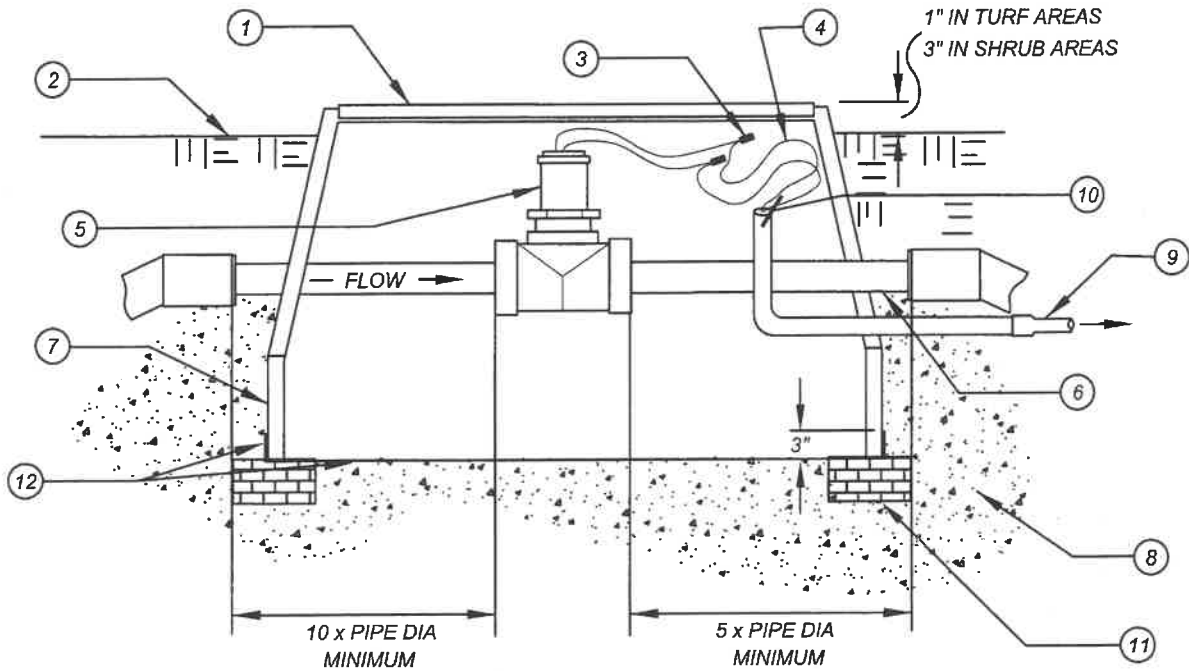

STANDARD PLAN
MVLI-540A-0
 SHEET 1 OF 3



LEGEND:

- ① JUMBO RECTANGULAR PLASTIC VALVE BOX & LOCKING COVER (PER SPECIFICATIONS)
- ② FINISH GRADE
- ③ WATERPROOF CONNECTION (PER SPECIFICATIONS)
- ④ TWO CONDUCTOR SHIELDED CABLE - ROUTED TO CONTROLLER VIA CONDUIT.
- ⑤ FLOW SENSOR (PER PLAN AS SPECIFIED)
- ⑥ PIPE CHOKE - REDUCE TO NEXT SIZE BELOW MAINLINE PIPE SIZE
- ⑦ VALVE BOX EXTENSION (AS NECESSARY)
- ⑧ PEA GRAVEL DRAIN SUMP - 30" DIA x 6" DEEP MINIMUM
- ⑨ 3/4" E.C. WIRE PATH FROM SENSOR BOX TO MASTER VALVE AND/OR IRRIGATION CONTROLLER
- ⑩ DUCT SEAL
- ⑪ CONCRETE BRICK, TYPICAL OF 4
- ⑫ 1/4" STAINLESS STEEL WIRE MESH, TYPE 316

NOT TO SCALE

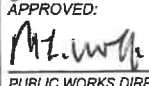

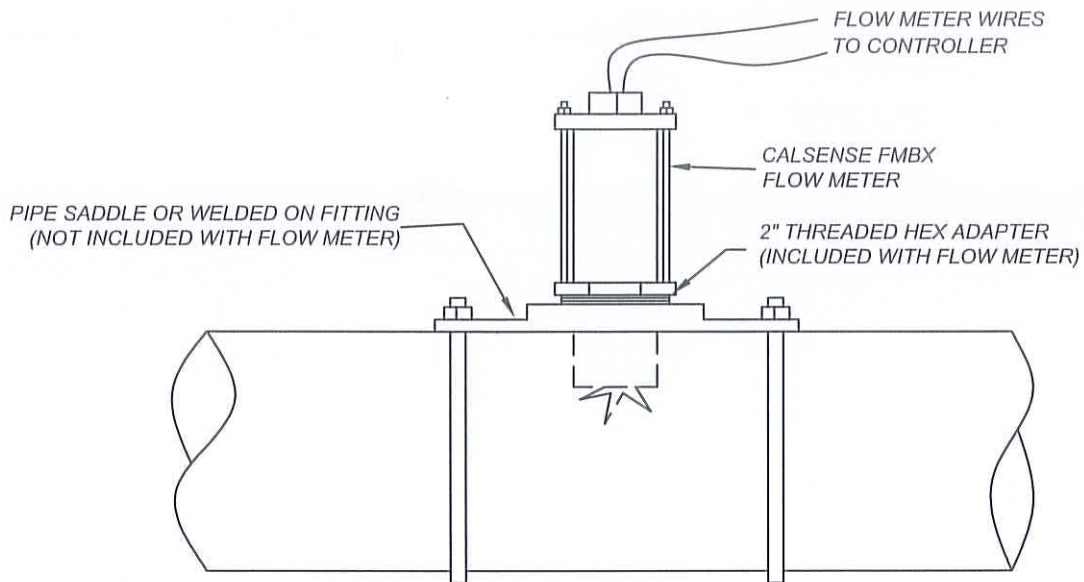
	RECOMMENDED:  6/20/19 DIVISION MANAGER DATE	<h2 style="margin: 0;">CITY OF MORENO VALLEY</h2> <p style="margin: 0;">PARKS AND COMMUNITY SERVICES DEPARTMENT</p>	STANDARD PLAN <h3 style="margin: 0;">MVLI-540B-0</h3>
	APPROVED:  7/30/19 PUBLIC WORKS DIRECTOR / DATE CITY ENGINEER	<h2 style="margin: 0;">FLOW SENSOR ASSEMBLY DETAIL</h2>	



NOTES:

1. FOR USE ON PARKS AND COMMUNITY SERVICES PROJECTS.
2. REQUIRES INSPECTION FROM CALSENSE AND PARKS AND COMMUNITY SERVICES.

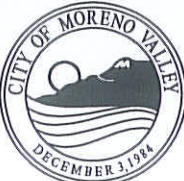
NOT TO SCALE

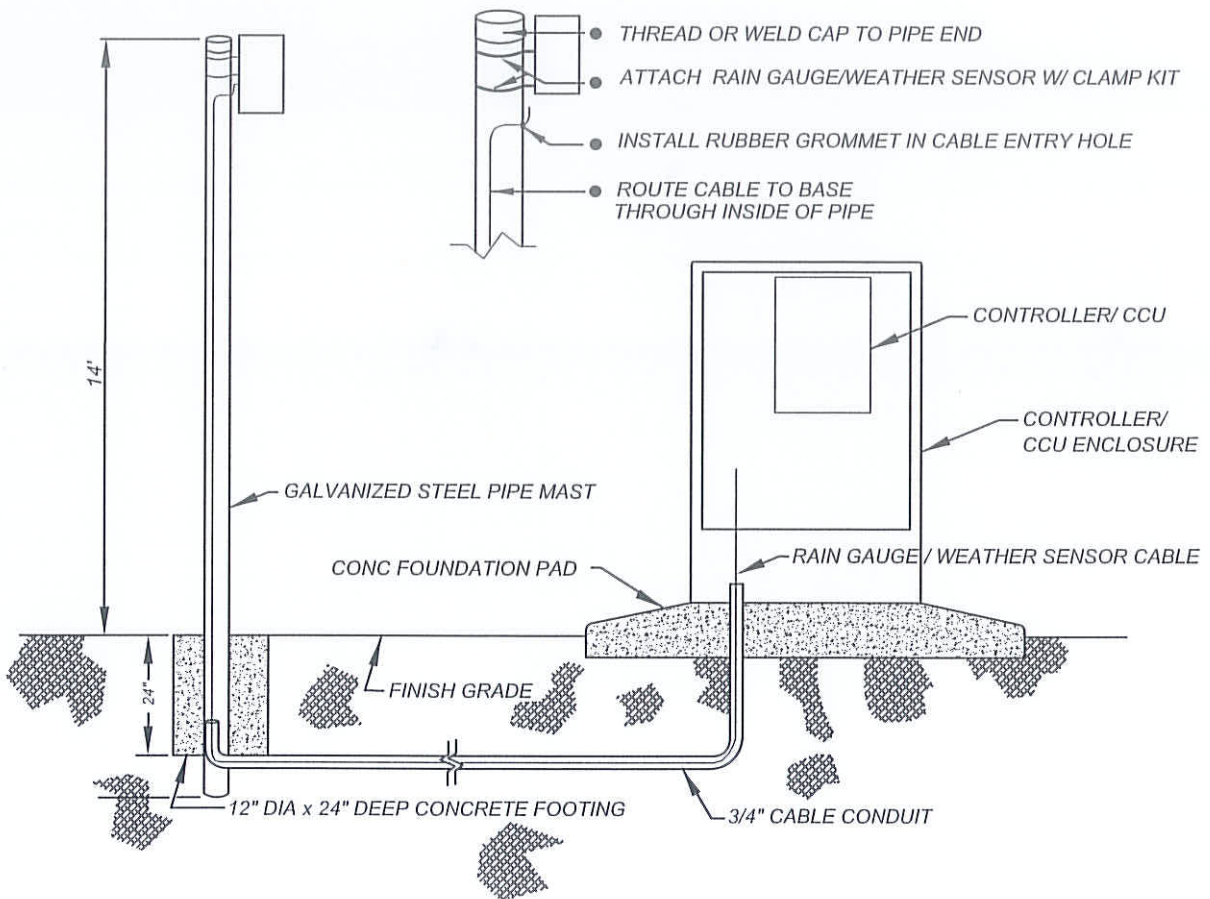

	RECOMMENDED:  1/21/14 DIVISION MANAGER DATE	<h2 style="margin: 0;">CITY OF MORENO VALLEY</h2> <p style="margin: 0;">PARKS AND COMMUNITY SERVICES DEPARTMENT</p>	
	APPROVED:  1/29/14 PUBLIC WORKS DIRECTOR / DATE CITY ENGINEER	<h3 style="margin: 0;">FMBX FLOW METER INSTALLATION</h3>	
			SHEET 3 OF 3



NOTES:

- 1) RAIN GAUGE / WEATHER SENSOR MAST SHALL BE MINIMUM 2" GALVANIZED STEEL PIPE STOCK & FITTINGS.
- 2) RAIN GAUGE / WEATHER SENSOR SHALL BE TYPE SPECIFIED IN PLANS / SPECIFICATIONS.
- 3) WIRE SWEEPS / CONDUIT TO BE SCHEDULE 40 PVC. ALL SWEEPS TO BE 3/4" MIN DIA EXTEND CONDUIT ALONG THE ENTIRE REACH OF LEAD WIRE PATH, ENDING IN CCU ENCLOSURE
- 4) RAIN GAUGE / WEATHER SENSOR CABLE SHALL EXTEND INTO ENCLOSURE 18" PAST END OF SWEEP.

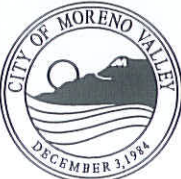
NOT TO SCALE

	RECOMMENDED:  1/21/14 DIVISION MANAGER DATE	CITY OF MORENO VALLEY PARKS AND COMMUNITY SERVICES DEPARTMENT RAIN GAUGE / WEATHER SENSOR INSTALLATION DETAIL	STANDARD PLAN MVLI-541-0
	APPROVED:  1/29/14 PUBLIC WORKS DIRECTOR / DATE CITY ENGINEER		SHEET 1 OF 1

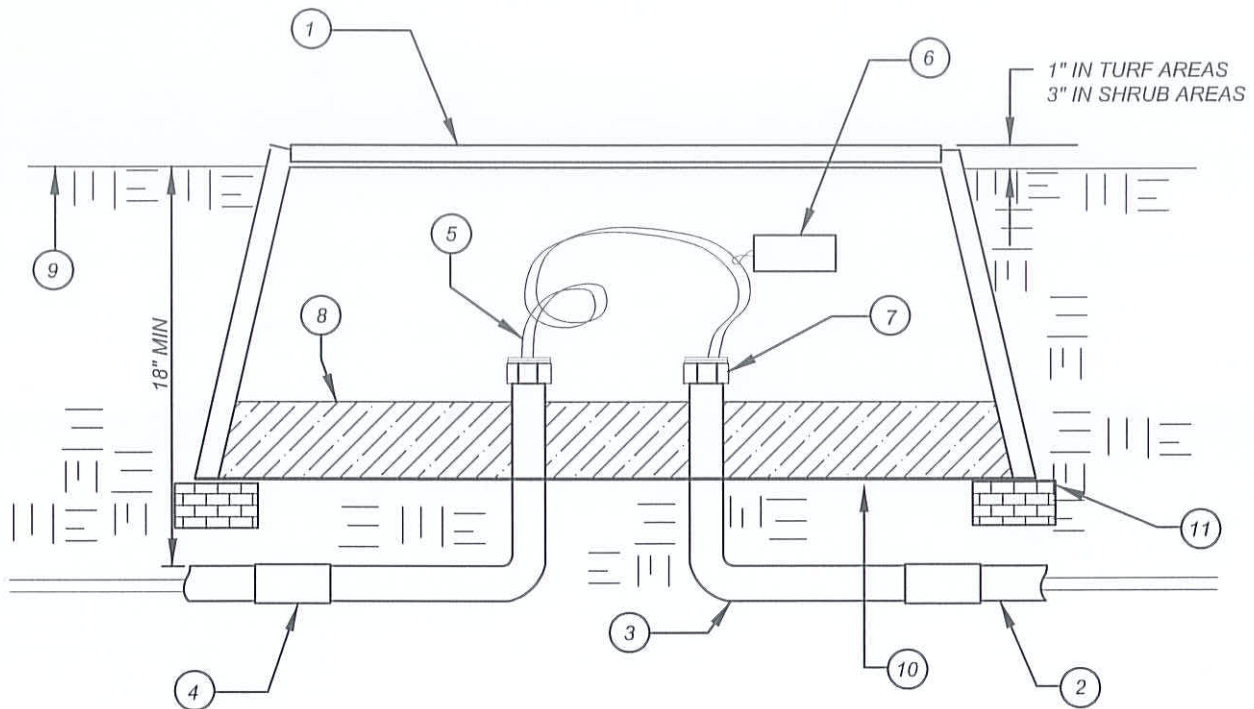

LEGEND:

- ① STANDARD RECTANGULAR VALVE BOX (PER PLAN AS SPECIFIED)
INSTALL @ INTERVALS NOT TO EXCEED 200 FT.
- ② PVC SCH 40 CONDUIT - 1 1/2" NOM OD
- ③ PVC SCH 40, 90 DEG SWEEP ELL (TYP)
- ④ PVC SCH 40, SxS COUPLER (TYP)
- ⑤ POLY PULL ROPE - 500 LB TEST
- INSTALL PULL ROPE ALONG WITH COMMUNICATION CABLE
- LEAVE 2 FT LOOP IN BOX
- ⑥ COMMUNICATION CABLE W/ PERMANENT ID TAG (CHRISTY'S OR EQUAL)
- LEAVE 18" MINIMUM LOOP IN BOX
- COMMUNICATION CABLE TO BE "PE 39"
- ⑦ CONDUIT BUSHING - INSTALL ON PVC SCH 40 MALE ADAPTER
- SEAL ALL CONDUIT ENDS W/ WATER PROOF SILICONE
- SEALER AFTER CABLE/PULL ROPE IS INSTALLED
- ⑧ 3/4" WASHED CRUSHED AGGREGATE - 6" DEPTH
- ⑨ FINISH GRADE
- ⑩ 1/4" GALVANIZED WIRE MESH
- ⑪ CONCRETE BRICK, TYPICAL OF 4

NOT TO SCALE

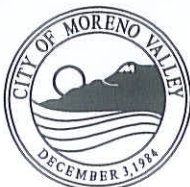

RECOMMENDED:
COS 1/16/14
 DIVISION MANAGER DATE
 APPROVED:
[Signature] 1/29/14
 PUBLIC WORKS DIRECTOR DATE
 CITY ENGINEER

CITY OF MORENO VALLEY
 FINANCIAL & MANAGEMENT SERVICES DEPARTMENT - SPECIAL DISTRICTS DIVISION

**TELEMETRY PULL-BOX
 ASSEMBLY DETAIL**

STANDARD PLAN
MVLI-542A-0
 SHEET 1 OF 2

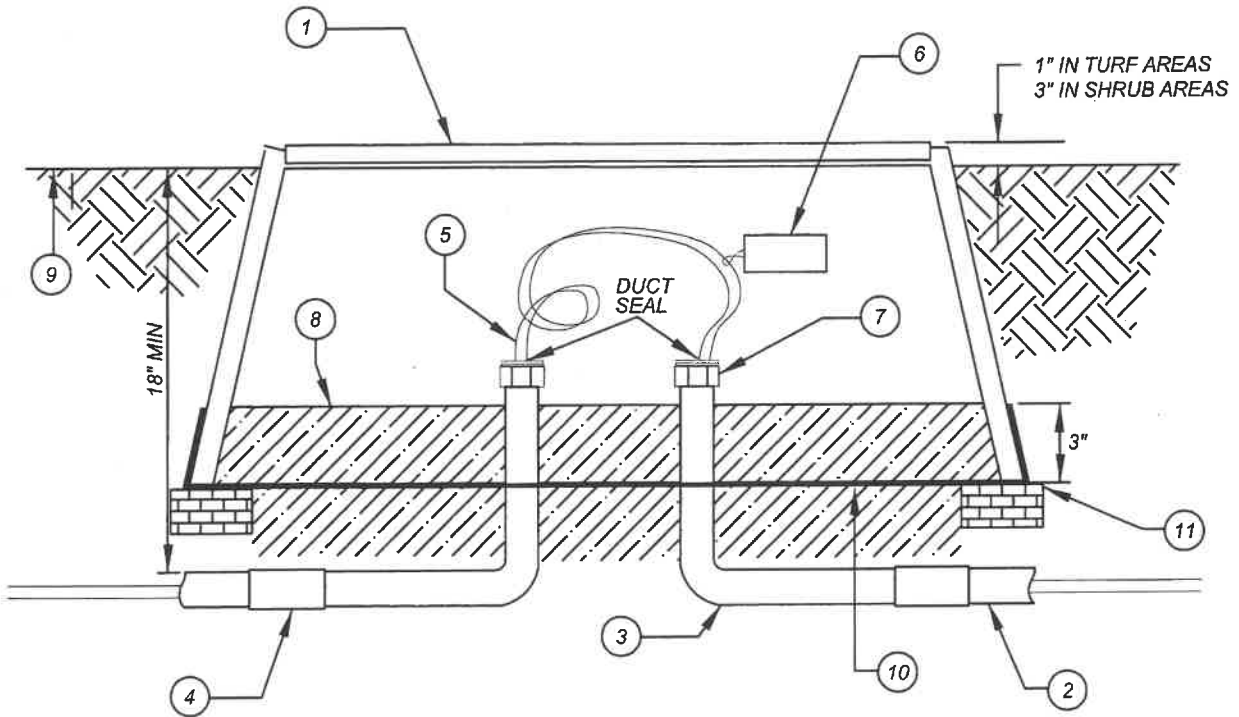

LEGEND:

- ① STANDARD RECTANGULAR VALVE BOX (SPECIFIED)
INSTALL @ INTERVALS NOT TO EXCEED 200 FT
- ② PVC SCH 40 CONDUIT - 1 1/2" NOM OD
- ③ PVC SCH 40, 90 DEG SWEEP ELL (TYP)
- ④ PVC SCH 40, SxS COUPLER (TYP)
- ⑤ POLY PULL ROPE - 500 LB TEST
-INSTALL PULL ROPE ALONG WITH COMMUNICATION CABLE
- LEAVE 2 FT LOOP IN BOX
- ⑥ COMMUNICATION CABLE W/ PERMANENT ID TAG (CHRISTY'S OR EQUAL)
- LEAVE 18" MINIMUM LOOP IN BOX
- COMMUNICATION CABLE TO BE "PE 39"
- ⑦ CONDUIT BUSHING - INSTALL ON PVC SCH 40 MALE ADAPTER
- SEAL ALL CONDUIT ENDS W/ WATER PROOF SILICONE
- SEALER AFTER CABLE/PULL ROPE IS INSTALLED
- ⑧ 3/4" WASHED CRUSHED AGGREGATE - 6" DEPTH
- ⑨ FINISH GRADE
- ⑩ 1/4" STAINLESS STEEL WIRE MESH, TYPE 316
- ⑪ CONCRETE BRICK, TYPICAL OF 4

NOT TO SCALE

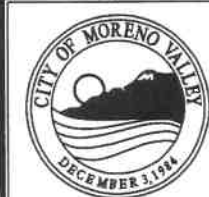

RECOMMENDED:

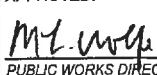
 DIVISION MANAGER
 DATE: 6/20/19

APPROVED:

 PUBLIC WORKS DIRECTOR / DATE
 CITY ENGINEER 7/30/19

CITY OF MORENO VALLEY
 PARKS AND COMMUNITY SERVICES DEPARTMENT

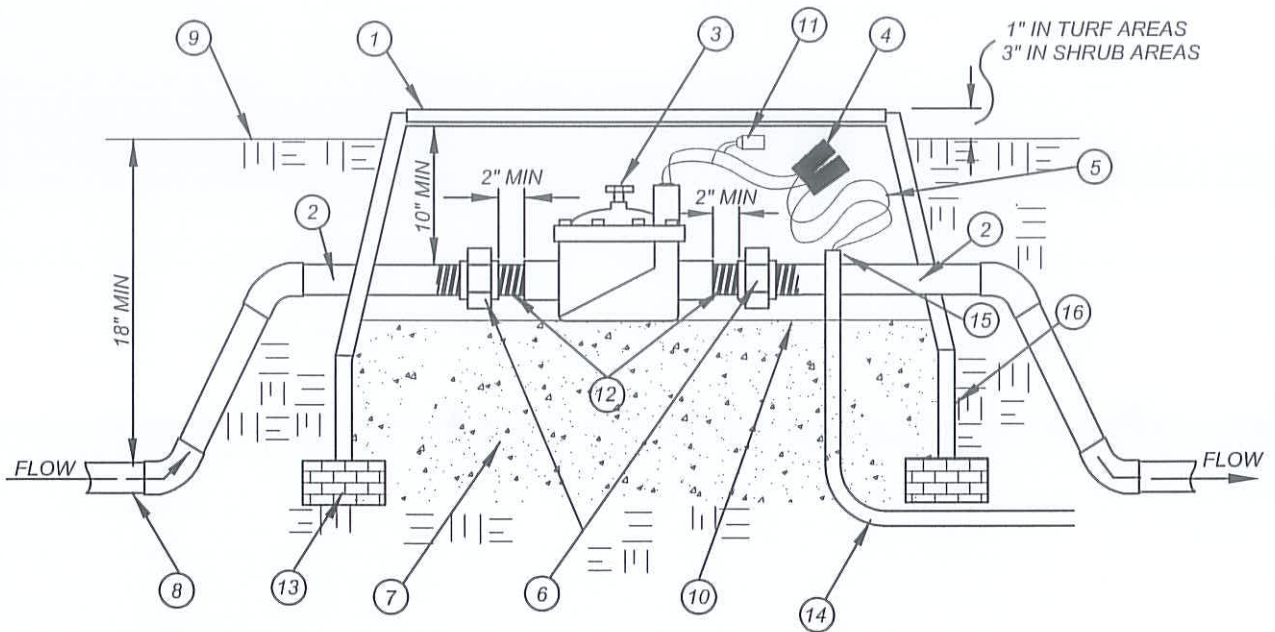
**TELEMETRY PULL-BOX
 ASSEMBLY DETAIL**

STANDARD PLAN
MVLI-542B-0
 SHEET 2 OF 2



1" IN TURF AREAS
3" IN SHRUB AREAS

LEGEND:

- ① JUMBO RECTANGULAR PLASTIC VALVE BOX WITH LOCKING LID (PER PLAN AS SPECIFIED)
- ② SCH 80 TOE NIPPLE ASSEMBLY - USE IN PLACE OF MIPT ADAPTERS (TYP) (REFER TO STD MVLI-544A-0)
- ③ MASTER CONTROL VALVE (PER PLAN AS SPECIFIED)
- ④ WATERPROOF CONNECTION - SPEARS DS-100 OR APPROVED EQUAL. FILL W/ DS-300 SEALANT OR APPROVED EQUAL (REFER TO STANDARD MVLI-545A-0)
- ⑤ PROVIDE 24" MIN EXPANSION LOOP
- ⑥ SCH 80 PVC UNION (FIPT X FIPT)
- ⑦ 3/4" WASHED CRUSHED AGGREGATE - 6" DEPTH
- ⑧ MAINLINE FROM POC/BACKFLOW PREVENTER ASSEMBLY
- ⑨ FINISH GRADE
- ⑩ 1/4" GALVANIZED WIRE MESH SCREEN
- ⑪ CHRISTY ID TAG WITH CONTROLLER NUMBER
- ⑫ SCH 80 CLOSE NIPPLE
- ⑬ CONCRETE BRICK TYP OF 4
- ⑭ 3/4" ELEC CONDUIT TO FLOW SENSOR AND/OR IRRIGATION CONTROLLER
- ⑮ PLUMBERS PUTTY IN HOLE
- ⑯ VALVE BOX EXTENSION (AS NECESSARY)

NOTES:

- 1) INSTALL MASTER VALVE MINIMUM 3 FT DOWNSTREAM OF POC / BACKFLOW ASSEMBLY.
- 2) INSTALL MASTER VALVE MINIMUM 12" FROM STRUCTURES / HARDSCAPE.
- 3) INSTALL THRUST BLOCKS OR BRACE PER SPECIFICATIONS.

NOT TO SCALE

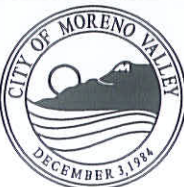

RECOMMENDED:
COS 1.16.14
 DIVISION MANAGER DATE
 APPROVED:
[Signature] 1/29/14
 PUBLIC WORKS DIRECTOR / CITY ENGINEER DATE

CITY OF MORENO VALLEY
 FINANCIAL & MANAGEMENT SERVICES DEPARTMENT - SPECIAL DISTRICTS DIVISION

**MASTER VALVE ASSEMBLY
 DETAIL**

STANDARD PLAN
MVLI-543A-0
 SHEET 1 OF 3

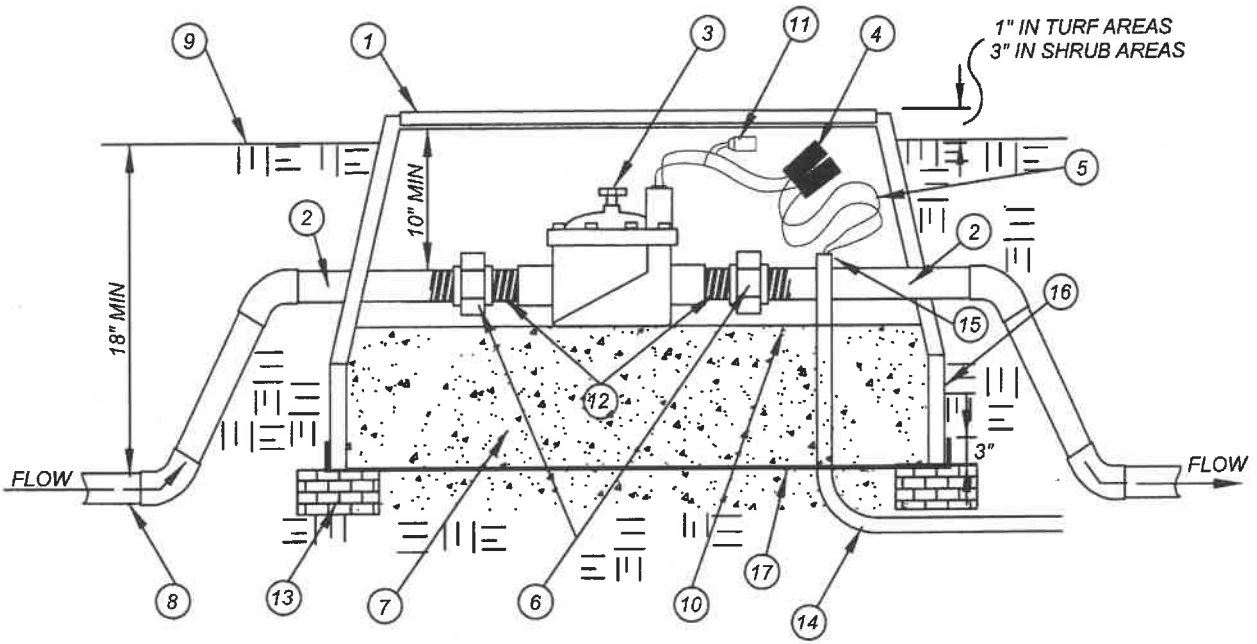

LEGEND:



- ① JUMBO RECTANGULAR PLASTIC VALVE BOX WITH LOCKING LID (PER PLAN AS SPECIFIED)
- ② SCH 80 TOE NIPPLE ASSEMBLY - USE IN PLACE OF MIPT ADAPTERS (TYP) (REFER TO STD MVLI-544B-0)
- ③ MASTER CONTROL VALVE (PER PLAN AS SPECIFIED)
- ④ WATERPROOF CONNECTION (PER SPECIFICATIONS)
- ⑤ PROVIDE 24" MIN EXPANSION LOOP
- ⑥ SCH 80 PVC UNION (FIPT x FIPT)
- ⑦ 3/4" WASHED CRUSHED AGGREGATE - 6" DEPTH
- ⑧ MAINLINE FROM POC/BACKFLOW PREVENTER ASSEMBLY
- ⑨ FINISH GRADE
- ⑩ 1/4" STAINLESS STEEL MESH SCREEN, TYPE 316
- ⑪ CHRISTY ID TAG WITH CONTROLLER NUMBER
- ⑫ SCH 80 CLOSE NIPPLE
- ⑬ CONCRETE BRICK TYP OF 4
- ⑭ 3/4" ELEC CONDUIT TO FLOW SENSOR AND/OR IRRIGATION CONTROLLER
- ⑮ DUCT SEAL
- ⑯ VALVE BOX EXTENSION (AS NECESSARY)
- ⑰ 1/4" GALVANIZED WIRE MESH

NOTES:

- 1) INSTALL MASTER VALVE MINIMUM 3 FT DOWNSTREAM OF POC / BACKFLOW ASSEMBLY.
- 2) INSTALL MASTER VALVE MINIMUM 12" FROM STRUCTURES / HARDSCAPE.
- 3.) INSTALL THRUST BLOCKS OR BRACE PER SPECIFICATIONS.
- 4.) EPOXY COATED DUCTILE IRON FITTINGS REQUIRED ON MAINLINE 4" AND LARGER.

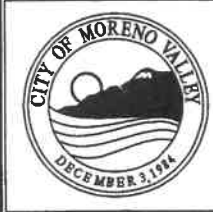
NOT TO SCALE



RECOMMENDED:

 DIVISION MANAGER
 DATE 6/20/19
 APPROVED:

 PUBLIC WORKS DIRECTOR / DATE 7/30/19
 CITY ENGINEER

CITY OF MORENO VALLEY
 PARKS AND COMMUNITY SERVICES DEPARTMENT

**MASTER VALVE ASSEMBLY
 DETAIL**

STANDARD PLAN
MVLI-543B-0
 SHEET 2 OF 3

PIPE SIZING CHART		
F.M. SIZE	UPSTREAM LENGTH	DOWNSTREAM LENGTH
1"	10"	5"
1.25"	12.5"	6.25"
1.5"	15"	7.5"
2"	20"	10"
3"	30"	15"

ALL MODELS OF CALSENSE CONTROLLERS

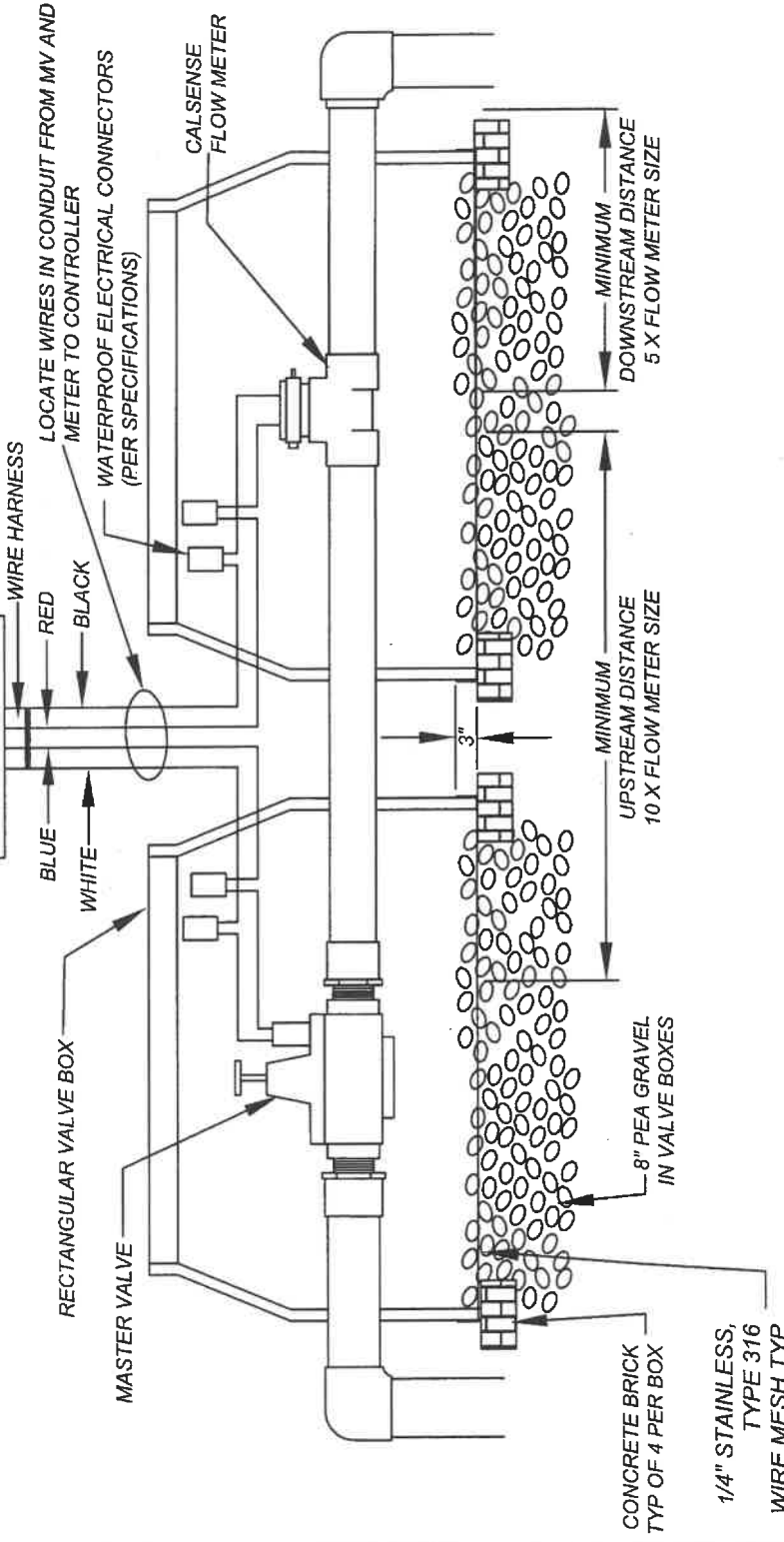

NOTES:

1. FOR USE ON PARKS AND COMMUNITY SERVICES PROJECTS.
2. REQUIRES INSPECTION FROM CALSENSE AND PARKS AND COMMUNITY SERVICES.

NOT TO SCALE

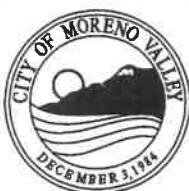

RECOMMENDED: *[Signature]* 6/20/19
 DIVISION MANAGER DATE
 APPROVED: *[Signature]* 7/30/19
 PUBLIC WORKS DIRECTOR / DATE
 CITY ENGINEER

CITY OF MORENO VALLEY
 PARKS AND COMMUNITY SERVICES DEPARTMENT

MASTER VALVE AND FLOW METER INSTALLATION

STANDARD PLAN
MVLI-543C-0
 SHEET 3 OF 3

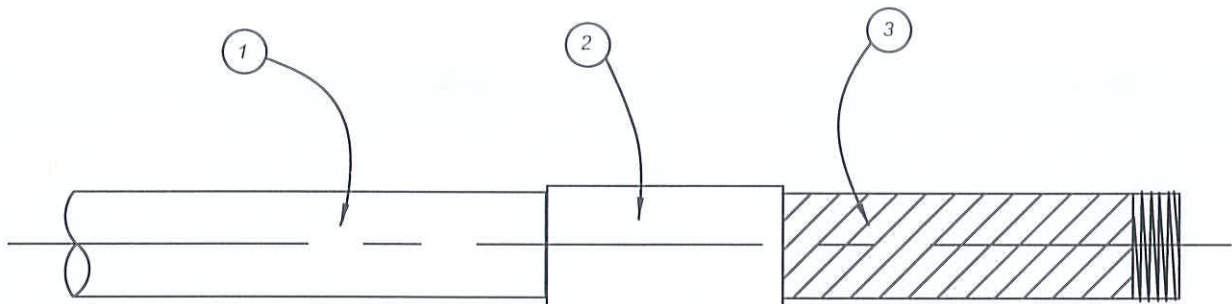

LEGEND:

- ① PVC MAIN / LATERAL LINE PIPE
- ② SCH 80 PVC COUPLING SLIP x SLIP
- ③ SCH 80 PVC NIPPLE - THREADED ONE END
 - 6" MIN LENGTH
 - CUT THREADS ONLY - NO MOLDED NIPPLES

NOTES:

1) USE TOE NIPPLE ASSEMBLY IN PLACE OF MIPT ADAPTERS

NOT TO SCALE

	RECOMMENDED: <div style="display: flex; justify-content: space-between;"> <div style="text-align: center;"> </div> <div style="text-align: center;"> 1.16.14 <small>DATE</small> </div> </div>	<h2 style="margin: 0;">CITY OF MORENO VALLEY</h2> <p style="margin: 0;">FINANCIAL & MANAGEMENT SERVICES DEPARTMENT - SPECIAL DISTRICTS DIVISION</p>	
	APPROVED: <div style="display: flex; justify-content: space-between;"> <div style="text-align: center;"> </div> <div style="text-align: center;"> 1/29/14 <small>DATE</small> </div> </div>	<h3 style="margin: 0;">TOE NIPPLE ASSEMBLY</h3>	
			SHEET 1 OF 2

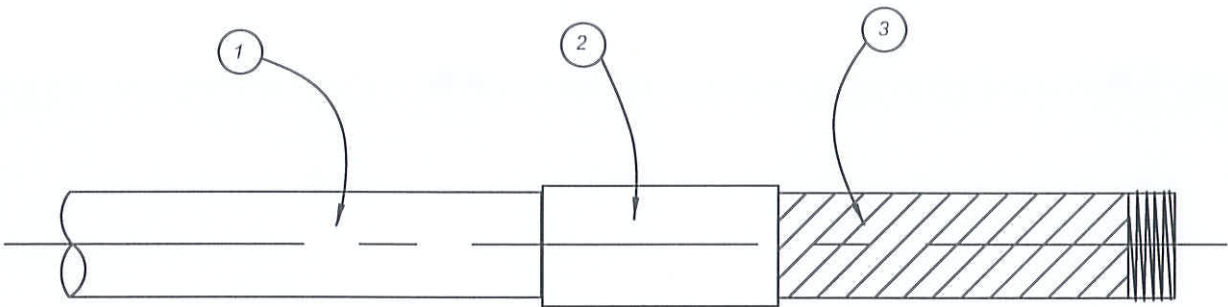



LEGEND:

- ① PVC MAIN / LATERAL LINE PIPE
- ② SCH 80 PVC COUPLING SLIP x SLIP
- ③ SCH 80 PVC NIPPLE - THREADED ONE END
 - 6" MIN LENGTH
 - CUT THREADS ONLY - NO MOLDED NIPPLES

NOTES:

- 1.) USE TOE NIPPLE ASSEMBLY IN PLACE OF MIPT ADAPTERS.
- 2.) 4" PIPE AND LARGER REQUIRES EPOXY COATED DUCTILE IRON FITTINGS.

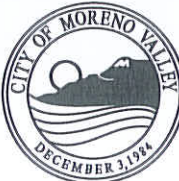
NOT TO SCALE

	RECOMMENDED:  1/21/14 DIVISION MANAGER DATE	<h2 style="margin: 0;">CITY OF MORENO VALLEY</h2> <p style="margin: 0;">PARKS AND COMMUNITY SERVICES DEPARTMENT</p>	STANDARD PLAN <h3 style="margin: 0;">MVLI-544B-0</h3>
	APPROVED:  1/29/14 PUBLIC WORKS DIRECTOR / DATE CITY ENGINEER	<h2 style="margin: 0;">TOE NIPPLE ASSEMBLY</h2>	SHEET 2 OF 2

STEP 1

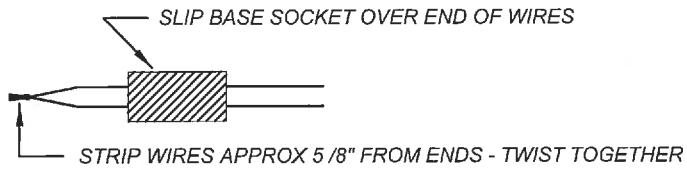

STEP 2

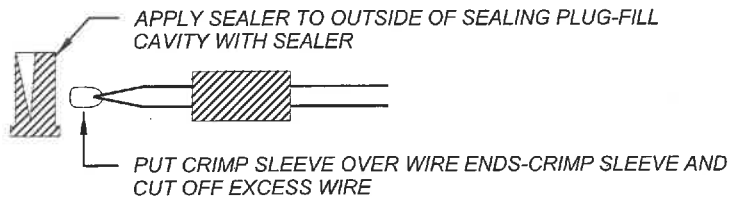

STEP 3

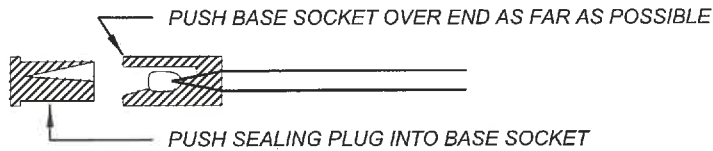

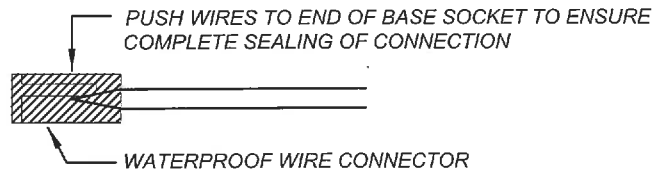

STEP 4



NOTES:

- 1.) DO NOT USE PREFILLED CONNECTORS ON FLOW SENSORS OR MASTER VALVES.
- 2.) CONNECTORS SHALL BE 600V RATED.

NOT TO SCALE

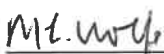
	RECOMMENDED:  7/22/19 DIVISION MANAGER / DATE	CITY OF MORENO VALLEY PUBLIC WORKS DEPARTMENT - SPECIAL DISTRICTS DIVISION	STANDARD PLAN
	APPROVED:  7/31/19 PUBLIC WORKS DIRECTOR / DATE CITY ENGINEER		IRRIGATION WIRE CONNECTOR
			SHEET 1 OF 3

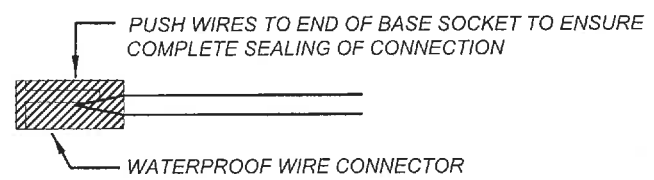
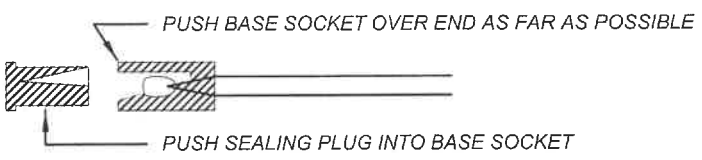
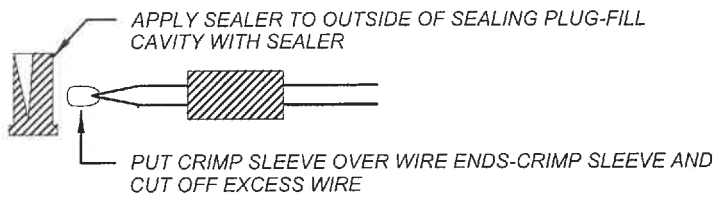
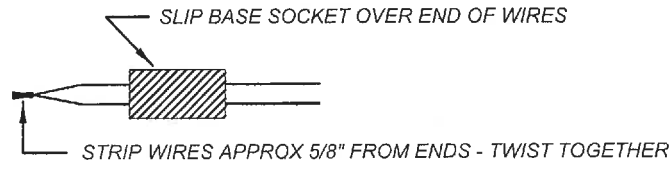

INSTALLATION INSTRUCTIONS:

- 1.) TURN OFF POWER BEFORE INSTALLING OR REMOVING CONNECTOR
- 2.) STRIP WIRES 5/8"
- 3.) PRE-TWISTING UNNECESSARY. HOLD STRIPPED WIRES TOGETHER WITH ENDS EVEN. LEAD STRANDED WIRES SLIGHTLY. ALIGN ANY FRAYED STRANDS OR CONDUCTORS
- 4.) FIRMLY PUSH WIRES INTO TWIST-ON CONNECTOR AND SCREW CONNECTOR CLOCKWISE ONTO WIRE UNTIL TIGHT
- 5.) INSERT THE SPLICE TO THE BOTTOM OF THE SEALANT FILLED TUBE
- 6.) POSITION WIRES INTO WIRE CHANNELS AND WIPE ANY SEALANT AROUND OPENING AND CONDUCTORS
- 7.) CLOSE LID ENSURING LATCH IS SECURED

NOTES:

- 1.) CONNECTORS SHALL BE 600V RATED.
- 2.) PREFILLED CONNECTORS ARE PREFILLED RAINBIRD OR RAINBIRD DBRY20*.

* DO NOT USE PRE-FILLED CONNECTORS ON FLOW SENSORS, TIP BUCKET, WIND GAUGE, OR MASTER VALVE

NOT TO SCALE

	RECOMMENDED:  DIVISION MANAGER	 DATE	<h2 style="margin: 0;">CITY OF MORENO VALLEY</h2> <p style="margin: 0;">PARKS AND COMMUNITY SERVICES DEPARTMENT</p>	STANDARD PLAN <h3 style="margin: 0;">MVLI-545B-0</h3>
	APPROVED:  PUBLIC WORKS DIRECTOR / CITY ENGINEER	 DATE	<h2 style="margin: 0;">IRRIGATION WIRE CONNECTOR</h2>	SHEET 2 OF 3

IRRIGATION CONTROL WIRE NOTES:

U.F. TYPE, U.L. APPROVED, AWG MINIMUM NUMBER 12 SOLID STRAND COPPER WIRE WITH MINIMUM 4/64" PVC COATING, 600 VOLT, 75 C., SUITABLE FOR DIRECT BURIAL. 'COMMON' WIRE TO BE WHITE COATED, U.F. TYPE, U.L. APPROVED, AWG NUMBER 12 SOLID STRAND COPPER WIRE WITH MINIMUM 4/64" PVC COATING, 600 VOLT, 75 C., SUITABLE FOR DIRECT BURIAL. WHERE WIRE RUNS EXCEED 1000' FEET, THE 'COMMON' WIRE SHALL BE AWG NUMBER 10 SOLID STRAND COPPER WIRE WITH MINIMUM 4/64" PVC COATING, 600 VOLT, 75 C., SUITABLE FOR DIRECT BURIAL. AN EXTRA CONTROL WIRE (MINIMUM OF ONE) SHALL BE INSTALLED FOR EVERY SIX (6) REMOTE CONTROL VALVES TO THE END OF THE MAINLINE. ONE EXTRA (1) COMMON WIRE (GREEN) SHALL BE RUN FROM EACH CONTROLLER(S) TO THE END OF THE MAINLINE. EACH EXTRA WIRE SHALL BE FROM THE CONTROLLER(S), EXTENDING TO THE LAST VALVE OR END OF MAINLINE AND LOOPED INTO EACH VALVE BOX.





EACH MASTER VALVES, FLOW METER, ET GAUGE, TIPPING BUCKET AND WIND SENSOR SHALL HAVE WIRING ENCASED IN CONDUIT, FROM THE CONTROLLER TO THE VALVE OR METER. THE IRRIGATION WIRE IS TO BE LOCATED DIRECTLY TO THE SIDE OF THE MAINLINE AND TAPED AT INTERVALS OF 8'. WHERE ADDITIONAL (FUTURE) WIRE QUANTITIES ON THE PLAN CONFLICT WITH THESE SPECIFICATIONS, THE GREATER AMOUNT WILL PREVAIL. WIRE COLORS SHALL BE AS LISTED BELOW:

CONTROLLER 'A', 'B', AND 'C':

- a. 'A' PILOT = BLACK
- b. 'B' PILOT = GREEN
- c. 'C' PILOT = RED
- d. 'A' COMMON = WHITE WITH BLACK STRIPE
- e. 'B' COMMON = WHITE WITH GREEN STRIPE
- f. 'C' COMMON = WHITE WITH RED STRIPE
- g. 'A' PILOT SPARE = BLACK WITH YELLOW STRIPE
- h. 'B' PILOT SPARE = GREEN WITH YELLOW STRIPE
- i. 'C' PILOT SPARE = RED WITH YELLOW STRIPE
- j. 'A' COMMON SPARE = ORANGE WITH BLACK STRIPE
- k. 'B' COMMON SPARE = ORANGE WITH GREEN STRIPE
- l. 'C' COMMON SPARE = ORANGE WITH RED STRIPE

MASTER VALVE #1 = PURPLE
 MASTER VALVE #2 = GRAY
 FLOW SENSOR #1 = BLUE
 FLOW SENSOR #2 = PINK
 FERTILIZER INJECTOR = TAN
 PUMP RELAY = YELLOW

NOT TO SCALE

	RECOMMENDED:  DIVISION MANAGER	 DATE	<h2 style="margin: 0;">CITY OF MORENO VALLEY</h2> <p style="margin: 0;">PARKS AND COMMUNITY SERVICES DEPARTMENT</p>
	APPROVED:  PUBLIC WORKS DIRECTOR / CITY ENGINEER	 DATE	<h3 style="margin: 0;">IRRIGATION CONTROL WIRE NOTES</h3>

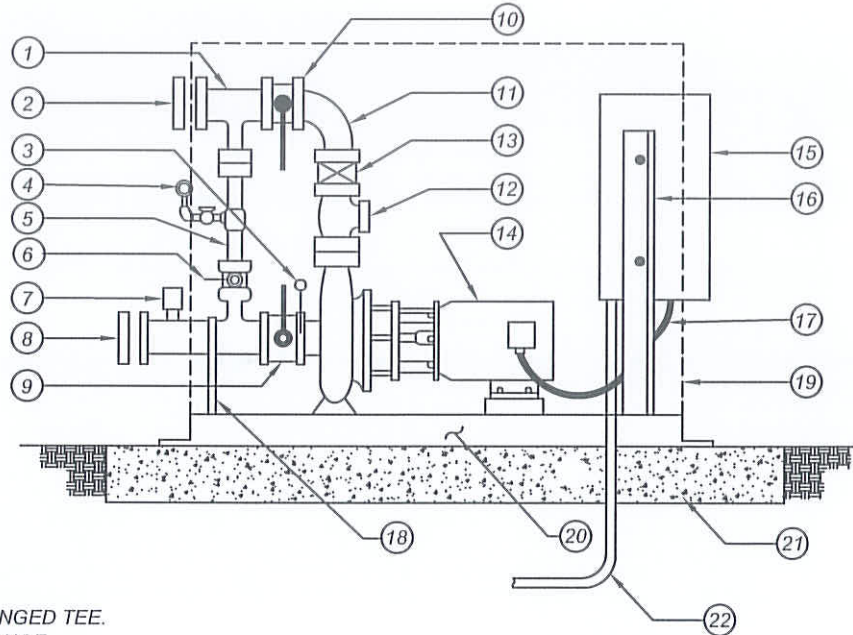

LEGEND:

- ① DISCHARGE FLANGED TEE.
- ② COMPANION FLANGE.
- ③ PRESSURE GAUGE.
- ④ PRESSURE GAUGE.
- ⑤ BYPASS - 2" DIA MIN.
- ⑥ BUTTERFLY VALVE
- ⑦ FLOW SWITCH TO BE INSTALLED IN SECTION HEADER WIRED TO PUMP PANEL.
- ⑧ COMPANION FLANGE.
- ⑨ BUTTERFLY VALVE.
- ⑩ BUTTERFLY VALVE.
- ⑪ FLANGED 90 COMBINATION PRESSURE REGULATING AND NON-SLAM CHECK VALVE.
- ⑫ BAILEY No 400 ACP OR CLA-VAL No 91A.
- ⑬ FLANGED CONCENTRIC REDUCER.
- ⑭ PUMP AND MOTOR.
- ⑮ CONTROLLER (3 PHASE, 230 VOLT)
- ⑯ CONTROLLER SUPPORT.
- ⑰ SEALTITE CONDUIT
- ⑱ SUPPORT LEG.
- ⑲ 36" x 42" x 20" SHEET METAL ENCLOSURE FOR EXTERIOR PUMP INSTALLATION.
- ⑳ GALVANIZED STEEL SKID, WITH 4 9/16" HOLES.
- ㉑ PRE-CAST CONCRETE PAD BY MFG.
- ㉒ RIGID STEEL CONDUIT TO POWER SOURCE

NOTES:

- 1) ENCLOSURE IS REQUIRED SUBJECT TO CITY APPROVAL.
- 2) CONTRACTOR TO VERIFY AVAILABLE VOLTAGE COMPATIBLE WITH MOTOR SPECIFICATIONS.

NOT TO SCALE

	RECOMMENDED: <i>CO5</i> 1.16.14 DIVISION MANAGER DATE	<h2 style="margin: 0;">CITY OF MORENO VALLEY</h2> <p style="margin: 0;">FINANCIAL & MANAGEMENT SERVICES DEPARTMENT - SPECIAL DISTRICTS DIVISION</p>	STANDARD PLAN MVLI-546-0
	APPROVED: 1/29/14 PUBLIC WORKS DIRECTOR / DATE CITY ENGINEER	<h3 style="margin: 0;">IRRIGATION BOOSTER PUMP DETAIL</h3>	SHEET 1 OF 1

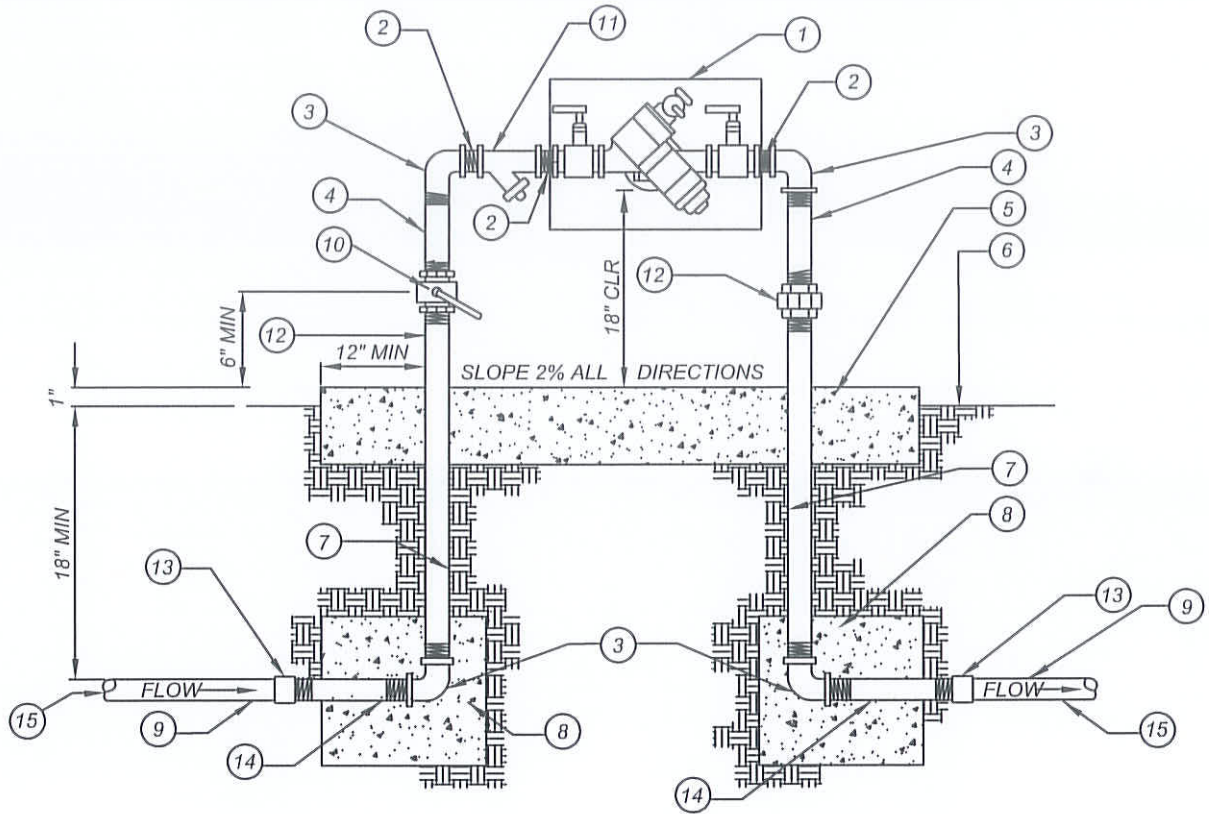

LEGEND:

- 1 BACKFLOW PREVENTER ASSEMBLY
- 2 BRASS CLOSE NIPPLE
- 3 BRASS 90 ELL-TYPICAL (4) PLACES
- 4 BRASS NIPPLE
- 5 6" THICK CONCRETE PAD (SEE PAD SCHEDULE)
SLOPE TO DRAIN AT MINIMUM 2%
- 6 FINISH GRADE
- 7 BRASS NIPPLE
- 8 12" x 12" x 12" CONCRETE THRUST BLOCKS - TYPICAL (2) PLACES
- 9 SCHEDULE 80 TOE NIPPLE ASSEMBLY - TYPICAL (2) PLACES (REFER TO STANDARD MVLI-544A-0)
- 10 LINE SIZED BRASS FULL PORT LOCKING BALL VALVE
- 11 BRASS WYE STRAINER WITH 60 MESH SCREEN AS SPECIFIED
- 12 BRASS UNION (OR PRESSURE REGULATOR WITH UNION IF REQUIRED)
- 13 BRASS COUPLING
- 14 BRASS NIPPLE - LENGTH AS NECESSARY TO EXTEND PAST CONCRETE PAD
- 15 PVC MAIN LINE

PAD SCHEDULE

RP DEVICE SIZE	WIDTH	LENGTH
2 1/2"	30"	66"
3"-4"	36"	78"

NOTES:

- 1) EQUIPMENT TO BE INSTALLED AT A MINIMUM OF 24" FROM ANY STRUCTURES OR HARDSCAPING.
- 2) WHEN UNIT IS NEXT TO A STRUCTURE (I.E. WALL, BUILDING, ETC.) MOUNT TEST COCKS ON OPEN OR NON-STRUCTURE SIDE.
- 3) REDUCED PRESSURE DEVICE MUST BE SAME SIZE AS WATER METER/SERVICE LINE PER EMWD.
- 4) IF PRESSURE REGULATING VALVE IS REQUIRED, INSTALL ON DOWNSTREAM LEG OF BACKFLOW PREVENTER.

NOT TO SCALE

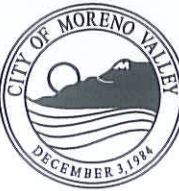
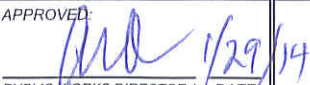
	RECOMMENDED: <i>COS</i> 1-16-14 DIVISION MANAGER DATE	<h2 style="margin: 0;">CITY OF MORENO VALLEY</h2> <p style="margin: 0;">FINANCIAL & MANAGEMENT SERVICES DEPARTMENT - SPECIAL DISTRICTS DIVISION</p>	STANDARD PLAN MVLI-547A-0
	APPROVED:  PUBLIC WORKS DIRECTOR / DATE CITY ENGINEER	<h3 style="margin: 0;">REDUCED PRESSURE BACKFLOW PREVENTER</h3>	SHEET 1 OF 2

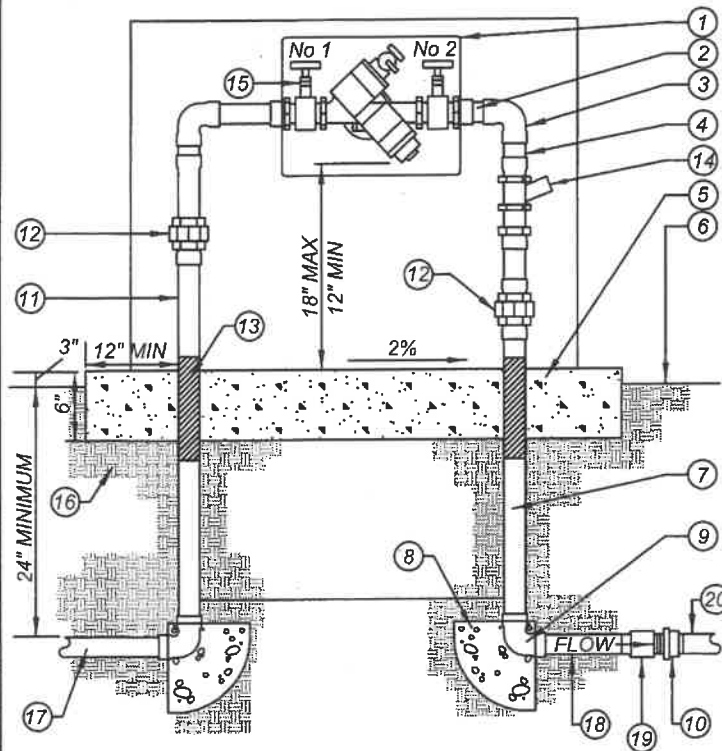

LEGEND:

- ① BACKFLOW PREVENTER ASSEMBLY, PRE-ASSEMBLED
- ② BRASS OR TYPE K COPPER NIPPLE-TYPICAL
- ③ BRASS OR TYPE K COPPER 90 ELL-TYPICAL
- ④ BRASS OR TYPE K COPPER NIPPLE
- ⑤ 6" THICK CONCRETE PAD (3250 PSI) SLOPE TO DRAIN AT MINIMUM 2%
- ⑥ FINISH GRADE
- ⑦ BRASS OR TYPE K COPPER NIPPLE
- ⑧ 1 CU FT CONCRETE THRUST BLOCKS - TYPICAL (2) PLACES
- ⑨ BRASS OR TYPE K COPPER 90 ELL
- ⑩ SCHEDULE 80 PVC MALE ADAPTER
- ⑪ FROM WATER SOURCE
- ⑫ BRASS UNION WITH ADAPTERS
- ⑬ 10 MIL POLYETHYLENE TAPE, 1.5 TIMES WRAP
- ⑭ WYE STRAINER PER SPECIFICATION
- ⑮ SHUT OFF VALVE (TYPE VARIES)
- ⑯ 90% COMPACTED SUBGRADE
- ⑰ TYPE K COPPER SERVICE
- ⑱ 8" LONG BRASS OR TYPE K COPPER NIPPLE
- ⑲ BRASS OR TYPE K COPPER FEMALE ADAPTER
- ⑳ TYPE K COPPER (AS REQUIRED) PRESSURE SUPPLY LINE

NOTES:

- 1) BACKFLOW PREVENTER ASSEMBLY SHALL BE APPROVED AND TESTED UPON INSTALLATION BY A EMWD APPROVED CERTIFIED BACKFLOW DEVICE TESTER. CONTRACTOR SHALL PROVIDE THE ENGINEER AND CITY WITH WRITTEN RESULTS COMPLETED BY A CERTIFIED BACKFLOW TESTER.
- 2) PRIOR TO BACKFLOW PREVENTER'S ACCEPTANCE BY THE ENGINEER, ALL METAL IN CONTACT WITH CONCRETE SHALL BE POLYETHYLENE WRAPPED USING 2" WIDE PLASTIC BACKED ADHESIVE TAPE MIN. 10 MILS. THICK 1/2" OVERLAP.
- 3) CONCRETE PAD TO BE 2" ABOVE GRADE. CONCRETE PAD SHALL BE 3,250 PSI, 8" THICK, 24" WIDE (MIN), + 3' ON HINGED SIDE.
- 4) FACTORY ASSEMBLED REDUCED PRESSURE PRINCIPLE ASSEMBLY SHALL BE INCLUDED IN THE EDITION OF THE 'APPROVED FOR SERVICE ISOLATION IN CALIFORNIA PUBLIC WATER SYSTEMS' ISSUED BY THE STATE OF CALIFORNIA DEPARTMENT.
- 5) PRESSURE REGULATOR MAY BE INSTALLED UPSTREAM OF THE BACKFLOW PREVENTER ASSEMBLY WHEN WATER PRESSURE EXCEEDS BACKFLOW PREVENTER ASSEMBLY RATING.
- 6) COMBINATION OF WYE STRAINER AND REGULATOR, WHEN REQUIRED, SHALL BE LOCATED UPSTREAM OF BACKFLOW DEVICE.
- 7) PROTECTIVE ENCLOSURE FOR BACKFLOW PREVENTER ASSEMBLY SHALL BE USED SIZE TO FIT.
- 8) LOCATE PREVENTER ASSEMBLY AS APPROVED BY PARKS AND COMMUNITY SERVICES.
- 9) ALL RISERS, ELBOWS AND UNDERGROUND PIPING SHALL BE BRASS OR TYPE 'K' COPPER. BRASS UNIONS ARE ACCEPTABLE. ALL PIPING SHALL BE POLY SLEEVED. EPOXY OR POLLYESTER DIPPED DUCTILE IRON REQUIRED 4" AND LARGER UNITS.
- 10) BACKFLOW DEVICES REQUIRE A FROST GUARD BLANKET.
- 11) PAINT DOMESTIC BACKFLOW - GREEN, IRRIGATION - BLUE, RECLAIMED - PURPLE

PAD SCHEDULE

RP DEVICE SIZE	WIDTH	MIN LENGTH
2 1/2"	30"	66"
3"-4"	36"	78"

NOT TO SCALE



RECOMMENDED: *[Signature]* 6/20/19
 DIVISION MANAGER DATE
 APPROVED: *[Signature]* 7/30/19
 PUBLIC WORKS DIRECTOR / DATE
 CITY ENGINEER

CITY OF MORENO VALLEY
 PARKS AND COMMUNITY SERVICES DEPARTMENT

BACK FLOW PREVENTER

STANDARD PLAN
MVLI-547B-1

SHEET 2 OF 2

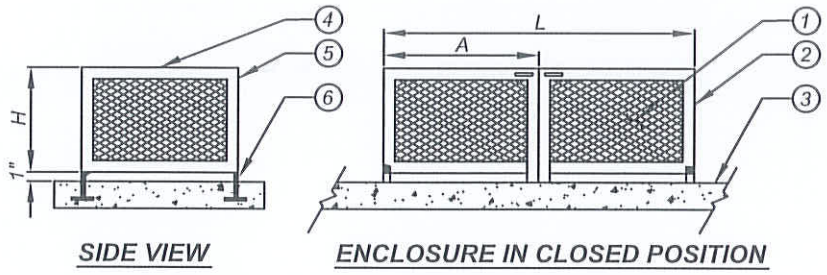
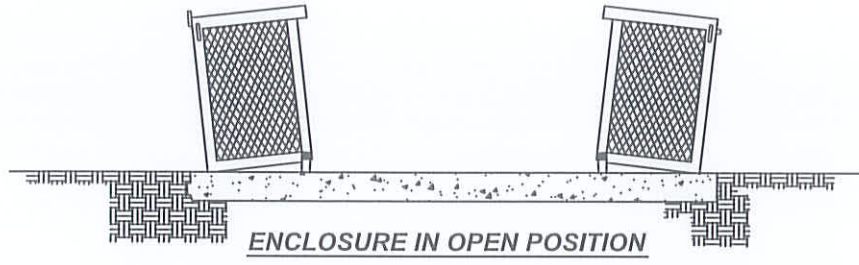

RP DEVICE SIZE	W	L	H	A
2 1/2"	24"	60"	36"	30"
3"-4"	30"	72"	42"	36"

LEGEND:

- ① 1 1/2"- No 9 EXPANDED METAL
- ② 1 1/2" x 1 1/2" x 3/16" ANGLE FRAME
- ③ CONCRETE PAD (SEE STANDARD MVLI-547A-0)
- ④ HASP FOR PAD LOCK
- ⑤ LIFTING HANDLE
- ⑥ HINGE PLATE

NOTES:

- 1) FINISH TO BE TWO COATS OF SEMI-GLOSS GREEN ENAMEL PAINT, OR AS SPECIFIED ON PLANS.
- 2) FOR UNITS 2" AND UNDER USE SINGLE SWING HINGE MODEL.
- 3) IT IS THE RESPONSIBILITY OF THE CONTRACTOR TO ENSURE THAT THE BACKFLOW PREVENTER ASSEMBLY FITS WITHIN SPECIFIED ENCLOSURE. ANY DISCREPANCY SHALL BE REPORTED TO SPECIAL DISTRICTS IMMEDIATELY.

NOT TO SCALE

	RECOMMENDED: <i>COS</i> 1-16-14 <small>DIVISION MANAGER DATE</small>	<h2 style="margin: 0;">CITY OF MORENO VALLEY</h2> <p style="margin: 0;">FINANCIAL & MANAGEMENT SERVICES DEPARTMENT - SPECIAL DISTRICTS DIVISION</p>	<small>STANDARD PLAN</small> MVLI-548A-0
	APPROVED: <i>[Signature]</i> 1/29/14 <small>PUBLIC WORKS DIRECTOR / DATE</small> <small>CITY ENGINEER</small>	<h3 style="margin: 0;">BACKFLOW PREVENTER ENCLOSURE</h3>	<small>SHEET 1 OF 3</small>

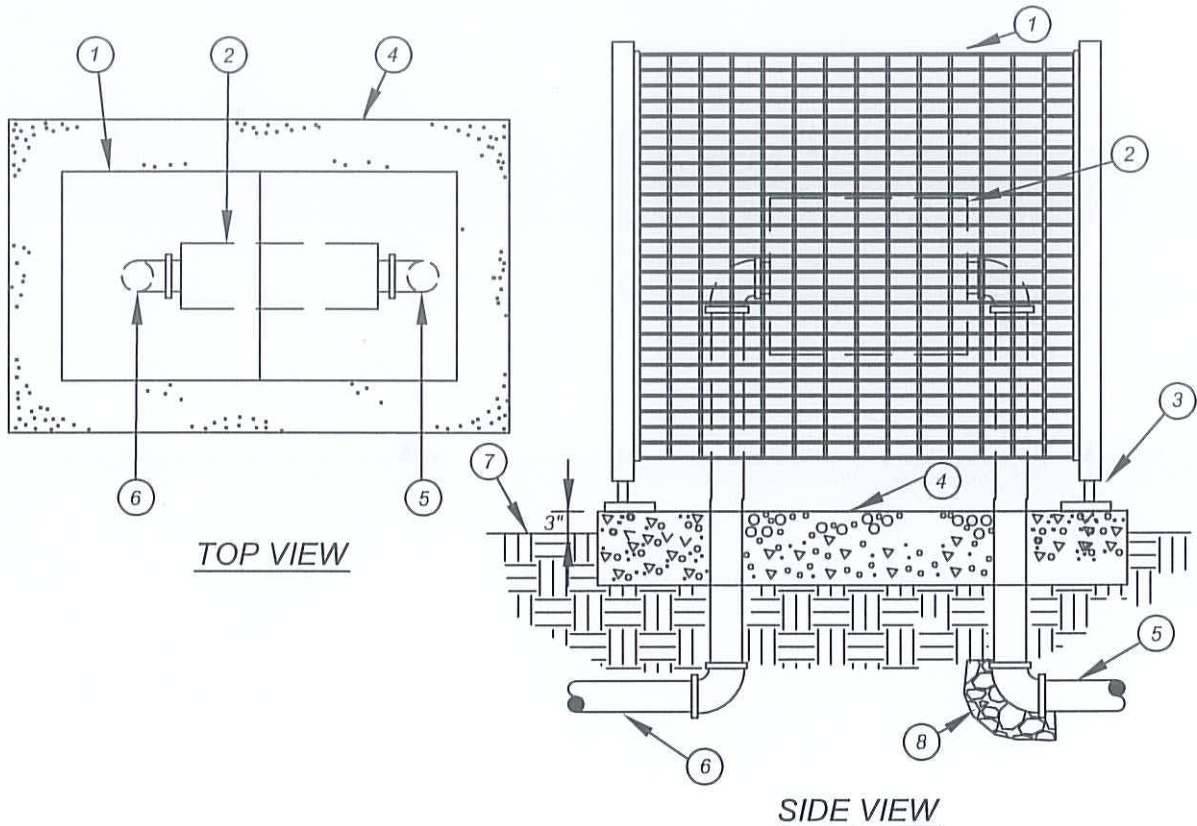



LEGEND:

- ① SMOOTH TOUCH STAINLESS STEEL. BACKFLOW COVER WITH VANDAL PROOF LOCKING DEVICE
- ② BACKFLOW PREVENTER
- ③ ANCHOR ROD (TYPICAL)
- ④ 3250 PSI POURED CONCRETE BASE - 9" MINIMUM THICKNESS THAT EXTENDS 6" BEYOND OUTSIDE DIMENSIONS OF ENCLOSURE AND 3' ON THE HINGED SIDE(S) OF THE ENCLOSURE.
- ⑤ WATER SERVICE INLET PIPING
- ⑥ WATER SERVICE OUTLET PIPING
- ⑦ FINISH GRADE
- ⑧ THRUST BLOCK, TYPICAL OF 2

NOTES:

1. USE OF EXPANDED METAL REQUIRES SANDBLAST AND POWDERCOATING. (COLOR DETERMINED BY SPECIFICATIONS. MUST BE PRE-APPROVED BY PARKS AND COMMUNITY SERVICES.)
2. UNIT REQUIRES SUBMITTAL AND APPROVAL OF SHOP DRAWINGS.

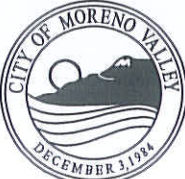
NOT TO SCALE

	RECOMMENDED:  1/21/14 DIVISION MANAGER DATE	<h2 style="margin: 0;">CITY OF MORENO VALLEY</h2> <p style="margin: 0;">PARKS AND COMMUNITY SERVICES DEPARTMENT</p>	STANDARD PLAN MVLI-548B-0
	APPROVED:  1/29/14 PUBLIC WORKS DIRECTOR / DATE CITY ENGINEER	<h2 style="margin: 0;">SINGLE BACKFLOW COVER</h2>	

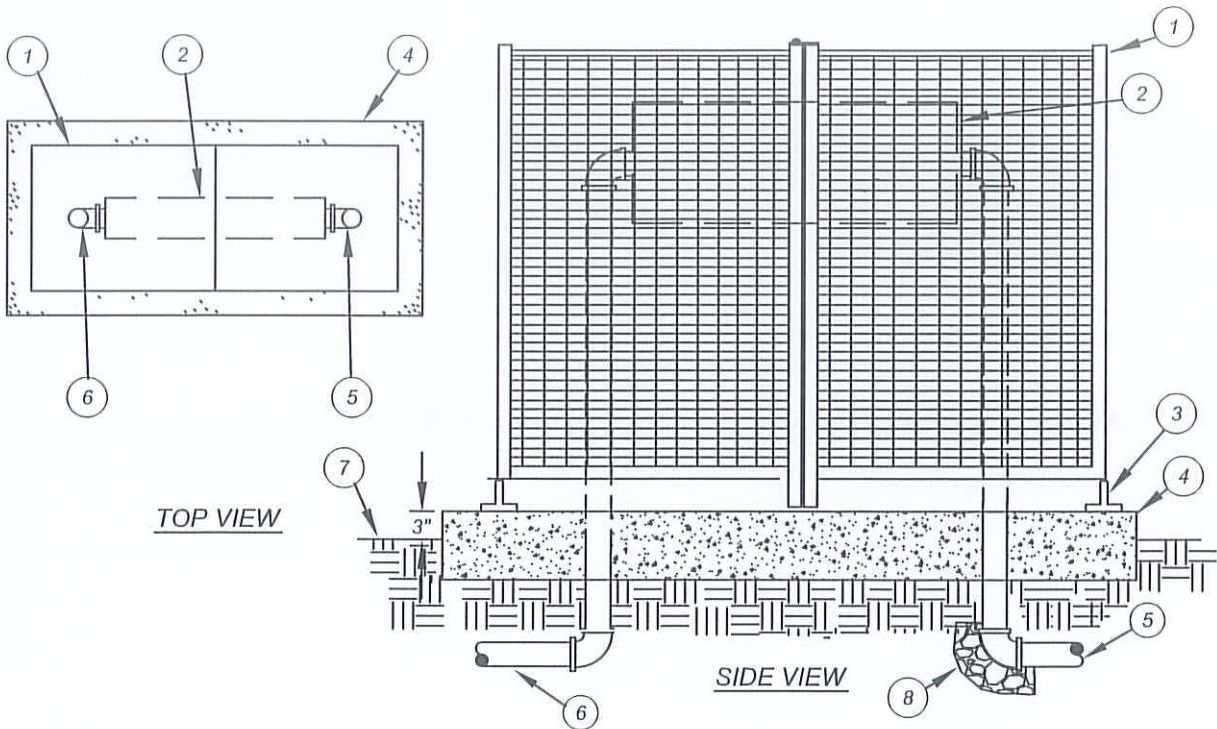

LEGEND:

- ① SMOOTH TOUCH STAINLESS STEEL. BACKFLOW COVER WITH VANDAL PROOF LOCKING DEVICE
- ② BACKFLOW PREVENTER
- ③ ANCHOR ROD (TYPICAL)
- ④ 3250 PSI POURED CONCRETE BASE - 12" MINIMUM THICKNESS THAT EXTENDS 6" BEYOND OUTSIDE DIMENSIONS OF ENCLOSURE AND 3' ON THE HINGED SIDES OF THE ENCLOSURE.
- ⑤ WATER SERVICE INLET PIPING
- ⑥ WATER SERVICE OUTLET PIPING
- ⑦ FINISH GRADE
- ⑧ THRUST BLOCK, TYPICAL OF 2

NOTES:

1. USE OF EXPANDED METAL REQUIRES SANDBLAST AND POWDERCOATING (COLOR DETERMINED BY SPECIFICATIONS). MUST BE PRE-APPROVED BY PARKS AND COMMUNITY SERVICES.
2. UNIT REQUIRES SUBMITTAL AND APPROVAL OF SHOP DRAWINGS.

NOT TO SCALE

	RECOMMENDED: DIVISION MANAGER DATE 4/21/14	<h2 style="margin: 0;">CITY OF MORENO VALLEY</h2> <p style="margin: 0;">PARKS AND COMMUNITY SERVICES DEPARTMENT</p>	STANDARD PLAN MVLI-548C-0
	APPROVED: PUBLIC WORKS DIRECTOR / DATE 4/29/14 CITY ENGINEER	<h3 style="margin: 0;">DOUBLE BACKFLOW COVER</h3>	

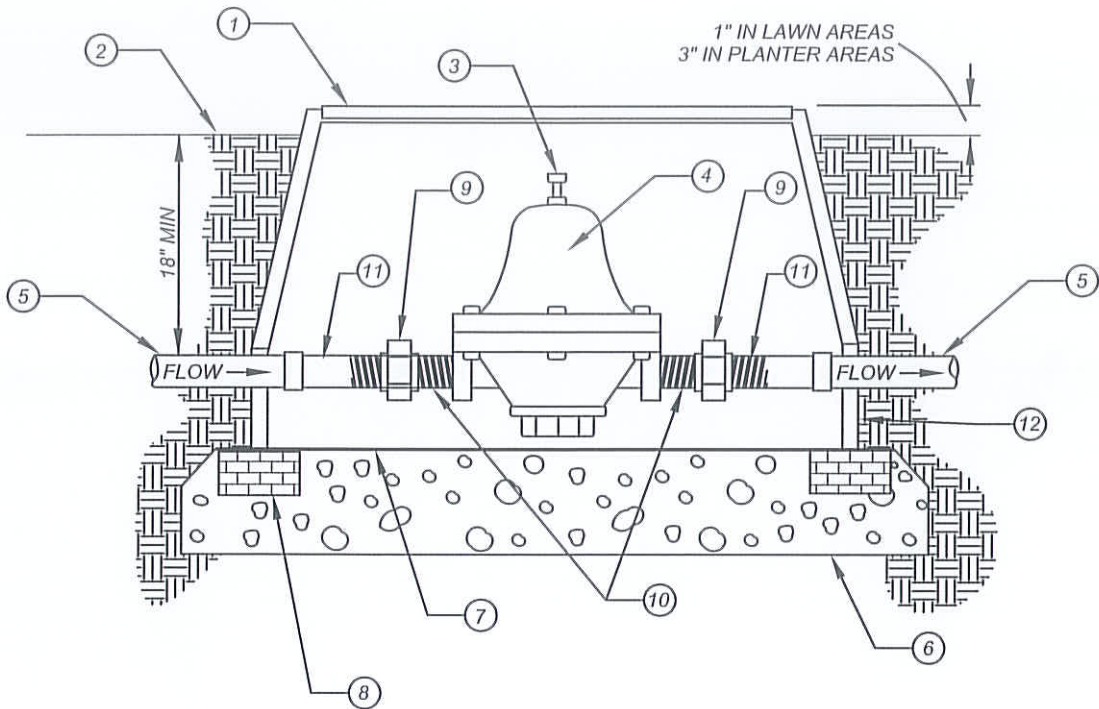

LEGEND:

- ① JUMBO RECTANGULAR PLASTIC VALVE BOX WITH LOCKING LID (PER PLAN AS SPECIFIED), "PR" TO BE BRANDED ON LID
- ② FINISH GRADE
- ③ PRESSURE ADJUSTMENT SCREW
- ④ PRESSURE REGULATOR (PER PLAN AS SPECIFIED)
- ⑤ IRRIGATION MAIN-LINE
- ⑥ 3/4" WASHED CRUSHED AGGREGATE BASE
- ⑦ 1/4" GALVANIZED WIRE MESH
- ⑧ CONCRETE BRICK, TYPICAL OF 4
- ⑨ SCH 80 PVC UNION (FIPT x FIPT)
- ⑩ SCH 80 CLOSE NIPPLE
- ⑪ TOE NIPPLE ASSEMBLY (REFER TO STANDARD MVLI-544A-0)
- ⑫ VALVE BOX EXTENSION (AS NECESSARY)

NOTES:

- 1) PLACE AGGREGATE PRIOR TO INSTALLATION OF BOX.

NOT TO SCALE

	RECOMMENDED: DIVISION MANAGER DATE 1-16-14	<h2 style="margin: 0;">CITY OF MORENO VALLEY</h2> <p style="margin: 0;">FINANCIAL & MANAGEMENT SERVICES DEPARTMENT - SPECIAL DISTRICTS DIVISION</p>	STANDARD PLAN	
	APPROVED: PUBLIC WORKS DIRECTOR / DATE 1/29/14 CITY ENGINEER	<h2 style="margin: 0;">PRESSURE REDUCING VALVE</h2>		<h3 style="margin: 0;">MVLI-550A-0</h3>
				SHEET 1 OF 2

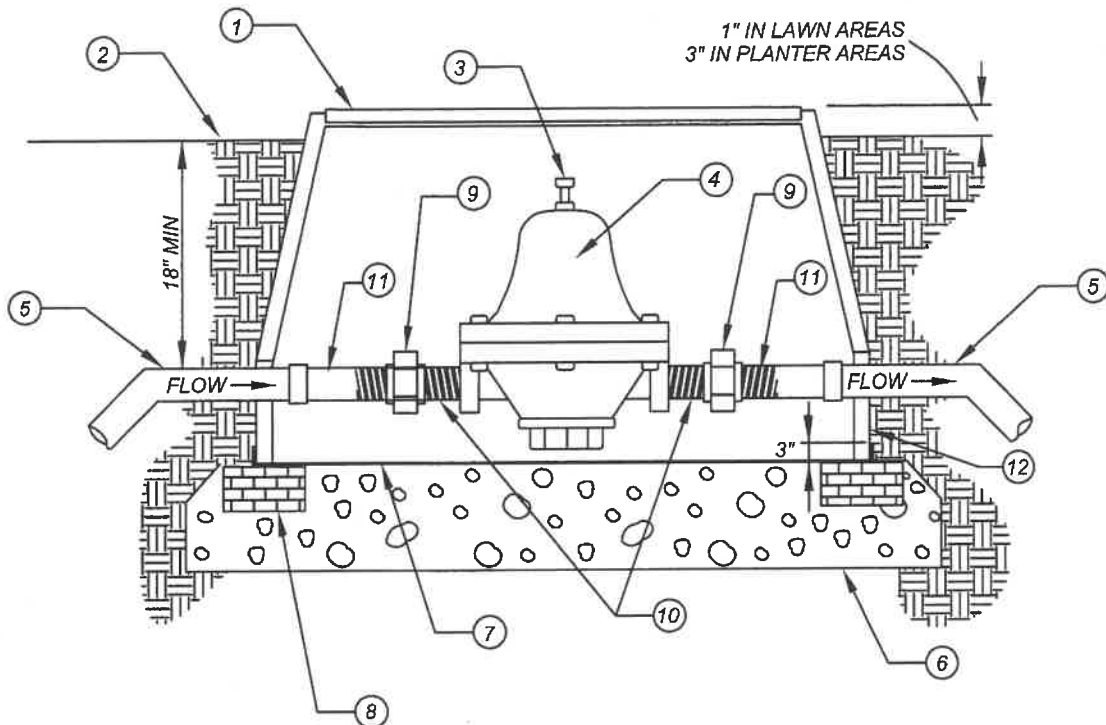





LEGEND:

- ① JUMBO RECTANGULAR PLASTIC VALVE BOX WITH LOCKING LID (PER SPECIFICATIONS), "PR" TO BE BRANDED ON LID
- ② FINISH GRADE
- ③ PRESSURE ADJUSTMENT SCREW
- ④ PRESSURE REGULATOR (PER PLAN AS SPECIFIED)
- ⑤ IRRIGATION MAIN-LINE
- ⑥ 3/4" WASHED CRUSHED AGGREGATE BASE
- ⑦ 1/4" STAINLESS STEEL WIRE MESH, TYPE 316
- ⑧ CONCRETE BRICK, TYPICAL OF 4
- ⑨ SCH 80 PVC UNION (FIPT X FIPT)
- ⑩ SCH 80 CLOSE NIPPLE
- ⑪ TOE NIPPLE ASSEMBLY (REFER TO STANDARD MVLI-544B-0)
- ⑫ VALVE BOX EXTENSION (AS NECESSARY)

NOTES:

- 1) PLACE AGGREGATE PRIOR TO INSTALLATION OF BOX.
- 2) MAINLINE 4" OR LARGER PIPE REQUIRED EPOXY COATED DUCTILE IRON FITTINGS.

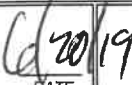
NOT TO SCALE

	RECOMMENDED:  DIVISION MANAGER	 DATE	CITY OF MORENO VALLEY PARKS AND COMMUNITY SERVICES DEPARTMENT
	APPROVED:  PUBLIC WORKS DIRECTOR / CITY ENGINEER	 DATE	PRESSURE REDUCING VALVE

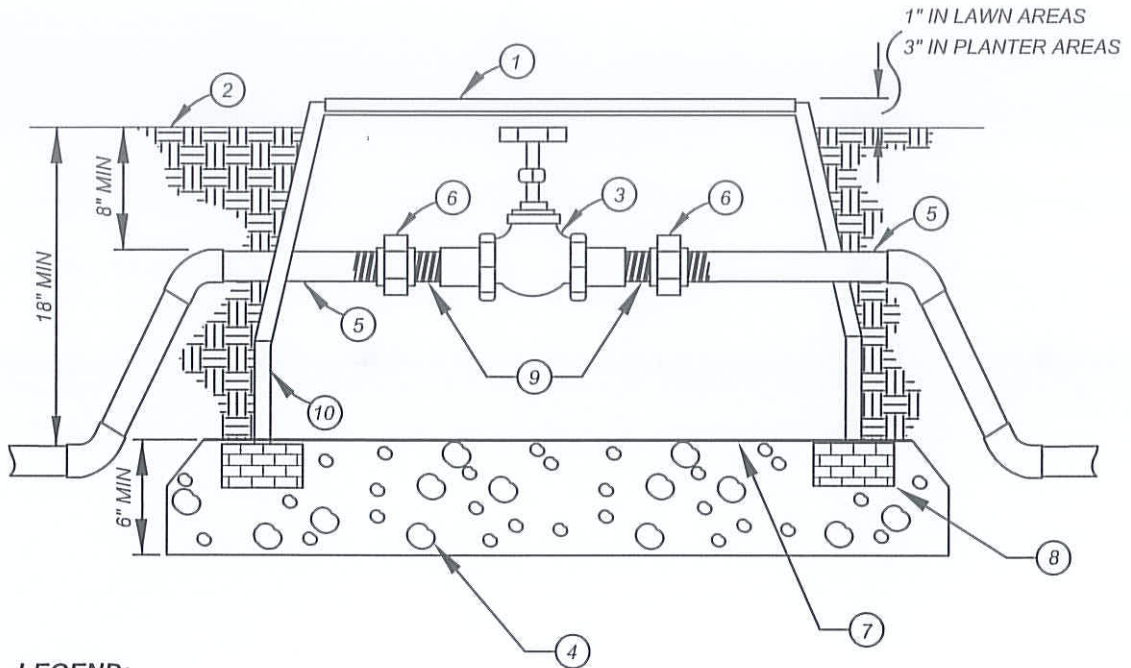

LEGEND:

- ① JUMBO RECTANGULAR PLASTIC VALVE BOX WITH LOCKING LID (PER PLAN AS SPECIFIED), COVER SHALL BE MARKED "BV" OR "GV" VIA BRANDING (2")
- ② FINISH GRADE
- ③ LOCKING BALL VALVE OR GATE VALVE (PER PLAN AS SPECIFIED)
- ④ 3/4" WASHED CRUSHED AGGREGATE BASE
- ⑤ SCH 80 PVC TOE NIPPLE ASSEMBLY (REFER TO STANDARD MVLI-544A-0)
- ⑥ SCH 80 PVC UNION, FIPT x FIPT
- ⑦ 1/4" GALVANIZED WIRE MESH
- ⑧ CONCRETE BLOCK, TYPICAL OF 4
- ⑨ SCH 80 CLOSE NIPPLE
- ⑩ VALVE BOX EXTENSION (AS NECESSARY)

NOTES:

- 1) PLACE AGGREGATE PRIOR TO INSTALLATION OF VALVE BOX.
- 2) IF BALL VALVES ARE USED, A JUMBO RECTANGULAR BOX SHALL BE INSTALLED. BALL VALVES UNDER 2" TO HAVE HANDLE LOCATED VERTICALLY. BALL VALVES LARGER THAN 2" TO HAVE A 2" SQUARE NUT AND DELETE HANDLE.
- 3) CAST IRON AND / OR FLANGED VALVES WILL REQUIRE A POURED-IN-PLACE CONCRETE SUPPORT (NOT SHOWN).

NOT TO SCALE

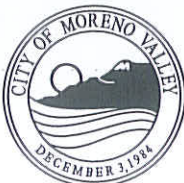

RECOMMENDED:
 DIVISION MANAGER *COX* DATE *1.16.14*
 APPROVED:
 PUBLIC WORKS DIRECTOR / DATE *1/29/14*
 CITY ENGINEER

CITY OF MORENO VALLEY
 FINANCIAL & MANAGEMENT SERVICES DEPARTMENT - SPECIAL DISTRICTS DIVISION

**BALL VALVE / GATE VALVE
 3" OR SMALLER**

STANDARD PLAN
MVLI-551A-0

SHEET 1 OF 2

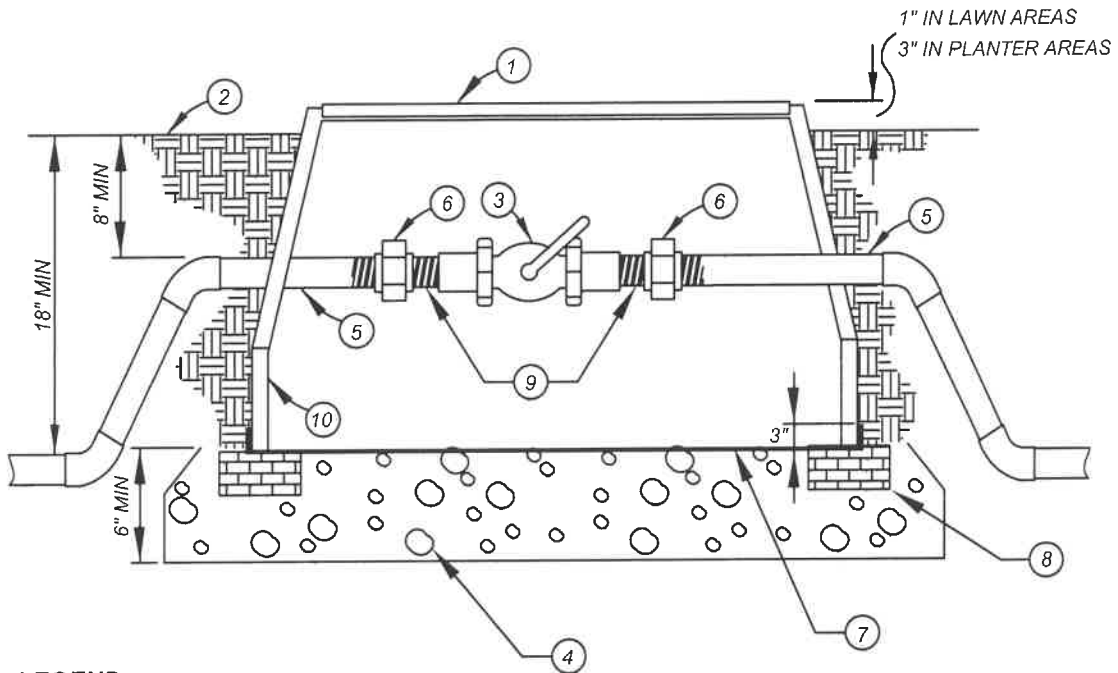



LEGEND:

- ① JUMBO RECTANGULAR PLASTIC VALVE BOX WITH LOCKING LID (PER PLAN AS SPECIFIED), COVER SHALL BE MARKED "BV" OR "GV" VIA BRANDING (2")
- ② FINISH GRADE
- ③ BALL VALVE (PER SPECIFICATIONS)
- ④ 3/4" WASHED CRUSHED AGGREGATE BASE
- ⑤ SCH 80 PVC TOE NIPPLE ASSEMBLY (REFER TO STANDARD MVLI-544B-0)
- ⑥ SCH 80 PVC UNION, FIPT x FIPT
- ⑦ 1/4" STAINLESS STEEL WIRE MESH, TYPE 316
- ⑧ CONCRETE BLOCK, TYPICAL OF 4
- ⑨ SCH 80 CLOSE NIPPLE
- ⑩ VALVE BOX EXTENSION (AS NECESSARY)

NOTES:

- 1) PLACE AGGREGATE PRIOR TO INSTALLATION OF VALVE BOX.
- 2) A JUMBO RECTANGULAR BOX SHALL BE INSTALLED. BALL VALVES UNDER 2" TO HAVE HANDLE LOCATED VERTICALLY. BALL VALVES LARGER THAN 2" TO HAVE A 2" SQUARE NUT AND DELETE HANDLE.
- 3) CAST IRON AND / OR FLANGED VALVES WILL REQUIRE A POURED-IN-PLACE CONCRETE SUPPORT (NOT SHOWN).

NOT TO SCALE

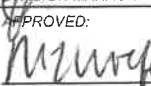
	RECOMMENDED:  DIVISION MANAGER / DATE 9/20/19	<h2 style="margin: 0;">CITY OF MORENO VALLEY</h2> <p style="margin: 0;">PARKS AND COMMUNITY SERVICES DEPARTMENT</p>	STANDARD PLAN MVLI-551B-0
	APPROVED:  PUBLIC WORKS DIRECTOR / DATE 10/11/19 CITY ENGINEER	<h3 style="margin: 0;">BALL VALVE / GATE VALVE</h3> <h3 style="margin: 0;">3" OR SMALLER</h3>	SHEET 2 OF 2

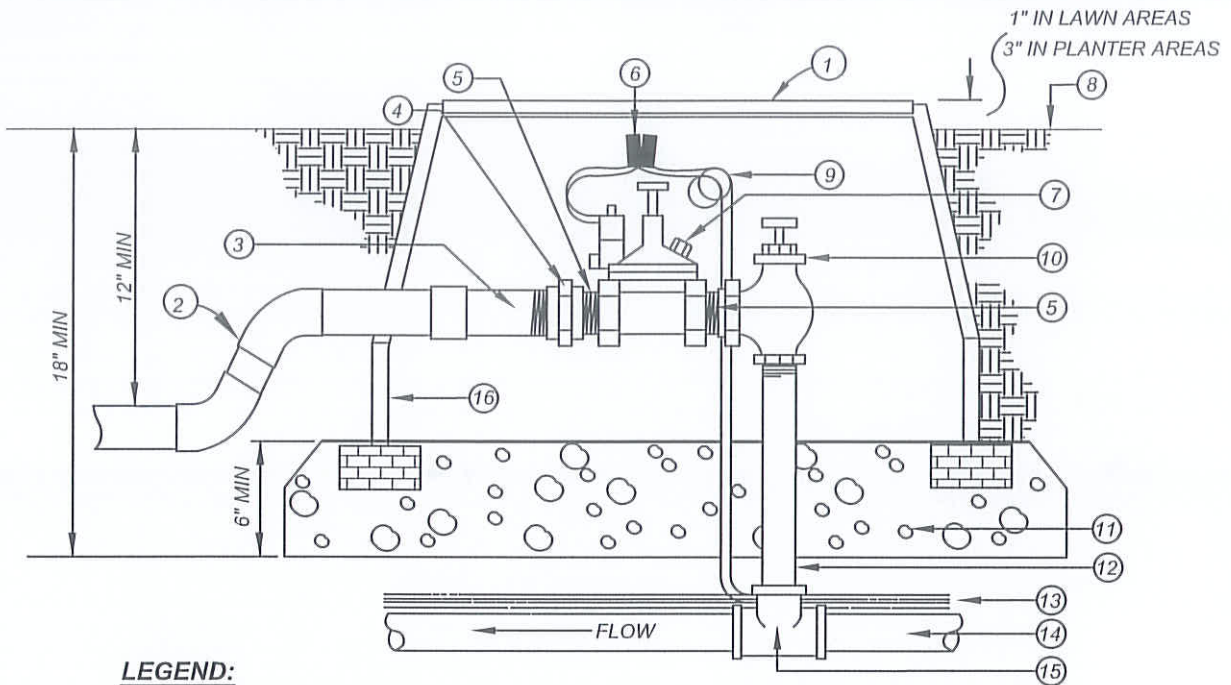

LEGEND:

- ① JUMBO RECTANGULAR PLASTIC VALVE BOX WITH LOCKING LID (PER PLAN AS SPECIFIED), SHALL BE "RCV" WITH STATION NUMBERS FOR CONTROL VALVES BRANDED ON LID
- ② PVC LATERAL LINE - ANGLE PIPE TO SPECIFIED DEPTH WITH 45 DEGREE ELLS AS NECESSARY
- ③ SCH 80 PVC TOE NIPPLE ASSEMBLY (REFER TO STANDARD MVLI-544A-0)
- ④ SCH 80 PVC UNION (FIPT x FIPT)
- ⑤ SCH 80 PVC CLOSE NIPPLE
- ⑥ WATER PROOF CONNECTORS, (SEE STANDARD MVLI-545A-0)
- ⑦ ELECTRIC CONTROL VALVE
- ⑧ FINISH GRADE
- ⑨ PIG TAIL EXPANSION LOOP (MIN 24" LONG)
- ⑩ BRASS ANGLE VALVE WITH UNION
- ⑪ WASHED CRUSHED AGGREGATE
- ⑫ SCH 80 PVC NIPPLE
- ⑬ CONTROL & COMMON WIRES (REFER TO STANDARD MVLI-560A-0)
- ⑭ IRRIGATION MAIN-LINE
- ⑮ SCH 80 PVC S x S x S TEE
- ⑯ VALVE BOX EXTENSION (AS NECESSARY)

NOTES:

- 1) INSTALL CONTROL VALVES A MINIMUM OF 12" FROM STRUCTURES OR HARDSCAPE.
- 2) INSTALL VALVES IN PLANTER BEDS WHEREVER POSSIBLE NEXT TO SIDEWALKS.
- 3) PLACE VALVE BOX PARALLEL TO STRUCTURES OR HARDSCAPE.
- 4) PLACE AGGREGATE PRIOR TO INSTALLATION OF VALVE BOX.
- 5) ATTACH VALVE IDENTIFICATION TAG WITH APPROPRIATE CONTROLLER DESIGNATION TO CONTROL WIRE.
- 6) ONLY ONE VALVE PER BOX ALLOWED.
- 7) PLACE AGGREGATE PRIOR TO INSTALLATION OF VALVE BOX.

NOT TO SCALE

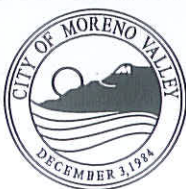

RECOMMENDED:
 COS 1-16-24
 DIVISION MANAGER DATE
 APPROVED:
 [Signature] 1/29/14
 PUBLIC WORKS DIRECTOR / DATE
 CITY ENGINEER

CITY OF MORENO VALLEY
 FINANCIAL & MANAGEMENT SERVICES DEPARTMENT - SPECIAL DISTRICTS DIVISION

**REMOTE CONTROL VALVE
 WITH UNION**

STANDARD PLAN
MVLI-552A-0

SHEET 1 OF 2

LEGEND:

- 1 JUMBO/SUPER JUMBO VALVE BOX WITH COVER PER SPECIFICATIONS
- 2 CONNECTORS PER SPECIFICATIONS
- 3 1" ABOVE GRADE TOP IN TURF AREAS
3" ABOVE GRADE IN SHRUB AREAS
- 4 RAINBIRD EFB-CP-PRS-D RCV (UP TO 2")
- 5 SCH 80 PVC THREADED UNION (2)
- 6 PVC SCH 80 MALE ADAPTER
- 7 LATERAL LINE ANGLE WITH 45 DEGREE ELLS TO SPECIFIED DEPTH
- 8 CONCRETE BRICK SUPPORT AT EACH CORNER
- 9 3/4" GRAVEL SUMP - MINIMUM 6"
- 10 WIRE EXPANSION LOOP (MIN 24" LENGTH)
- 11 FEBCO T585-70-66 BRONZE BALL VALVE
- 12 PVC SCH 80, 90 DEGREE ELL
- 13 SCH 80 SST, MAINLINE SIZE (LEEMCO RESTRAINT TEE ON 4" AND LARGER PIPE)
- 14 CHRISTY TAG WITH VALVE AND STATION NUMBER
- 15 1/4" STAINLESS STEEL WIRE MESH, TYPE 316
- 16 SCH 80 NIPPLE

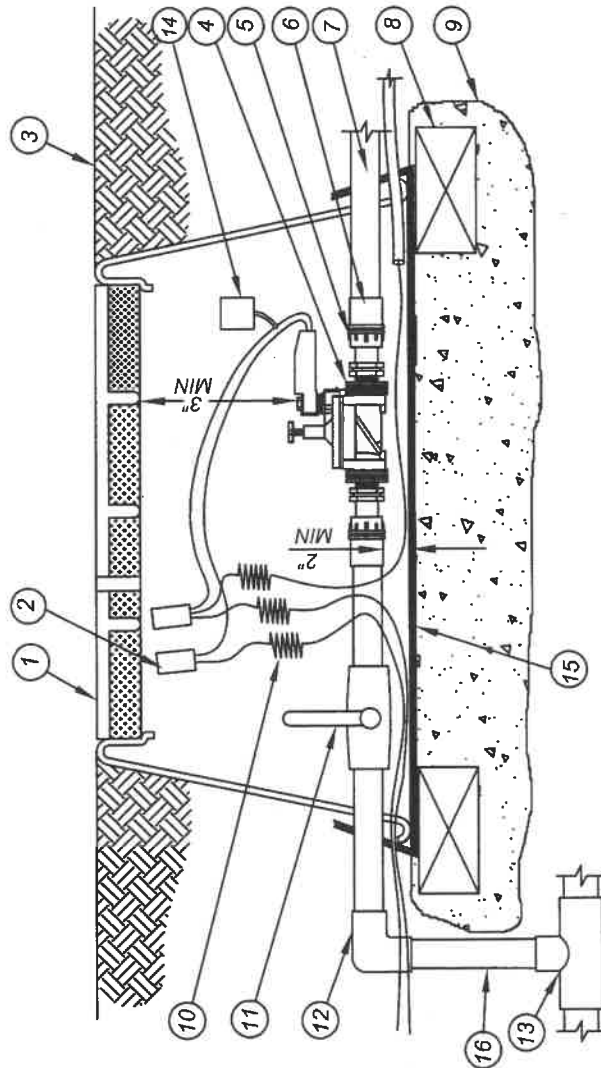

NOTES:

- 1.) INSTALL CONTROL VALVES A MINIMUM OF 24" FROM STRUCTURES OR HARDSCAPE.
- 2.) INSTALL VALVES IN PLANT BEDS WHEREVER POSSIBLE NEXT TO SIDEWALKS.
- 3.) PLACE VALVE BOX AT RIGHT ANGLES TO STRUCTURES OR HARDSCAPE.
- 4.) PLACE AGGREGATE PRIOR TO INSTALLATION OF VALVE BOX.
- 5.) ATTACH VALVE IDENTIFICATION TAG WITH APPROPRIATE CONTROLLER AND VALVE NUMBER TO CONTROL WIRE.
- 6.) ONE VALVE PER BOX ALLOWED ONLY.

NOT TO SCALE



RECOMMENDED: *[Signature]* 6/20/19
 DIVISION MANAGER DATE
 APPROVED: *[Signature]* 7/30/19
 PUBLIC WORKS DIRECTOR / DATE
 CITY ENGINEER

CITY OF MORENO VALLEY
 PARKS AND COMMUNITY SERVICES DEPARTMENT

**REMOTE CONTROL VALVE
 DETAIL**

STANDARD PLAN
MVLI-552B-0
 SHEET 2 OF 2

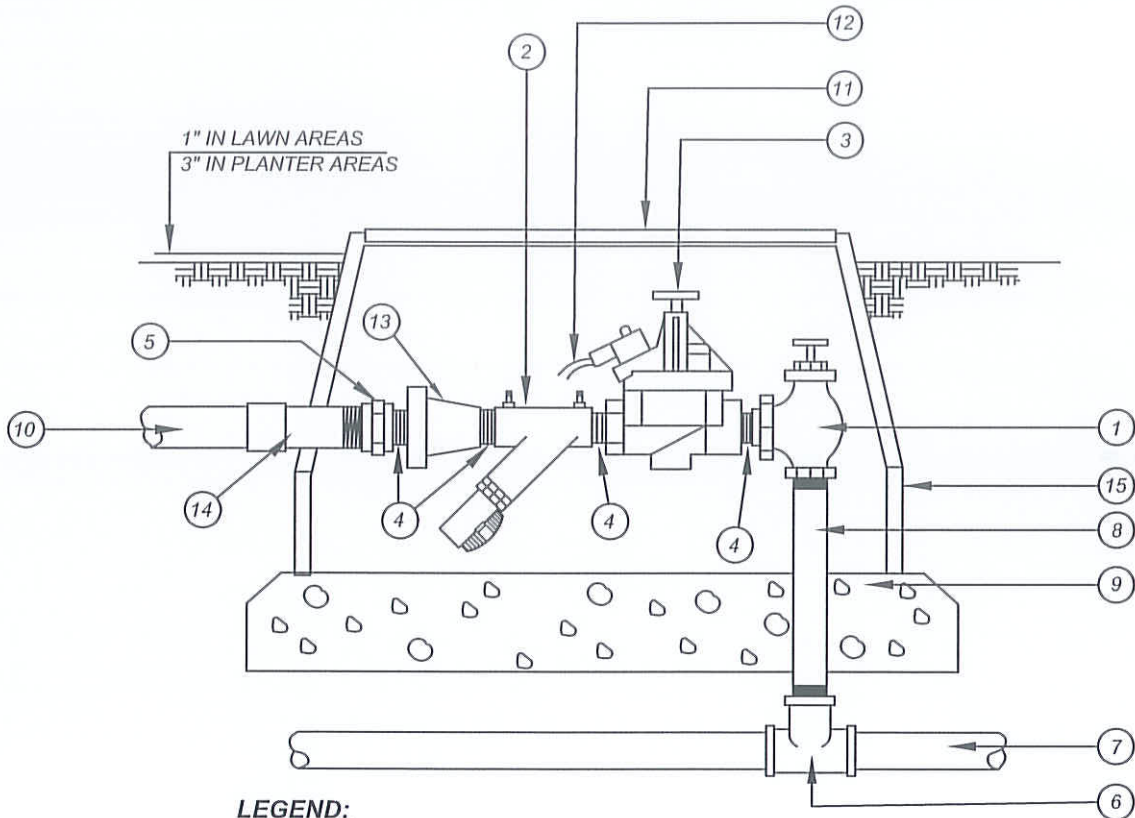

LEGEND:

- ① BRASS ANGLE VALVE WITH UNION - SAME SIZE AS RCV
- ② IN-LINE WYE FILTER (PER PLAN AS SPECIFIED)
- ③ REMOTE CONTROL VALVE (PER PLAN AS SPECIFIED)
- ④ SCH 80 PVC CLOSE NIPPLE
- ⑤ SCH 80 UNION (FIPT X FIPT)
- ⑥ SCH 80 PVC S x S x T TEE
- ⑦ IRRIGATION MAIN-LINE
- ⑧ SCH 80 PVC NIPPLE
- ⑨ 6" THICK 3/4" WASHED CRUSHED AGGREGATE
- ⑩ LATERAL LINE (PER PLAN AS SPECIFIED)
- ⑪ JUMBO RECTANGULAR PLASTIC VALVE BOX WITH LOCKING LID (PER PLAN AS SPECIFIED), SHALL BE BRANDED "RCV" WITH STATION NUMBERS FOR CONTROL VALVES
- ⑫ SOLENOID WIRES. PIG-TAIL EACH 24" LONG
- ⑬ PRESSURE REGULATOR (PER PLAN AS SPECIFIED)
- ⑭ SCH 80 TOE NIPPLE ASSEMBLY (REFER TO STANDARD MVLI-544A-0)
- ⑮ VALVE BOX EXTENSION (AS NECESSARY)

NOTES:

1) PLACE AGGREGATE PRIOR TO INSTALLING VALVE BOX.

NOT TO SCALE

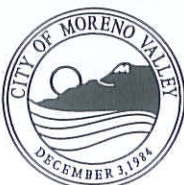

RECOMMENDED:
COS 1-10-14
 DIVISION MANAGER DATE
 APPROVED:
MM 1/29/14
 PUBLIC WORKS DIRECTOR / DATE
 CITY ENGINEER

CITY OF MORENO VALLEY
 FINANCIAL & MANAGEMENT SERVICES DEPARTMENT - SPECIAL DISTRICTS DIVISION-

**REMOTE CONTROL VALVE
 FOR DRIP SYSTEMS**

STANDARD PLAN
MVLI-553A-0

SHEET 1 OF 2

LEGEND:

- 1 SUPER JUMBO VALVE BOX WITH COVER PER SPECIFICATIONS
- 2 CONNECTORS PER SPECIFICATIONS.
- 3 1" ABOVE GRADE TOP IN TURF AREAS
3" ABOVE GRADE IN SHRUB AREAS
- 4 RCV PER SPECIFICATIONS
- 5 SCH 80 PVC THREADED UNION (2)
- 6 PVC SCH 80 NIPPLE
- 7 LATERAL LINE ANGLE WITH 45 DEGREE ELLS TO SPECIFIED DEPTH
- 8 CONCRETE BRICK SUPPORT AT EACH CORNER
- 9 3/4" GRAVEL SUMP - MINIMUM 6"
- 10 WIRE EXPANSION LOOP (MIN 24" LENGTH)
- 11 FEBCO T585-70-66 BRONZE BALL VALVE
- 12 PVC SCH 80 90 DEGREE ELL
- 13 SCH 80 SST. MAINLINE SIZE (LEEMCO RESTRAINT TEE ON 4" AND LARGER PIPE)
- 14 CHRISTY TAG WITH VALVE AND STATION NUMBER
- 15 1/4" STAINLESS STEEL MESH SCREEN, TYPE 316
- 16 SCH 80 NIPPLE
- 17 PRESSURE REGULATOR PER SPECIFICATIONS
- 18 FILTER PER SPECIFICATIONS

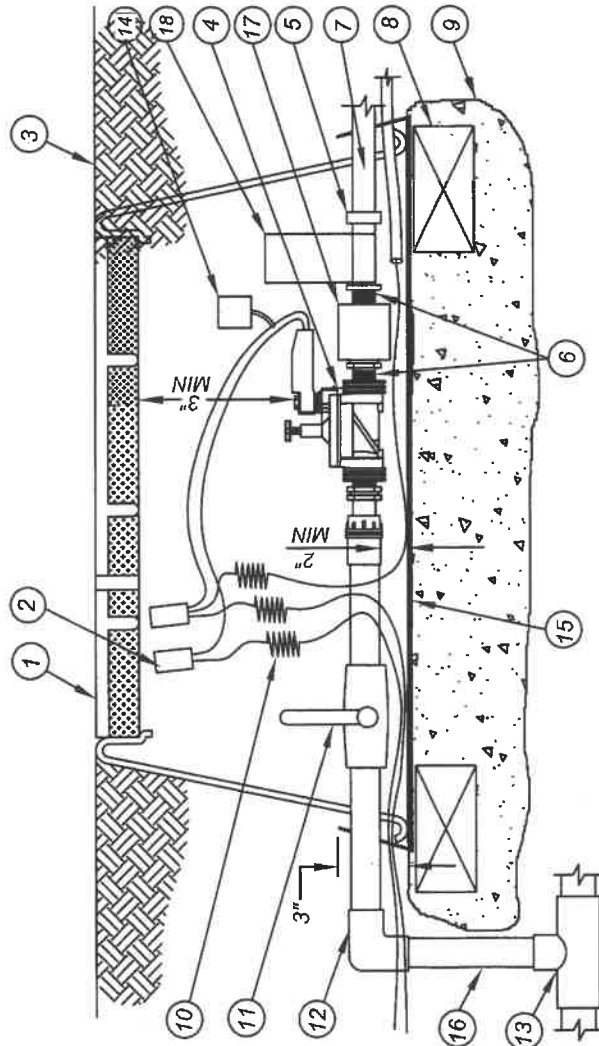

NOTES:

- 1.) INSTALL CONTROL VALVES A MINIMUM OF 24" FROM STRUCTURES OR HARDSCAPE.
- 2.) INSTALL VALVES IN PLANT BEDS WHEREVER POSSIBLE NEXT TO SIDEWALKS.
- 3.) PLACE VALVE BOX AT RIGHT ANGLES TO STRUCTURES OR HARDSCAPE.
- 4.) PLACE AGGREGATE PRIOR TO INSTALLATION OF VALVE BOX.
- 5.) ATTACH VALVE IDENTIFICATION TAG WITH APPROPRIATE CONTROLLER AND VALVE NUMBER TO CONTROL WIRE.
- 6.) ONE VALVE PER BOX ALLOWED ONLY.

NOT TO SCALE

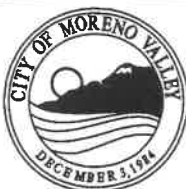

RECOMMENDED: *[Signature]* 6/20/19
 DIVISION MANAGER DATE
 APPROVED: *[Signature]* 7/30/19
 PUBLIC WORKS DIRECTOR / DATE
 CITY ENGINEER

CITY OF MORENO VALLEY
 PARKS AND COMMUNITY SERVICES DEPARTMENT

**REMOTE CONTROL VALVE DETAIL
 FOR DRIP SYSTEMS**

STANDARD PLAN
MVLI-553B-0

SHEET 2 OF 2

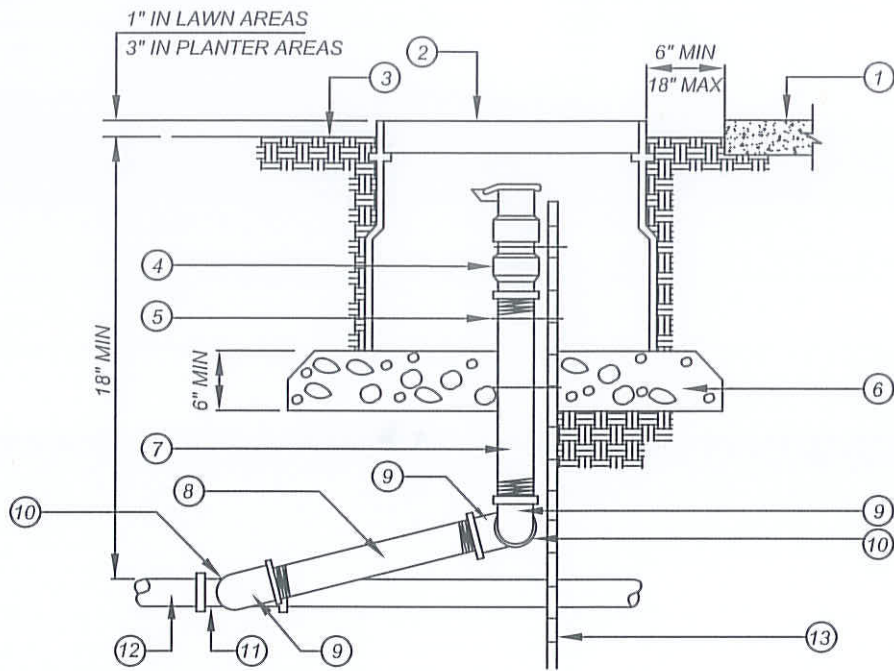

LEGEND:

- ① STRUCTURE OR HARDSCAPE
- ② 10" ROUND VALVE BOX WITH "QC" BRANDED ON LID
- ③ FINISH GRADE
- ④ QUICK COUPLING VALVE (PER PLAN AS SPECIFIED)
- ⑤ STAINLESS STEEL SCREW CLAMP MINIMUM (3) PLACES
- ⑥ 3/4" WASHED CRUSHED AGGREGATE BASE
- ⑦ SCH 80 NIPPLE - 10" LONG
- ⑧ SCH 80 NIPPLE - 12" LONG
- ⑨ SCH 80 (FIPT x FIPT) PVC 90 DEGREE ELL
- ⑩ SCH 80 PVC CLOSE NIPPLE
- ⑪ PRESSURE SUPPLY LINE FITTING, (LINE SIZE SCH 80 TEE - S x S x T, OR 90 DEGREE ELL WITH SCH 80 REDUCER BUSHING - SPIG x FIPT)
- ⑫ IRRIGATION MAIN-LINE
- ⑬ No 4 REBAR STAKE (24" LONG)

NOTES:

- 1) PLACE AGGREGATE BASE PRIOR TO INSTALLATION OF VALVE BOX.
- 2) INSTALL Q.C.V. & BOX IN PLANTERS WHEN EVER POSSIBLE, NOT IN TURF AREAS.

NOT TO SCALE

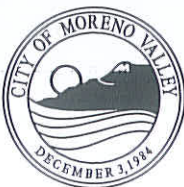

RECOMMENDED:
 COS 1.16.14
 DIVISION MANAGER DATE
 APPROVED:
 MW 1/29/14
 PUBLIC WORKS DIRECTOR / DATE
 CITY ENGINEER

CITY OF MORENO VALLEY
 FINANCIAL & MANAGEMENT SERVICES DEPARTMENT - SPECIAL DISTRICTS DIVISION

QUICK COUPLING VALVE

STANDARD PLAN
MVLI-554A-0

SHEET 1 OF 2

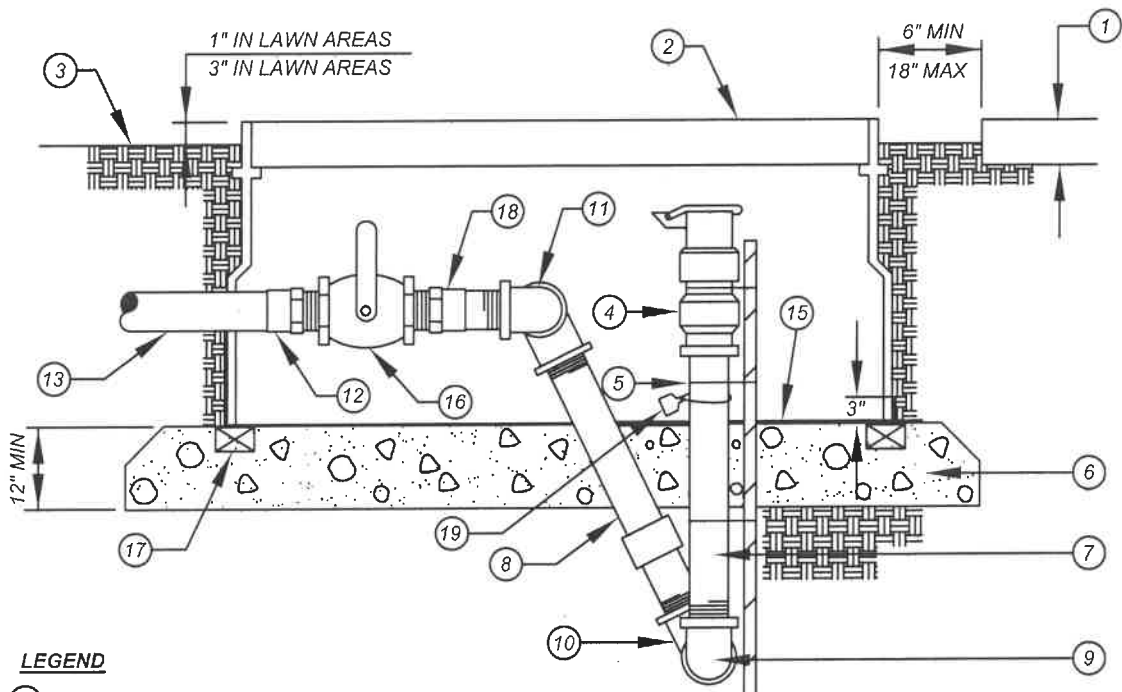

LEGEND

- 1 STRUCTURE OR HARDSCAPE
- 2 JUMBO RECTANGULAR PLASTIC VALVE BOX & COVER- COVER SHALL BE HEAT STAMPED WITH LETTERS "QC" HEAT STAMPED INTO COVER BY CONTRACTOR
- 3 FINISH GRADE
- 4 QUICK COUPLING VALVE
- 5 STAINLESS STEEL SCREW, CLAMP MIN (3) PLACES
- 6 3/4" DIA WASHED CRUSHED AGGREGATE
- 7 BRASS NIPPLE
- 8 BRASS NIPPLE - 6" LONG x 1" DIAMETER
- 9 BRASS 90 DEGREE ELL
- 10 BRASS 90 DEGREE STREET ELL
- 11 BRASS 90 DEGREE STREET ELL
- 12 PRESSURE SUPPLY LINE FITTING
- 13 PRESSURE SUPPLY LINE WITH MINIMUM SIZE 1 1/2"
- 14 No 4 BILLET BAR (24" LONG)
- 15 1/4" MESH STAINLESS STEEL SCREEN, TYPE 316
- 16 NIBCO T585-70-66 BALL VALVE - 1 1/2"
- 17 CONCRETE BRICK SUPPORTS (TYP OF 4)
- 18 1" TOE NIPPLE ASSEMBLY AND REDUCER BUSHING
- 19 CHRISTY TAG LABELLED "DO NOT DRINK" WITH SYMBOL

NOTES:

1. PLACE STABILIZER PRIOR TO INSTALLATION OF VALVE BOX

NOT TO SCALE



RECOMMENDED:

DIVISION MANAGER

DATE

APPROVED:

PUBLIC WORKS DIRECTOR /
CITY ENGINEER

DATE

CITY OF MORENO VALLEY

PARKS AND COMMUNITY SERVICES DEPARTMENT

QUICK COUPLER BALL VALVE

STANDARD PLAN

MVLI-554B-0

SHEET 2 OF 2

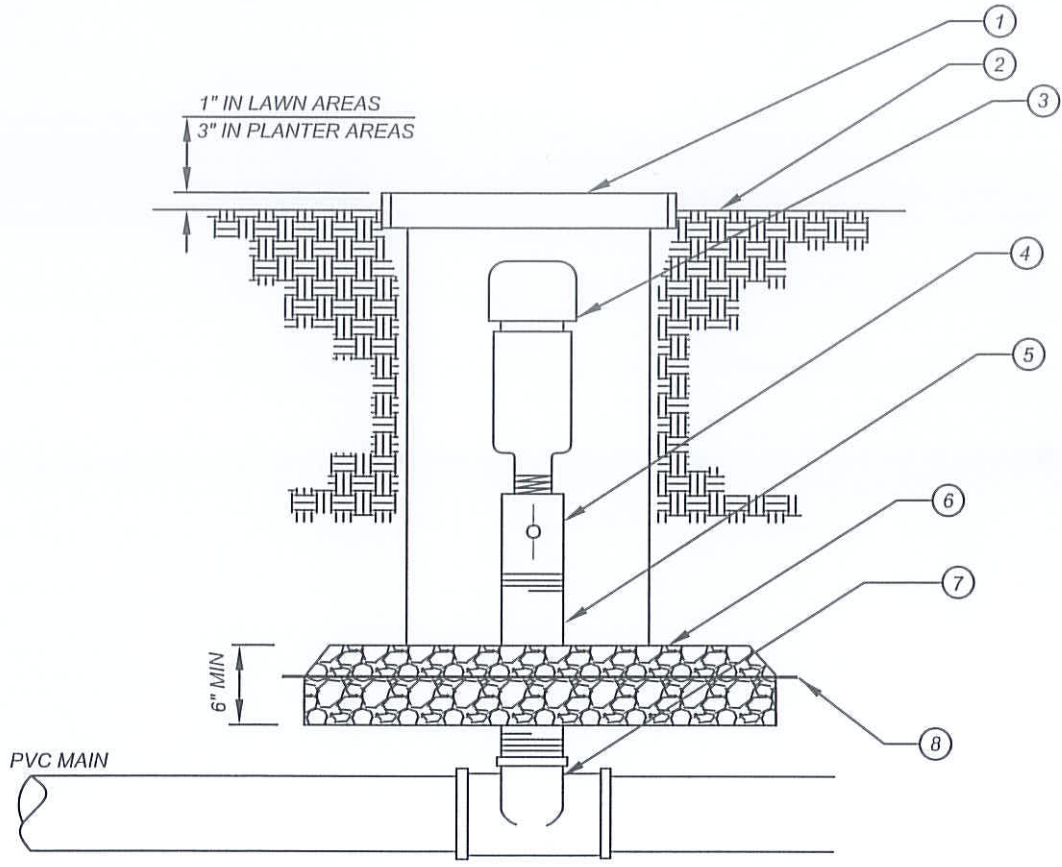

LEGEND:

- ① 10" ROUND VALVE BOX WITH LOCKING LID, "ARV" TO BE BRANDED ON LID. USE VALVE BOX EXTENSIONS AS NECESSARY TO REACH FINISH GRADE
- ② FINISH GRADE
- ③ 1" AIR/VACUUM RELIEF VALVE
- ④ 1" SCH 80 PVC BALL VALVE (FIPT X FIPT)
- ⑤ 1" SCH 80 PVC NIPPLE
- ⑥ 3/4" WASHED CRUSHED AGGREGATE BASE
- ⑦ SCH 80 PVC TEE (S x S x T) OR 90° ELL (S x T)
- ⑧ 1/4" GALVANIZED MESH WIRE

NOTES:

- 1) PLACE AGGREGATE PRIOR TO INSTALLATION OF BOX.

NOT TO SCALE

	RECOMMENDED: <i>COS</i> 1-16-14 DIVISION MANAGER DATE	<h2 style="margin: 0;">CITY OF MORENO VALLEY</h2> <p style="margin: 0;">FINANCIAL & MANAGEMENT SERVICES DEPARTMENT - SPECIAL DISTRICTS DIVISION</p>		
	APPROVED: 1/29/14 PUBLIC WORKS DIRECTOR / DATE CITY ENGINEER	<h3 style="margin: 0;">AIR VACUUM RELIEF VALVE</h3>		STANDARD PLAN MVLI-555A-0
	SHEET 1 OF 2			

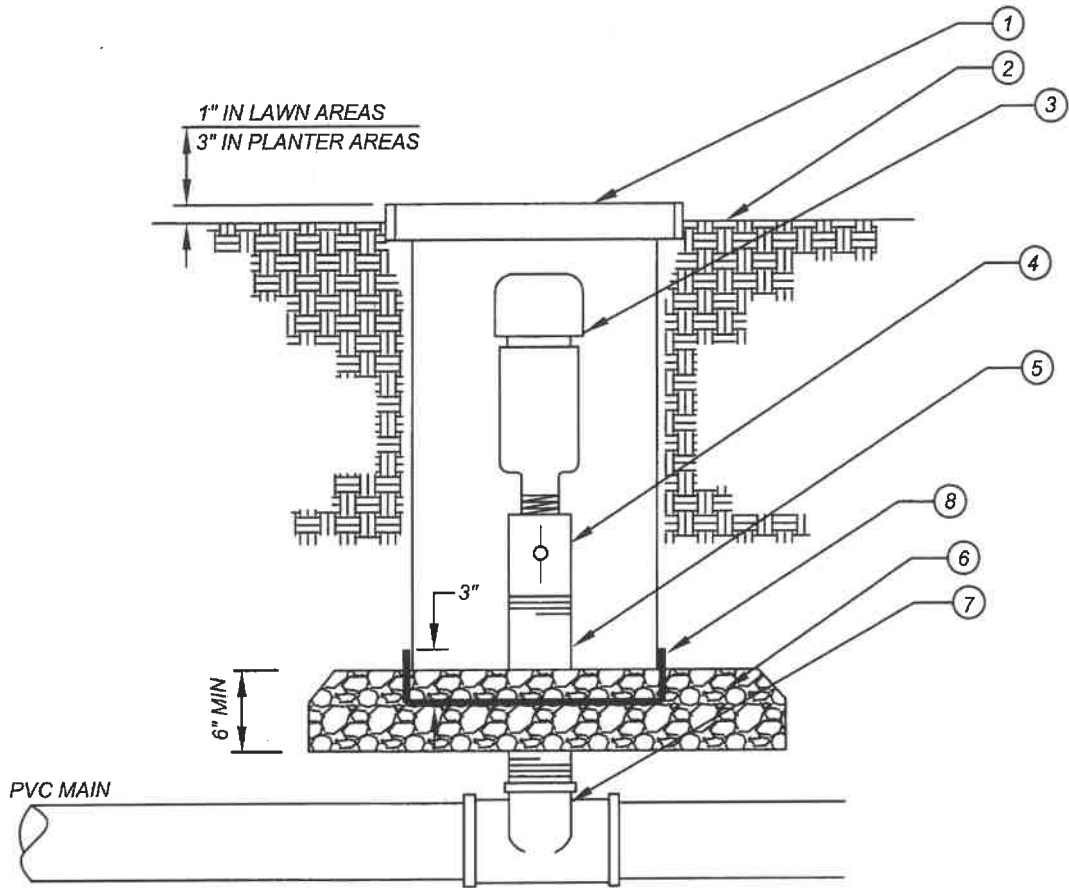



LEGEND:

- ① 10" ROUND VALVE BOX WITH LOCKING LID, "ARV" TO BE BRANDED ON LID. USE VALVE BOX EXTENSIONS AS NECESSARY TO REACH FINISH GRADE
- ② FINISH GRADE
- ③ 1" AIR/VACUUM RELIEF VALVE
- ④ 1" SCH 80 PVC BALL VALVE (FIPT X FIPT)
- ⑤ 1" SCH 80 PVC NIPPLE
- ⑥ 3/4" WASHED CRUSHED AGGREGATE BASE
- ⑦ SCH 80 PVC TEE (S x S x T) OR 90° ELL (S x T)
- ⑧ 1/4" STAINLESS STEEL WIRE MESH WIRE, TYPE 316

NOTES:

- 1) PLACE AGGREGATE PRIOR TO INSTALLATION OF BOX.

NOT TO SCALE

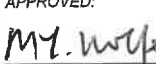
	RECOMMENDED:  DIVISION MANAGER DATE	<h2 style="margin: 0;">CITY OF MORENO VALLEY</h2> <p style="margin: 0;">PARKS AND COMMUNITY SERVICES DEPARTMENT</p>	STANDARD PLAN
	APPROVED:  PUBLIC WORKS DIRECTOR / DATE CITY ENGINEER	<h3 style="margin: 0;">AIR VACUUM RELIEF VALVE</h3>	MVLI-555B-0
			SHEET 2 OF 2

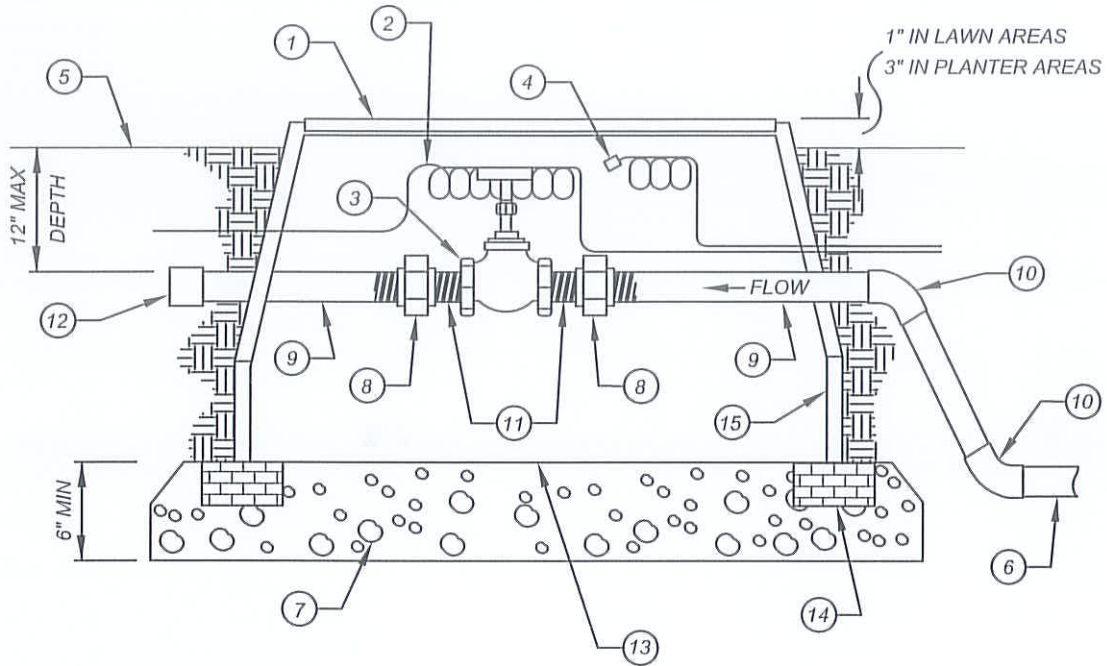

LEGEND:

- | | |
|--|--|
| ① JUMBO RECTANGULAR PLASTIC VALVE BOX WITH LOCKING LID (PER PLAN AS SPECIFIED) BRANDED WITH "GV" OR "BV" | ⑦ 3/4" WASHED CRUSHED AGGREGATE BASE |
| ② PIG-TAIL COMMON WIRE (CONTINUOUS LOOP) | ⑧ SCH 80 UNION (FIPT x FIPT) |
| ③ BALL VALVE OR GATE VALVE (PER PLAN AS SPECIFIED) | ⑨ SCH 80 TOE NIPPLE ASSEMBLY (REFER TO STANDARD MVLI-544A-0) |
| ④ PIG-TAIL PILOT WIRE AND WATERPROOF END (REFER TO STANDARD MVLI-545A-0) | ⑩ SCH 80 45° ELBOWS |
| ⑤ FINISH GRADE | ⑪ SCH 80 PVC CLOSE NIPPLES |
| ⑥ IRRIGATION MAIN-LINE | ⑫ SCH 80 PVC CAP |
| | ⑬ 1/4" GALVANIZED WIRE MESH |
| | ⑭ CONCRETE BRICK, TYPICAL OF 4 |
| | ⑮ VALVE BOX EXTENSION (AS NECESSARY) |

NOTES:

1) PLACE AGGREGATE AND MESH PRIOR TO INSTALLING BOX.

NOT TO SCALE

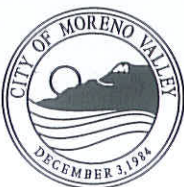

RECOMMENDED:
ROS 1-16-14
 DIVISION MANAGER DATE
 APPROVED:
[Signature] 1/29/14
 PUBLIC WORKS DIRECTOR / DATE
 CITY ENGINEER

CITY OF MORENO VALLEY
 FINANCIAL & MANAGEMENT SERVICES DEPARTMENT - SPECIAL DISTRICTS DIVISION

IRRIGATION STUB-OUT BOX

STANDARD PLAN
MVLI-556A-0

SHEET 1 OF 2

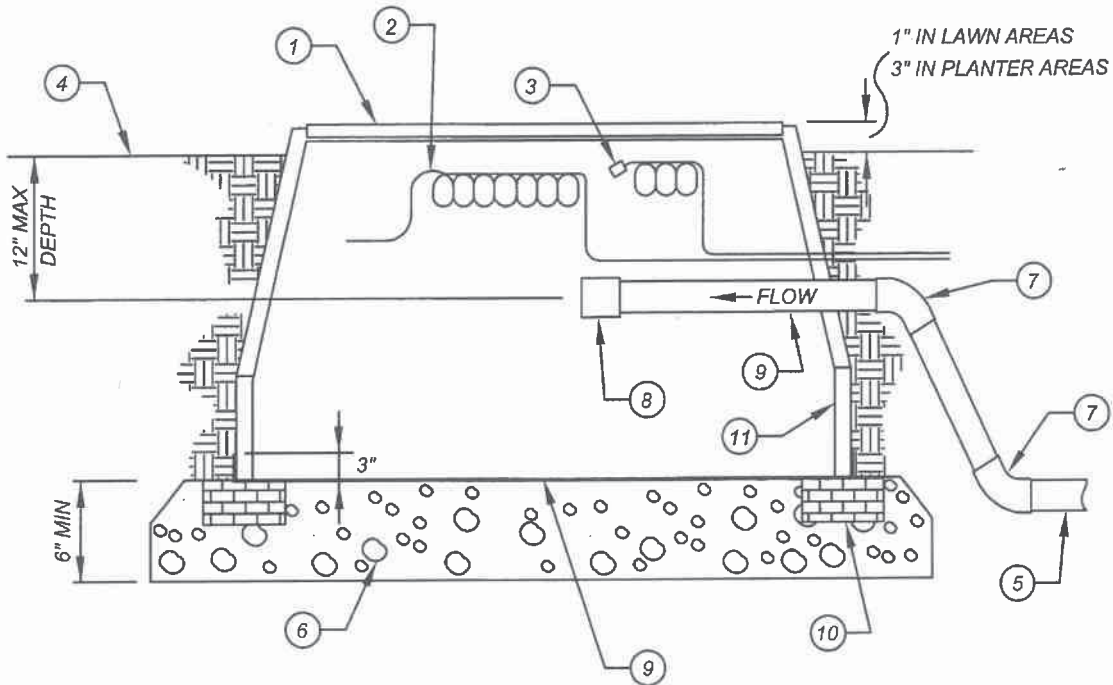

LEGEND:

- | | |
|--|--|
| ① JUMBO RECTANGULAR PLASTIC VALVE BOX WITH LOCKING LID (PER PLAN AS SPECIFIED) BRANDED WITH "GV" OR "BV" | ⑥ 3/4" WASHED CRUSHED AGGREGATE BASE |
| ② PIG-TAIL COMMON WIRE (CONTINUOUS LOOP) | ⑦ SCH 80 45° ELBOWS |
| ③ PIG-TAIL PILOT WIRE AND WATERPROOF END | ⑧ SCH 80 PVC CAP |
| ④ FINISH GRADE | ⑨ 1/4" STAINLESS STEEL WIRE MESH, TYPE 316 |
| ⑤ IRRIGATION MAIN-LINE | ⑩ CONCRETE BRICK, TYPICAL OF 4 |
| | ⑪ VALVE BOX EXTENSION (AS NECESSARY) |

NOTES:

1) PLACE AGGREGATE AND MESH PRIOR TO INSTALLING BOX.

NOT TO SCALE



RECOMMENDED:

DIVISION MANAGER

DATE

APPROVED:

Mr. Wolfe

7/30/19

PUBLIC WORKS DIRECTOR /
CITY ENGINEER

DATE

CITY OF MORENO VALLEY

PARKS AND COMMUNITY SERVICES DEPARTMENT

IRRIGATION STUB-OUT BOX

STANDARD PLAN

MVLI-556B-0

SHEET 2 OF 2

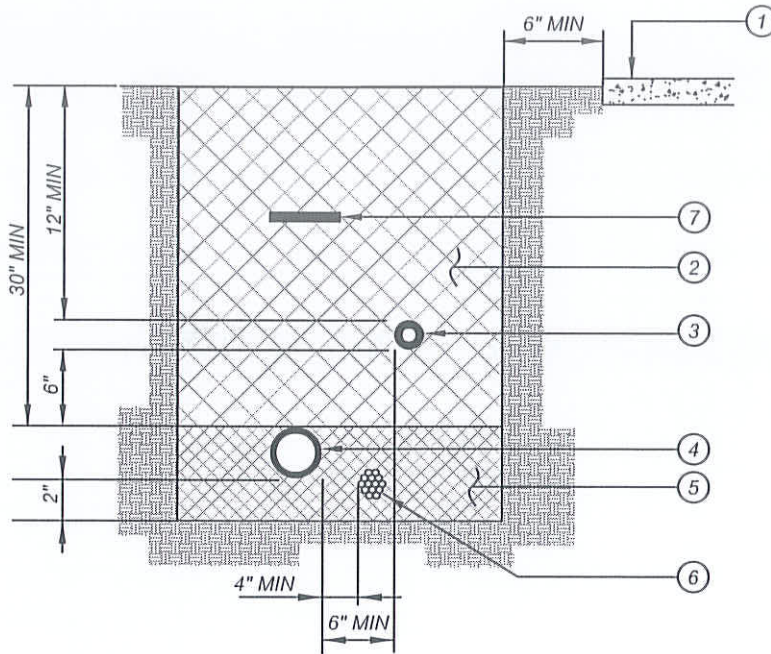



LEGEND:

- ① ADJACENT WALK OR FINISHED SURFACE
- ② CLEAN BACKFILL - SEE SPECIFICATIONS FOR MATERIAL, 90% COMPACTION REQUIRED
- ③ NON-PRESSURE LATERAL LINE
- ④ IRRIGATION MAIN-LINE
- ⑤ PROVIDE WASHED SAND BACKFILL
- ⑥ CONTROL WIRES - BUNDLE AND TAPE AT 15' OC AND INSTALL BELOW AND OFFSET FROM IRRIGATION MAIN-LINE
- ⑦ WATER WARNING TAPE PER CITY LANDSCAPE GUIDELINES

NOTES:

- 1.) PIGTAIL AND/OR LOOP CONTROL WIRE AT ALL 90 DEGREE CHANGES IN DIRECTION
- 2.) SPLICING OF WIRE RUN PER CITY LANDSCAPE SPECIFICATIONS ONLY
- 3.) 30" MINIMUM COVER FOR RECLAIMED WATER MAINLINE

NOT TO SCALE

	RECOMMENDED:  1-16-14 DIVISION MANAGER DATE	<h2 style="margin: 0;">CITY OF MORENO VALLEY</h2> <p style="margin: 0;">FINANCIAL & MANAGEMENT SERVICES DEPARTMENT - SPECIAL DISTRICTS DIVISION</p>	STANDARD PLAN <h3 style="margin: 0;">MVLI-560A-0</h3>
	APPROVED:  1/29/14 PUBLIC WORKS DIRECTOR / DATE CITY ENGINEER	<h2 style="margin: 0;">LANDSCAPE TRENCH DETAIL</h2>	

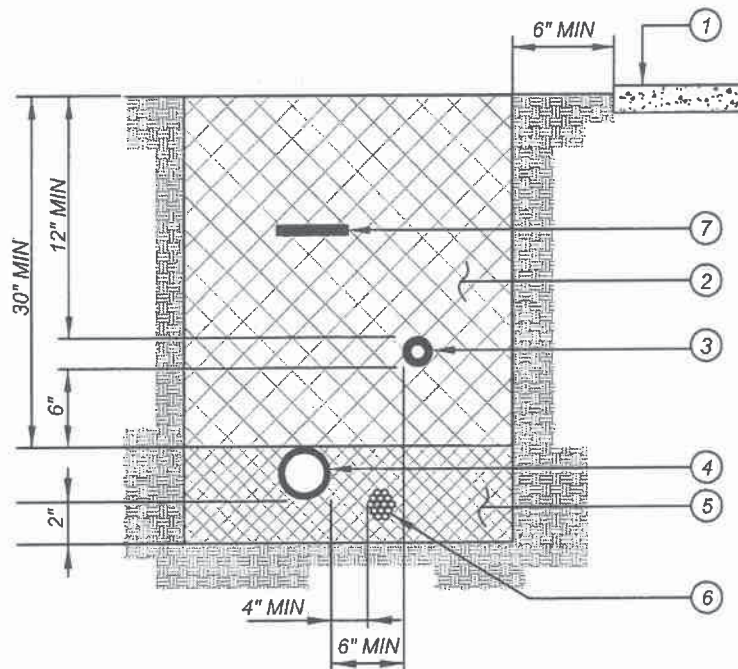





LEGEND:

- ① ADJACENT WALK OR FINISHED SURFACE
- ② CLEAN BACKFILL - SEE SPECIFICATIONS FOR MATERIAL, 90% COMPACTION REQUIRED
- ③ NON-PRESSURE LATERAL LINE
- ④ IRRIGATION MAIN LINE OR POTABLE WATER LINE
- ⑤ PROVIDE WASHED SAND BACKFILL
- ⑥ CONTROL WIRES - BUNDLE AND TAPE AT 8' OC AND INSTALL BELOW AND OFFSET FROM IRRIGATION MAIN LINE
- ⑦ DETECTABLE WARNING TAPE

NOTES:

- 1.) PIGTAIL AND/OR LOOP CONTROL WIRE AT ALL 90 DEGREE CHANGES IN DIRECTION
- 2.) SPLICING OF WIRE RUN PER CITY LANDSCAPE SPECIFICATIONS ONLY
- 3.) 30" MINIMUM COVER FOR RECLAIMED WATER MAINLINE

NOT TO SCALE

	RECOMMENDED:  DIVISION MANAGER	 DATE	CITY OF MORENO VALLEY PARKS AND COMMUNITY SERVICES DEPARTMENT	STANDARD PLAN MVLI-560B-0
	APPROVED:  PUBLIC WORKS DIRECTOR / DATE CITY ENGINEER	TRENCH DETAIL		SHEET 2 OF 2

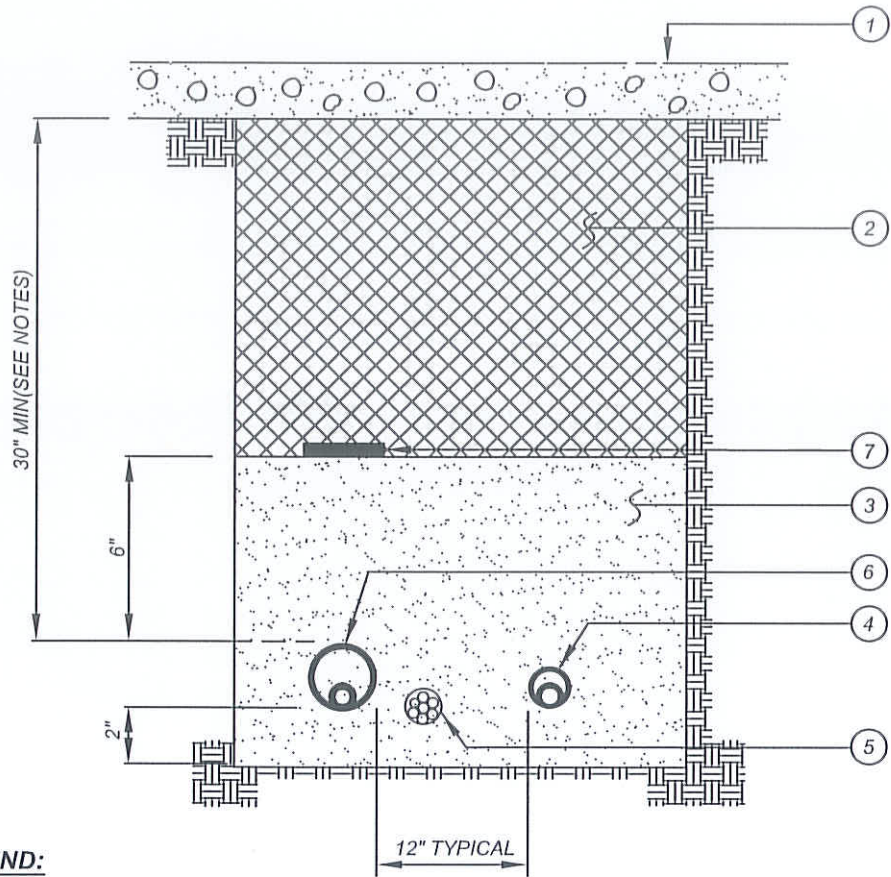



LEGEND:

- ① HARDSCAPING
- ② CLEAN BACKFILL - SEE SPECS. FOR MATERIAL, 90% COMPACTION REQUIRED
- ③ WASHED SAND
- ④ NON-PRESSURE LATERAL LINE SLEEVE SIZE TWICE DIAMETER OF NON-PRESSURE LATERAL LINE
- ⑤ CONTROL WIRE SLEEVE - SIZE PER PLAN, INSTALL ADJACENT TO IRRIGATION MAIN-LINE
- ⑥ IRRIGATION MAIN-LINE SLEEVE - SIZE TWICE DIAMETER OF IRRIGATION MAIN-LINE
- ⑦ WATER TAPE, 6" ABOVE WATER PIPE AND PER EMWD REQUIREMENTS

NOTES:

- 1) ALL SLEEVES TO BE SCH 40 PVC.
- 2) EXTEND ALL SLEEVES 12" BEYOND EDGE OF HARDSCAPE AT BOTH ENDS.
- 3) RECLAIMED WATER SLEEVING TO BE 30" DEPTH MINIMUM.

NOT TO SCALE

	RECOMMENDED:  <small>DIVISION MANAGER DATE</small>	<h2 style="margin: 0;">CITY OF MORENO VALLEY</h2> <p style="margin: 0;">FINANCIAL & MANAGEMENT SERVICES DEPARTMENT - SPECIAL DISTRICTS DIVISION</p>
	APPROVED:  <small>PUBLIC WORKS DIRECTOR / DATE</small> <small>CITY ENGINEER</small>	<h3 style="margin: 0;">SLEEVING DETAIL</h3>

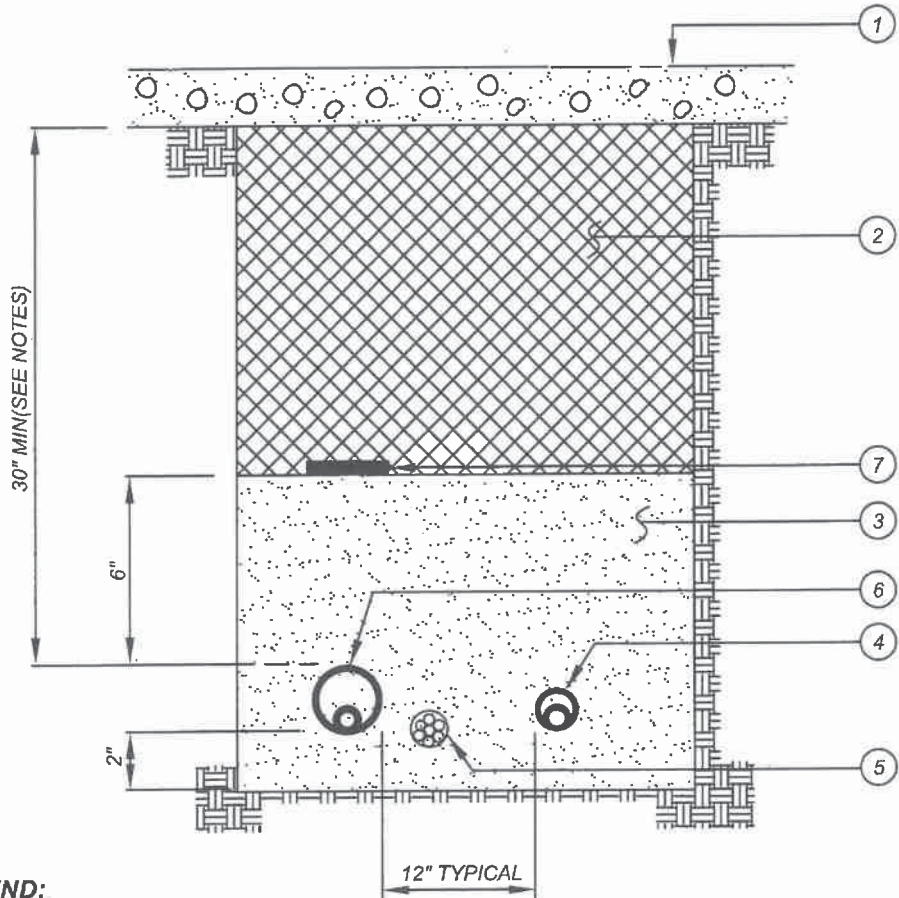



LEGEND:

- ① HARDSCAPING
- ② CLEAN BACKFILL - SEE SPECS. FOR MATERIAL, 90% COMPACTION REQUIRED
- ③ WASHED SAND
- ④ NON-PRESSURE LATERAL LINE SLEEVE SIZE TWICE DIAMETER OF NON-PRESSURE LATERAL LINE
- ⑤ CONTROL WIRE SLEEVE - SIZE PER PLAN, INSTALL ADJACENT TO IRRIGATION MAIN-LINE
- ⑥ IRRIGATION MAIN-LINE SLEEVE - SIZE TWICE DIAMETER OF IRRIGATION MAIN-LINE
- ⑦ DETECTABLE WATER TAPE, 6" ABOVE WATER PIPE AND PER EMWD REQUIREMENTS

NOTES:

- 1) ALL SLEEVES TO BE SCH 80 PVC.
- 2) EXTEND ALL SLEEVES 12" MINIMUM BEYOND EDGE OF HARDSCAPE AT BOTH ENDS PER LOCAL JURISDICTION.
- 3) RECLAIMED WATER SLEEVING TO BE 30" DEPTH MINIMUM.

NOT TO SCALE

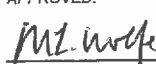
	RECOMMENDED:  DIVISION MANAGER DATE 6/20/19	<h2 style="margin: 0;">CITY OF MORENO VALLEY</h2> <p style="margin: 0;">PARKS AND COMMUNITY SERVICES DEPARTMENT</p>	STANDARD PLAN MVLI-561B-0
	APPROVED:  PUBLIC WORKS DIRECTOR / DATE 7/30/19 CITY ENGINEER	<h3 style="margin: 0;">SLEEVING DETAIL</h3>	

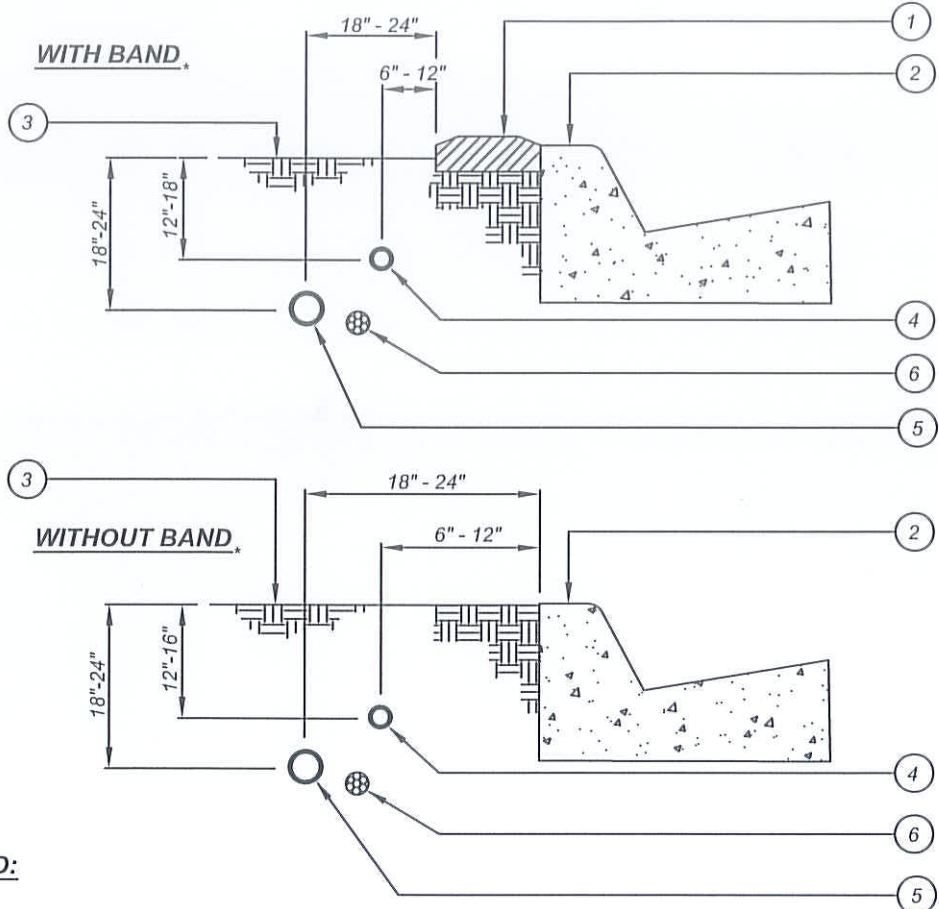

LEGEND:

- ① STAMPED CONCRETE, PAVER, ETC.
- ② CONC CURB
- ③ FINISH GRADE
- ④ LATERAL LINE LOCATION
- ⑤ MAIN LINE LOCATION
- ⑥ WIRE BUNDLE

NOTE:

- 1.) PIPES PLACED IN A COMMON TRENCH SHALL HAVE A VERTICAL & HORIZONTAL OFFSET OF 4" MINIMUM.
- * FOR MEDIANS LESS THEN 18' WIDE, HORIZONTAL OFFSET FROM CURB/HARDSCAPE SHALL BE AS DETERMINED BY CITY ENGINEER.

NOT TO SCALE

	RECOMMENDED:  1-16-14 DIVISION MANAGER DATE	CITY OF MORENO VALLEY FINANCIAL & MANAGEMENT SERVICES DEPARTMENT - SPECIAL DISTRICTS DIVISION	STANDARD PLAN
	APPROVED:  1/29/14 PUBLIC WORKS DIRECTOR / DATE CITY ENGINEER	MEDIAN AND PARKWAY IRRIGATION LINE INSTALLATION	MVLI-562-0
			SHEET 1 OF 1

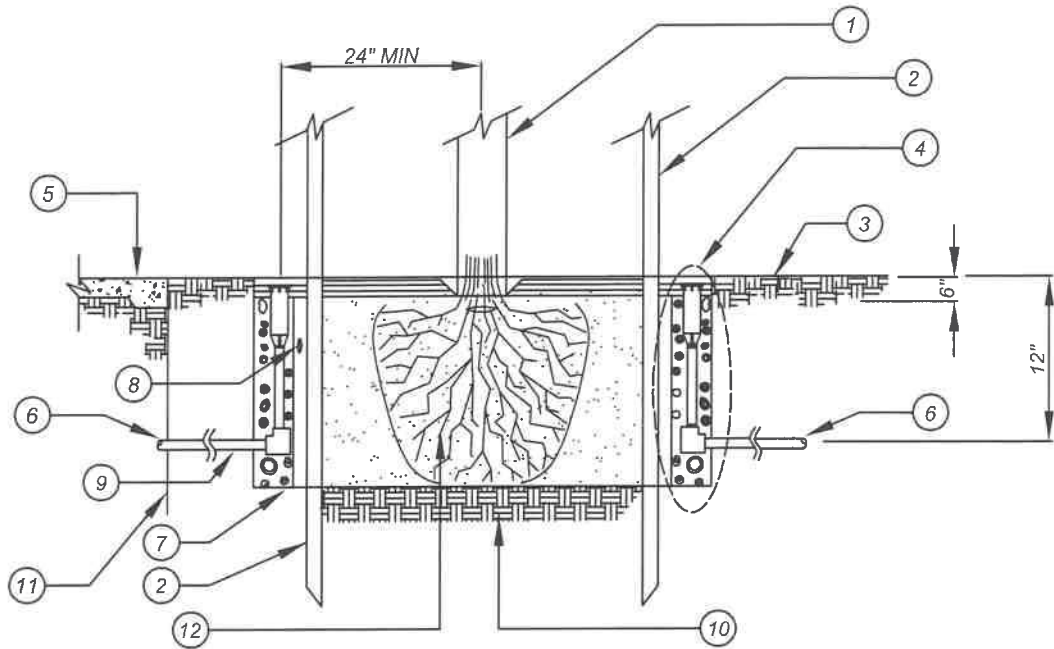



LEGEND:

- ① TREE TRUNK
- ② 2" LODGE POLE STAKES (PER CITY STANDARDS)
- ③ FINISH GRADE: TO BE DETERMINED AND APPROVED BY SPECIAL DISTRICTS IN THE FIELD
- ④ ROOT WATERING SYSTEM (RWS) (PER PLAN AS SPECIFIED), CONNECT TO LATERAL LINE PER MANUFACTURER'S RECOMMENDATIONS, AND AS APPROVED BY SPECIAL DISTRICTS. FILL WITH 1/2" AGGREGATE TO SPECIFIED LEVEL
- ⑤ CONCRETE SIDEWALK
- ⑥ NON-PRESSURE LATERAL LINE
- ⑦ PLANTING PIT: 2 TIMES WIDTH OF ROOTBALL AND SAME DEPTH AS ROOTBALL
- ⑧ PLANT TABLETS PER MANUFACTURER'S RECOMMENDATIONS (DISTRIBUTED AROUND ROOTBALL)
- ⑨ CONNECT TO LATERAL LINE PER MANUFACTURER'S RECOMMENDATIONS, AND AS APPROVED BY SPECIAL DISTRICTS
- ⑩ UNDISTURBED NATIVE SOIL
- ⑪ INSTALL VERTICAL ROOT BARRIER PER MFG. INSTRUCTIONS (WHERE SPECIFIED)
- ⑫ ROOTBALL

NOTES:

- 1) SUPPLEMENTAL TREE IRRIGATION: 1 RWS FOR 5 GALLON TREES. 2 RWS FOR 15 GALLON TREES AND LARGER.

NOT TO SCALE

	RECOMMENDED:  7/22/19 DIVISION MANAGER DATE	<h2 style="margin: 0;">CITY OF MORENO VALLEY</h2> <p style="margin: 0;">PUBLIC WORKS DEPARTMENT - SPECIAL DISTRICTS DIVISION</p>	
	APPROVED:  7/30/19 PUBLIC WORKS DIRECTOR / DATE CITY ENGINEER	<h3 style="margin: 0;">DEEP WELL TREE IRRIGATION</h3>	
			SHEET 1 OF 2

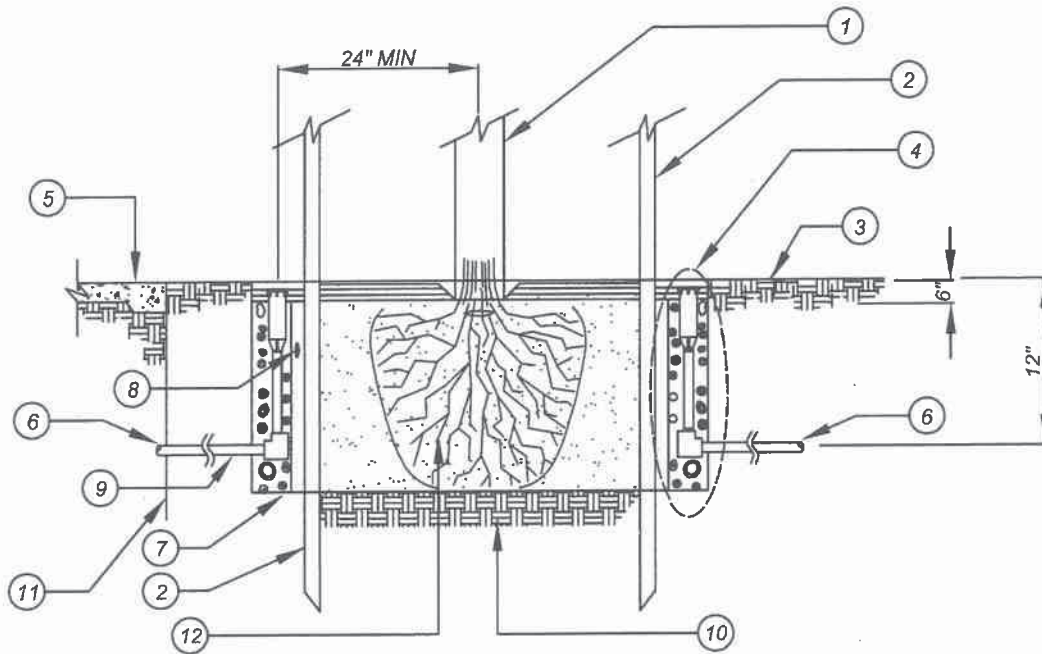

LEGEND:

- ① TREE TRUNK
- ② 2" LODGE POLE STAKES (PER CITY STANDARDS)
- ③ FINISH GRADE: TO BE DETERMINED AND APPROVED BY PARKS AND COMMUNITY SERVICES IN THE FIELD
- ④ ROOT WATERING SYSTEM (RWS) WITH MFG. DRAIN SOCK (PER PLAN AS SPECIFIED), CONNECT TO LATERAL LINE PER MANUFACTURER'S RECOMMENDATIONS, AND AS APPROVED BY PARKS AND COMMUNITY SERVICES. FILL WITH 3/4" AGGREGATE TO SPECIFIED LEVEL
- ⑤ CONCRETE SIDEWALK
- ⑥ NON-PRESSURE LATERAL LINE
- ⑦ PLANTING PIT: 2 TIMES WIDTH OF ROOTBALL AND SAME DEPTH AS ROOTBALL
- ⑧ PLANT TABLETS PER MANUFACTURER'S RECOMMENDATIONS (DISTRIBUTED AROUND ROOTBALL)
- ⑨ CONNECT TO LATERAL LINE PER MANUFACTURER'S RECOMMENDATIONS, AND AS APPROVED BY PARKS AND COMMUNITY SERVICES
- ⑩ UNDISTURBED NATIVE SOIL
- ⑪ INSTALL VERTICAL ROOT BARRIER PER MFG. INSTRUCTIONS (WHERE SPECIFIED)
- ⑫ ROOTBALL

NOTES:

- 1) SUPPLEMENTAL TREE IRRIGATION: 3 RWS FOR 15 GALLON TREES AND LARGER.

NOT TO SCALE



RECOMMENDED:
[Signature]
 DIVISION MANAGER
 DATE: 6/20/19

APPROVED:
[Signature]
 PUBLIC WORKS DIRECTOR / CITY ENGINEER
 DATE: 7/30/19

CITY OF MORENO VALLEY
 PARKS AND COMMUNITY SERVICES DEPARTMENT

DEEP WELL TREE IRRIGATION

STANDARD PLAN
MVLI-563B-0

SHEET 2 OF 2

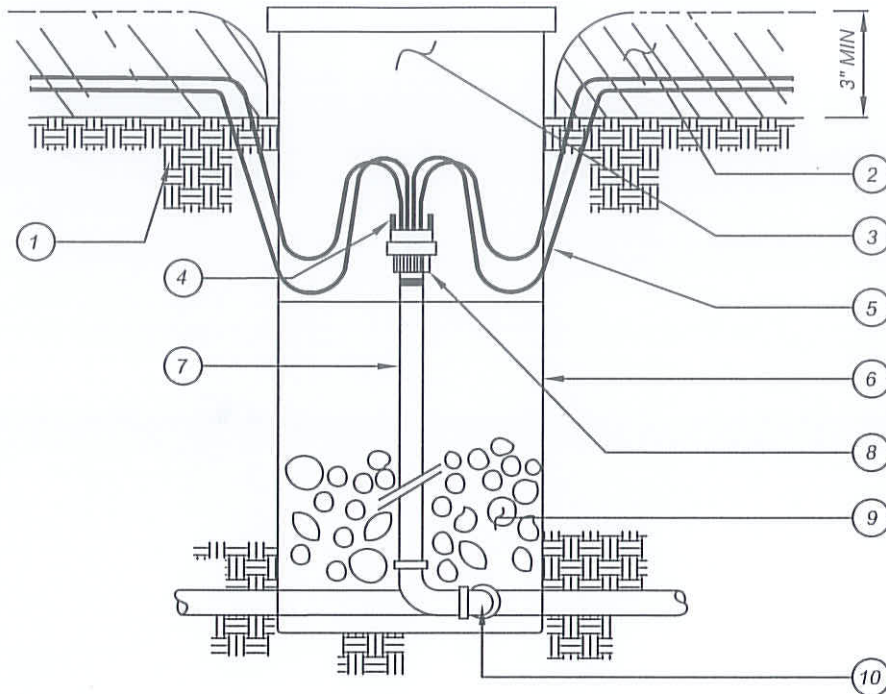



LEGEND:

- ① FINISH GRADE
- ② MEDIUM GRIND SHREDDED MULCH COVER OVER DIST. TUBES -IN PLANTER BEDS
- ③ VALVE BOX 3" ABOVE FINISH GRADE
- ④ EMITTER OUTLET - CAP/PLUG UNUSED OUTLETS IF NECESSARY
- ⑤ DISTRIBUTION TUBES WITH OUTLET CHECK VALVE CAPS. (MIN 2 PER SHRUB) INSTALL WITH PLASTIC TUBE STAKES.
- ⑥ 10" PLASTIC VALVE BOX BRANDED "EMT" ON LID
- ⑦ 1/2" DIA SCH 80 PVC NIPPLE LENGTH AS REQUIRED
- ⑧ MULTI-OUTLET EMITTER WITH THREADED RISER ADAPTER, (1 PER 2 OR 3 SHRUBS).
1 EMITTER FOR 5 GALLON TREES AND 2 EMITTERS PER 15 GALLON AND LARGER TREES.
- ⑨ 3/8" WASHED AGGREGATE. LEAVE SPACE BETWEEN EMITTER AND TOP OF AGGREGATE.
- ⑩ MARLEX DOUBLE STREET ELLS BETWEEN LATERAL LINE AND RISER.

NOTES:

- 1) INSTALL TWO MULTI EMITTERS 18" FROM TRUNK OF EVERY TREE (DO NOT USE DISTRIBUTION TUBING).
- 2) INSTALL ONE MULTI EMITTER PER SIX GROUND COVER PLANTS (ONE DISTRIBUTION TUBE PER PLANT).

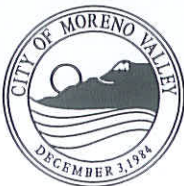
NOT TO SCALE

	RECOMMENDED:  1.16.14 DIVISION MANAGER DATE	<h2 style="margin: 0;">CITY OF MORENO VALLEY</h2> <p style="margin: 0;">FINANCIAL & MANAGEMENT SERVICES DEPARTMENT - SPECIAL DISTRICTS DIVISION</p>	STANDARD PLAN MVLI-564-0
	APPROVED:  1/29/14 PUBLIC WORKS DIRECTOR / DATE CITY ENGINEER	<h3 style="margin: 0;">DRIP EMITTER INSTALLATION</h3>	

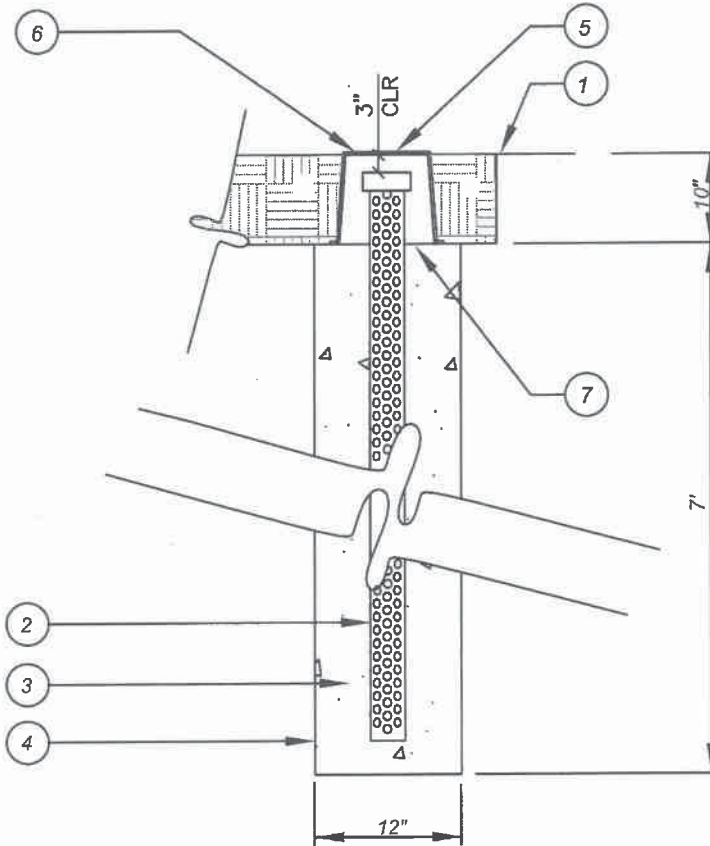

LEGEND

- ① FINISHED GRADE
- ② 4" PERFORATED PIPE W/ DRAIN SOCK AND CAP AT TOP. ADD HOLES OPPOSITE SIDE.
- ③ 3/4" CRUSHED AGGREGATE (3/4" MIN, NO FINES)
- ④ SPUN BOUND FILTER WRAP FABRIC
- ⑤ 10" ROUND BOX WITH SS BOLT & CLIP
- ⑥ 2" HEAT STAMP "SUMP"
- ⑦ 1/4" STAINLESS STEEL WIRE MESH, TYPE 316

NOT TO SCALE

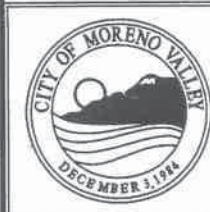

RECOMMENDED
[Signature] 6/20/19
 DIVISION MANAGER DATE
 APPROVED:
M. W. W. 7/30/19
 PUBLIC WORKS DIRECTOR / DATE
 CITY ENGINEER

CITY OF MORENO VALLEY
 PARKS AND COMMUNITY SERVICES DEPARTMENT

TREE WELL SUMP

STANDARD PLAN
MVLI-565-0

SHEET 1 OF 1

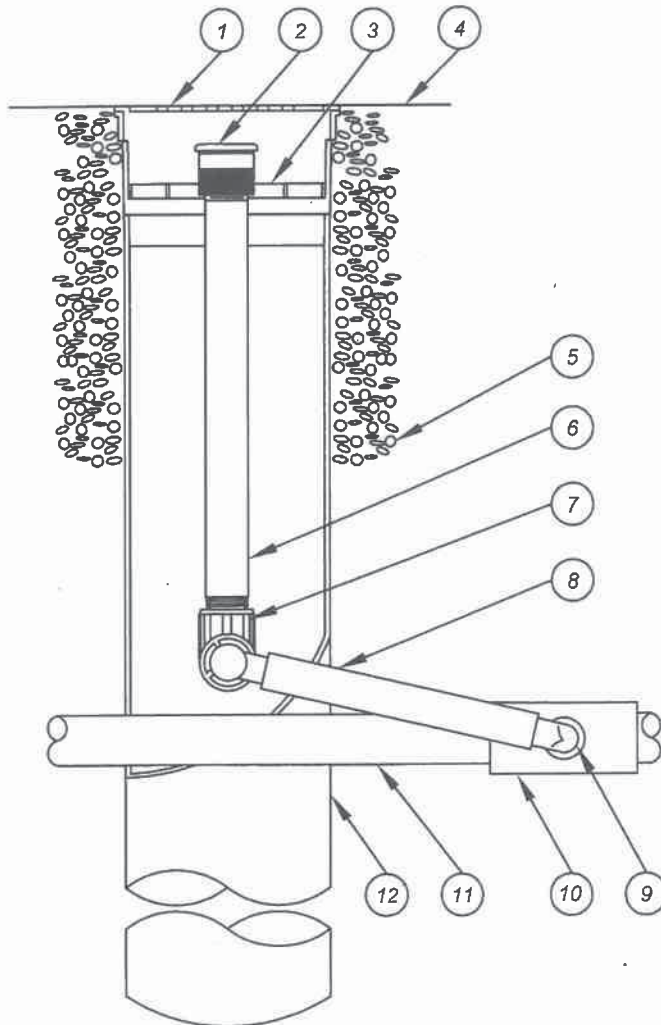

- 1 4-INCH GRATE (INCLUDED)
- 2 BUBBLER: RAIN BIRD 1402 0.50 GPM OR AS REQUESTED (INCLUDED)
- 3 ROOT WATERING SYSTEM: RAIN BIRD RWS-BCG02 OR AS SPECIFIED (INCLUDES 1402 0.50 GPM BUBBLER WITH RISER, GRATE, SWING ASSEMBLY, 1/2" MALE NPT INLET, CHECK VALVE, AND BASKET CANISTER)
- 4 FINISH GRADE
- 5 3/4" ROCK AND RWS SAND SOCK (RWS-SOCK)
- 6 1/2-INCH PVC SCH 80 NIPPLE (INCLUDED)
- 7 1/2-INCH 90-DEGREE ELBOW (INCLUDED)
- 8 12-INCH SWING ASSEMBLY (INCLUDED)
- 9 1/2-INCH MALE NPT INLET (INCLUDED)
- 10 PVC SCH 40 TEE OR ELL
- 11 LATERAL PIPE
- 12 4-INCH BASKET WEAVE CANISTER (INCLUDED)

NOT TO SCALE

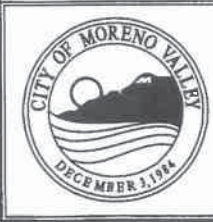

RECOMMENDED: *[Signature]* 6/20/19
 DIVISION MANAGER DATE
 APPROVED: *[Signature]* 7/30/19
 PUBLIC WORKS DIRECTOR / DATE
 CITY ENGINEER

CITY OF MORENO VALLEY
 PARKS AND COMMUNITY SERVICES DEPARTMENT

**RAINBIRD RWS - BCG02
 ROOT WATERING SYSTEM**

STANDARD PLAN
MVLI-566-0
 SHEET 1 OF 1

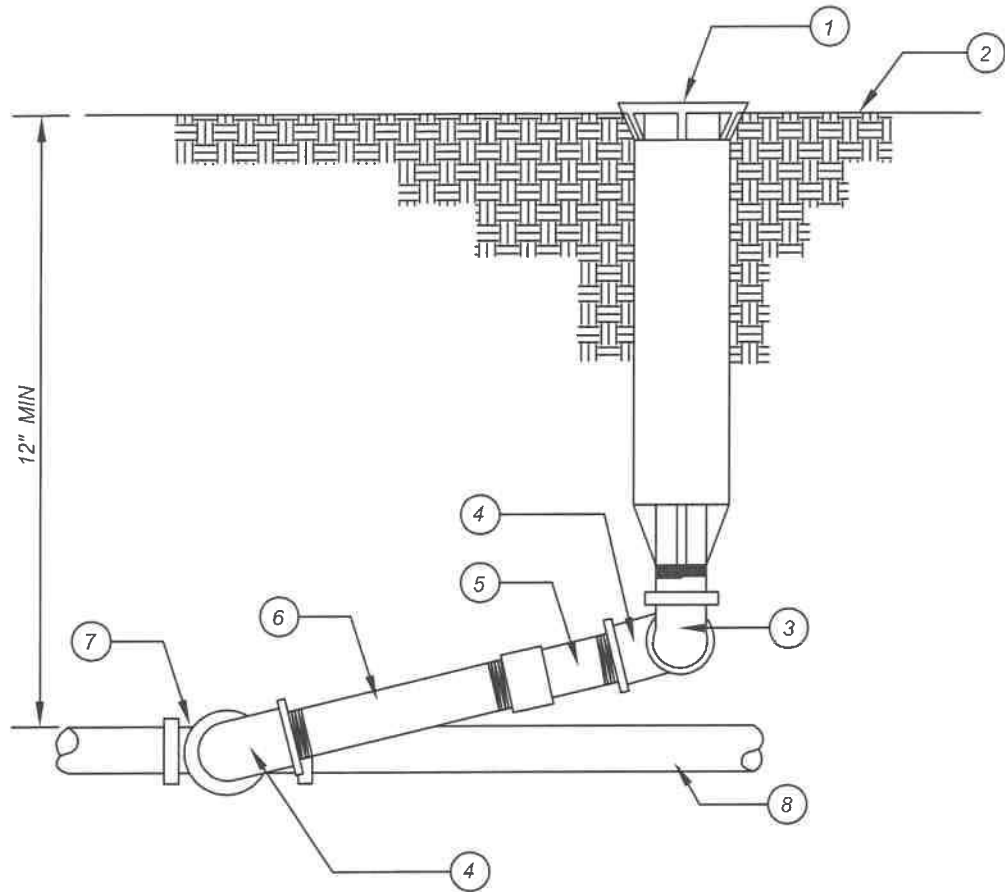

LEGEND:

- ① POP-UP HEAD
- ② FINISH GRADE
- ③ SCH 40 PVC 90 DEGREE STREET ELL (MIPT x FIPT)
- ④ MARLEX 90 DEGREE STREET ELL (MIPT x FIPT)
- ⑤ ANTI-DRAIN VALVE-ALL DOWN SLOPE HEADS-IF NOT INSTALLED IN HEADS
- ⑥ SCH 80 PVC NIPPLE (6" LONG)
- ⑦ SCH 40 PVC TEE (S x S x T TEE OR S x T 90° ELL)
- ⑧ NON-PRESSURE LATERAL LINE

NOTES:

- 1) LOCATE HEAD 4" FROM HARDSCAPING IN TURF AREAS - 8" MINIMUM IN PLANTER AREAS. (THESE MINIMUMS MAY BE INCREASED PER SPECIFICATIONS).
- 2) USE TEFLON TAPE ON ALL MALE THREADS.

NOT TO SCALE

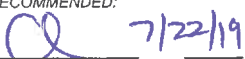
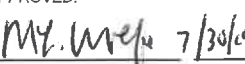
	RECOMMENDED:  DIVISION MANAGER DATE	<h2 style="margin: 0;">CITY OF MORENO VALLEY</h2> <p style="margin: 0;">PUBLIC WORKS DEPARTMENT - SPECIAL DISTRICTS DIVISION</p>	STANDARD PLAN <h3 style="margin: 0;">MVLI-570A-0</h3>
	APPROVED:  PUBLIC WORKS DIRECTOR / DATE CITY ENGINEER	<h3 style="margin: 0;">6" POP-UP SPRAY HEAD</h3>	SHEET 1 OF 3

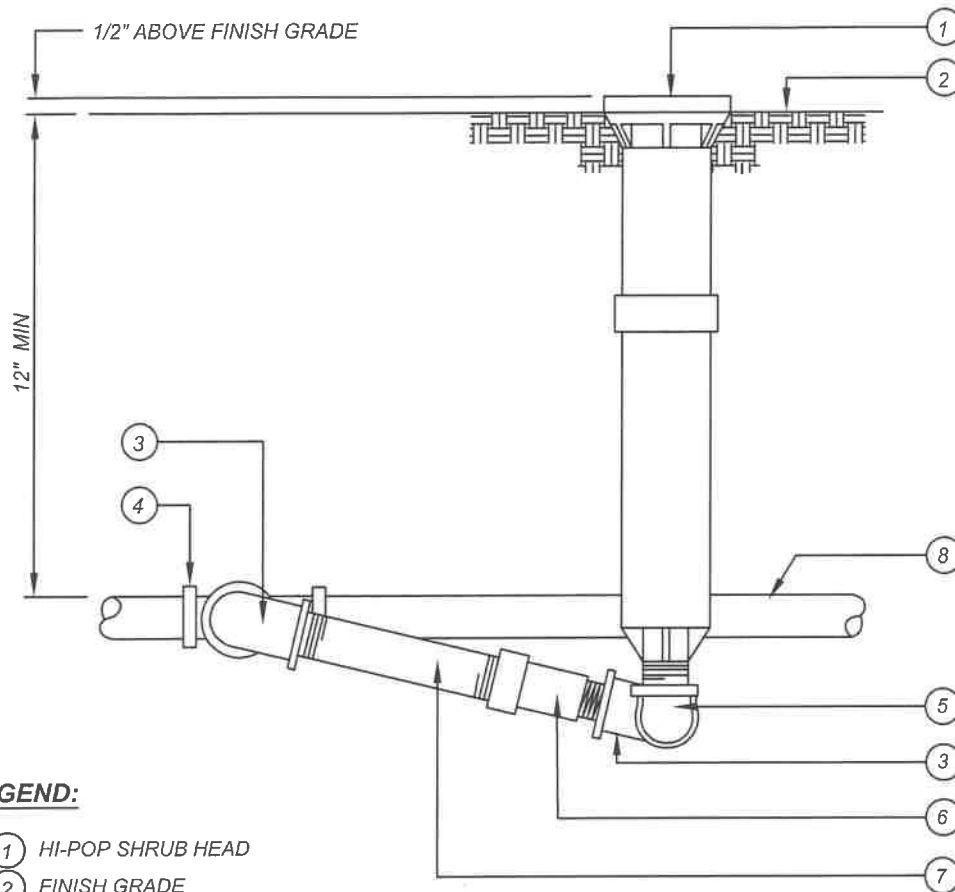



LEGEND:

- ① HI-POP SHRUB HEAD
- ② FINISH GRADE
- ③ MARLEX 90 DEGREE STREET ELL
- ④ SCH 40 PVC TEE (S x S x T)
- ⑤ SCH 40 PVC 90 DEGREE STREET ELL (MIPT x FIPT)
- ⑥ ANTI-DRAIN VALVE-ALL DOWN SLOPE HEADS-IF NOT INSTALLED IN HEAD
- ⑦ SCH 80 PVC NIPPLE - 12" LONG
- ⑧ NON-PRESSURE LATERAL LINE

NOTES:

- 1) LOCATE HEAD 4" FROM HARDSCAPING IN TURF AREAS - 8" MINIMUM IN PLANTER AREAS. (THESE MINIMUMS MAY BE INCREASED PER SPEC.)
- 2) USE TEFLON TAPE ON ALL MALE THREADS.

NOT TO SCALE

	RECOMMENDED:  7/22/19 DIVISION MANAGER DATE	CITY OF MORENO VALLEY PUBLIC WORKS DEPARTMENT - SPECIAL DISTRICTS DIVISION	
	APPROVED:  7/30/19 PUBLIC WORKS DIRECTOR / DATE CITY ENGINEER	12" POP-UP SPRAY HEAD	

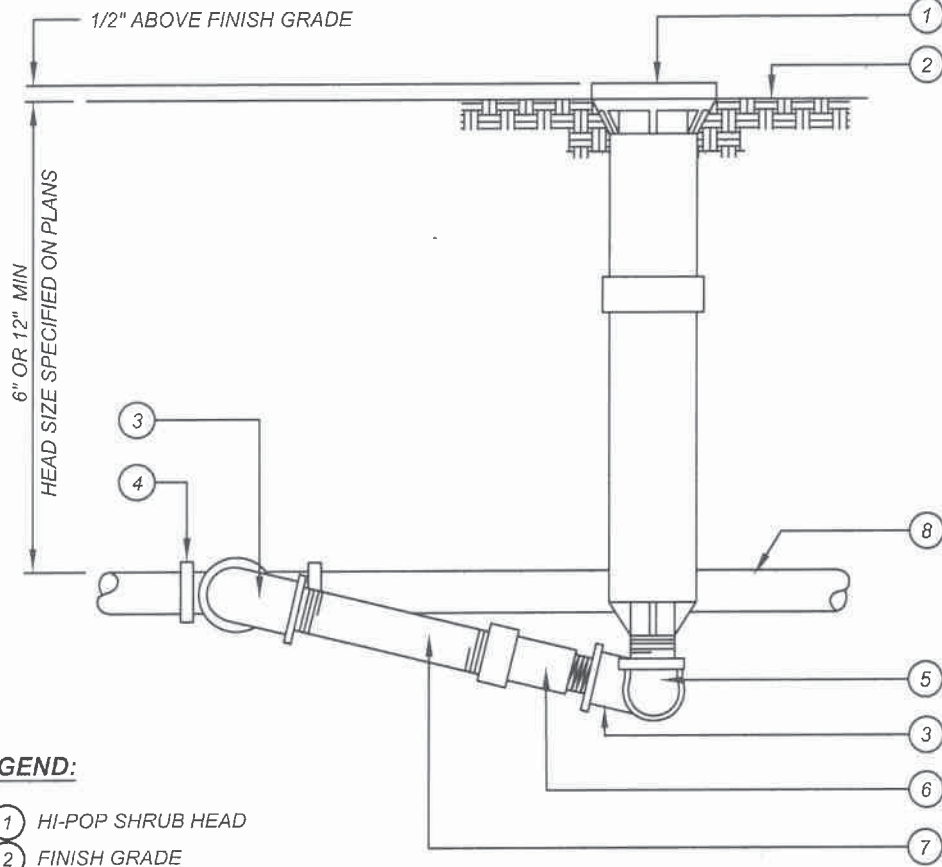

LEGEND:

- 1 HI-POP SHRUB HEAD
- 2 FINISH GRADE
- 3 MARLEX 90 DEGREE STREET ELL
- 4 SCH 40 PVC TEE (S x S x T)
- 5 SCH 40 PVC 90 DEGREE STREET ELL (MIPT x FIPT)
- 6 ANTI-DRAIN VALVE-ALL DOWN SLOPE HEADS - IF NOT INSTALLED IN HEAD
- 7 SCH 80 PVC NIPPLE - LENGTH EQUAL TO SPRINKLER HEIGHT
- 8 NON-PRESSURE LATERAL LINE

NOTES:

- 1) LOCATE HEAD 2" FROM HARDSCAPING IN TURF AREAS - 4" MINIMUM IN PLANTER AREAS (THESE MINIMUMS MAY BE INCREASED PER SPEC.)
- 2) USE TEFLON TAPE ON ALL MALE THREADS
- 3) PRE-MANUFACTURED SWING ASSEMBLIES MAY BE SUBSTITUTED WITH AGENCY APPROVAL

NOT TO SCALE

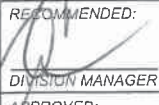
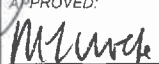

RECOMMENDED:

 DIVISION MANAGER DATE 9/26/19
 APPROVED:

 PUBLIC WORKS DIRECTOR / DATE 10/11/19
 CITY ENGINEER

CITY OF MORENO VALLEY
 PARKS AND COMMUNITY SERVICES DEPARTMENT

6" OR 12" POP-UP SPRAY HEAD

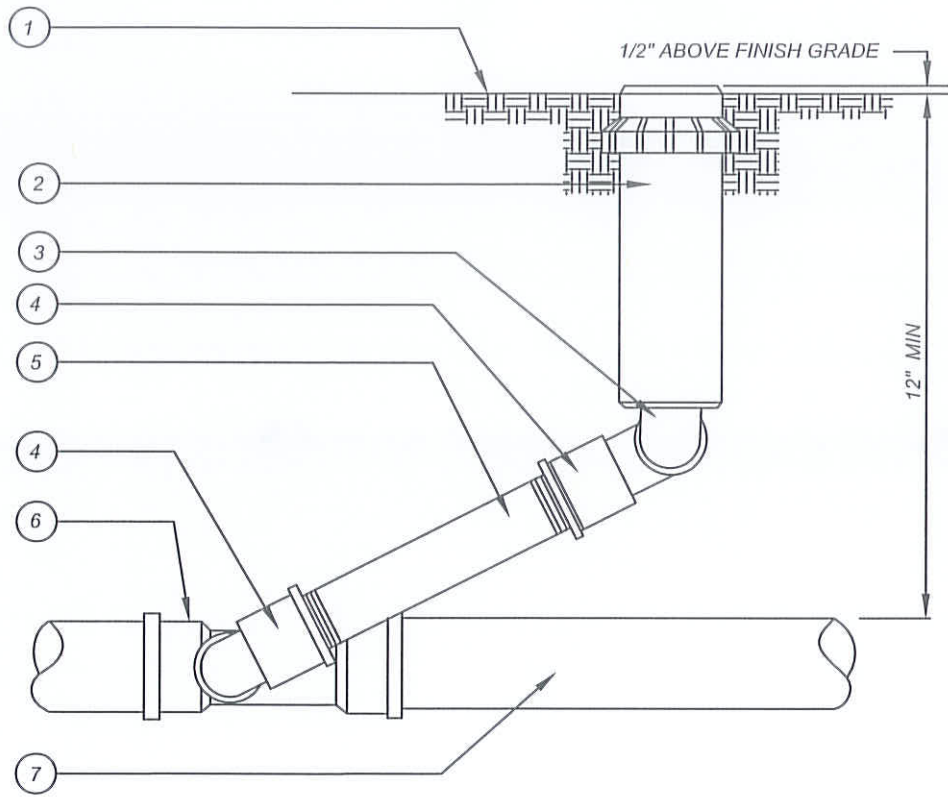
STANDARD PLAN
MVLI-570C-0

SHEET 3 OF 3





LEGEND:

- ① FINISH GRADE
- ② POP-UP GEARED ROTOR W/INTERNAL ANTI-DRAIN VALVES
- ③ 3/4" SCH 40 PVC 90 DEGREE STREET ELL (MIPT x FIPT)
- ④ 3/4" MARLEX 90 DEGREE STREET ELL (MIPT x FIPT)
- ⑤ 3/4" SCH 80 NIPPLE (LENGTH AS REQUIRED)
- ⑥ SCH 40 PVC TEE (S x S x T)
- ⑦ NON-PRESSURE LATERAL LINE

NOTES:

- 1) USE 12" HIGH-POPS IN SHRUB AREAS.
- 2) ALIGN HEADS PERPENDICULAR WITH ANGLE OF SLOPE.
- 3) ADD ANTI-DRAIN VALVES ON 3/4" NIPPLE ON DOWN SLOPE ROTORS IF NOT FITTED IN HEAD BY MFG.
- 4) LOCATE HEAD 6" FROM HARDSCAPE IN TURF AREAS - 12" IN PLANTER AREAS.
(THESE MINIMUMS MAY BE INCREASED PER SPECIFICATIONS).

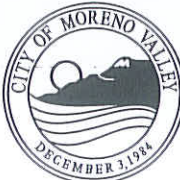
NOT TO SCALE

	RECOMMENDED:  1-16-14 DIVISION MANAGER DATE	<h2 style="margin: 0;">CITY OF MORENO VALLEY</h2> <p style="margin: 0;">FINANCIAL & MANAGEMENT SERVICES DEPARTMENT - SPECIAL DISTRICTS DIVISION</p>	STANDARD PLAN
	APPROVED:  1/29/14 PUBLIC WORKS DIRECTOR / DATE / CITY ENGINEER	<h3 style="margin: 0;">POP-UP ROTARY HEAD</h3>	<h3 style="margin: 0;">MVLI-571A-0</h3>
	SHEET 1 OF 2		

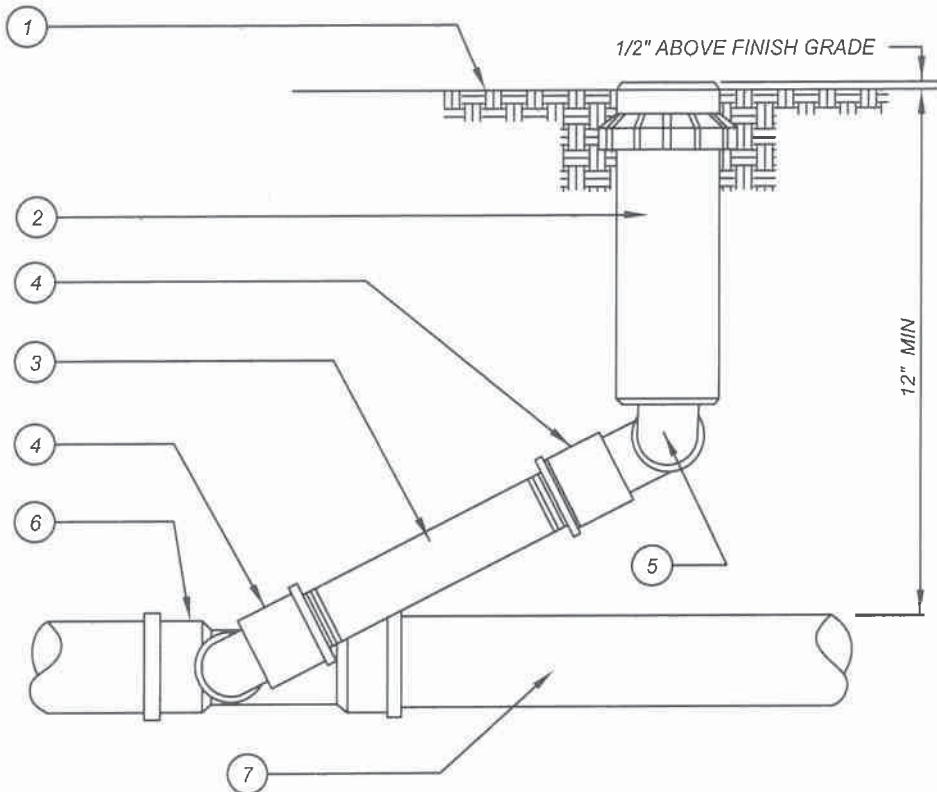



LEGEND:

- 1) FINISH GRADE
- 2) POP-UP GEARED ROTOR W/INTERNAL ANTI-DRAIN VALVES. SS RISERS ARE REQUIRED ON ROTORS UNDER 12"
- 3) SCH 80 PVC NIPPLE - LENGTH EQUAL TO ROTOR HEIGHT
- 4) MARLEX 90 DEGREE STREET ELL
- 5) SCH 40 90 DEGREE STREET ELL
- 6) SCH 40 PVC TEE (S x S x T)
- 7) NON-PRESSURE LATERAL LINE

NOTES:

- 1) USE 12" HIGH-POPS IN SHRUB AREAS
- 2) ALIGN HEADS PERPENDICULAR WITH ANGLE OF SLOPE
- 3) LOCATE HEAD 2" FROM HARDSCAPE IN TURF AREAS - 6" IN PLANTER AREAS
(THESE MINIMUMS MAY BE INCREASED PER SPECIFICATIONS)
- 4) USE TEFLON TAPE ON ALL MALE THREADS
- 5) PRE-MANUFACTURED SWING ASSEMBLIES MAY BE SUBMITTED WITH AGENCY APPROVAL

NOT TO SCALE

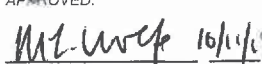
	RECOMMENDED:  DIVISION MANAGER	CITY OF MORENO VALLEY PARKS AND COMMUNITY SERVICES DEPARTMENT	STANDARD PLAN
	APPROVED:  PUBLIC WORKS DIRECTOR / DATE CITY ENGINEER		POP-UP ROTARY HEAD
			MVLI-571B-0 SHEET 2 OF 2

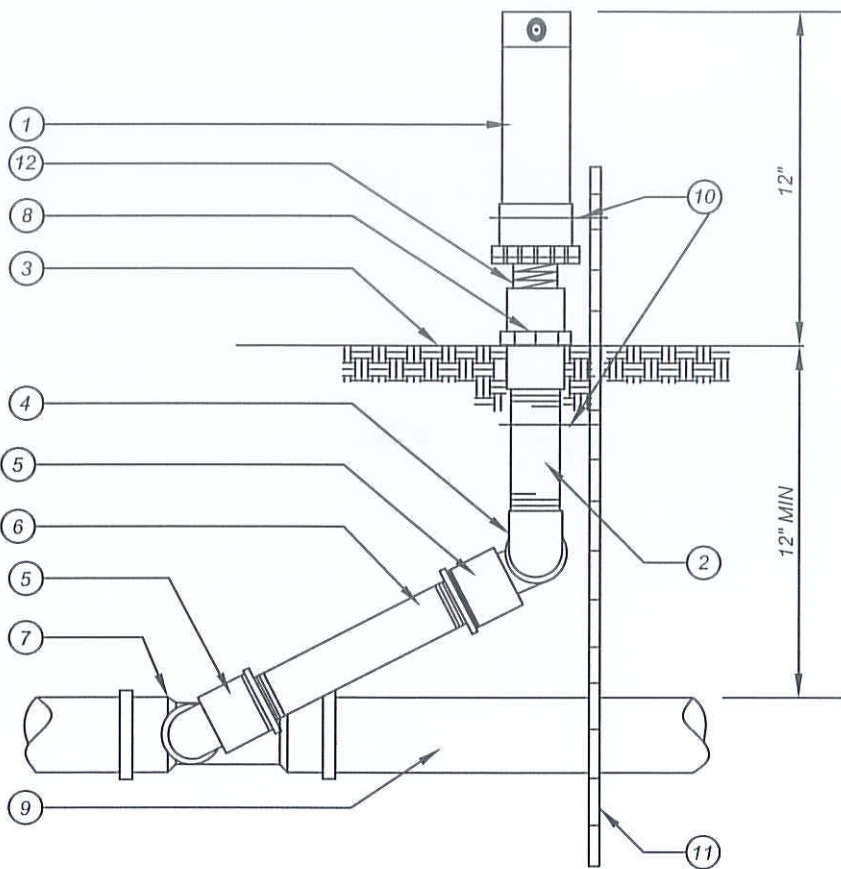

LEGEND:

- ① GEARED SHRUB ROTOR
- ② SCH 80 3/4" PVC RISER (LENGTH AS REQUIRED) (REBAR STAKED WITH 2 STAINLESS STEEL CLAMPS IF 6" OR MORE EXPOSURE)
- ③ FINISH GRADE (ALIGN HEAD PERPENDICULAR WITH ANGLE OF SLOPE)
- ④ 3/4" SCH 40 PVC 90 DEGREE ELL (FIPT X FIPT)
- ⑤ 3/4" MARLEX 90 DEGREE STREET ELL (MIPT X FIPT)
- ⑥ 3/4" x 8" SCH 80 NIPPLE
- ⑦ SCH 40 PVC TEE (S x S x T)
- ⑧ ANTI DRAIN VALVE ON DOWN SLOPE ROTORS IF NOT FITTED IN BY MFG.
- ⑨ NON-PRESSURE LATERAL LINE
- ⑩ STAINLESS STEEL SCREW, CLAMP MIN. (2) PLACES
- ⑪ No 4 REBAR STAKE (24" LONG)
- ⑫ SCH 80 CLOSE NIPPLE

NOT TO SCALE

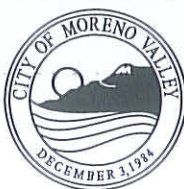

RECOMMENDED:
 COS 1-16-14
 DIVISION MANAGER DATE

APPROVED:
 [Signature] 1/29/14
 PUBLIC WORKS DIRECTOR / DATE
 CITY ENGINEER

CITY OF MORENO VALLEY
 FINANCIAL & MANAGEMENT SERVICES DEPARTMENT - SPECIAL DISTRICTS DIVISION

**ROTOR INSTALLATION ON
 FIXED RISER**

STANDARD PLAN
MVLI-572-0

SHEET 1 OF 1

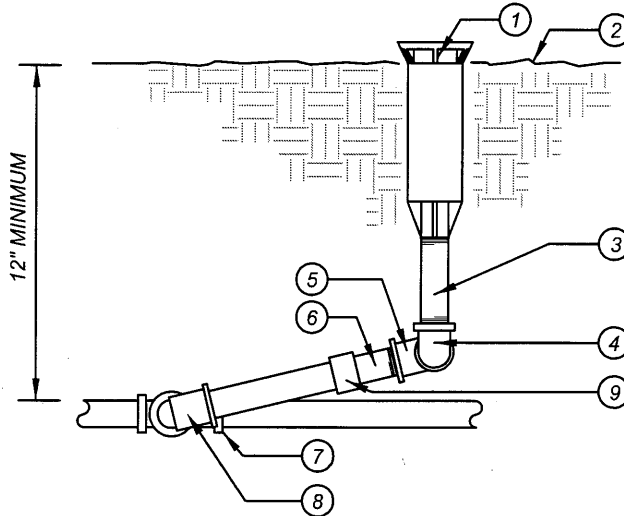



LEGEND:

- ① RAINBIRD 1800 SAM-PRS POP -UP HEAD WITH PURPLE RUBBER COVER (AS REQUIRED) 2" ABOVE GRADE IN SHRUB AREAS & 1" ABOVE GRADE IN TURF. RECLAIMED WATER SYSTEMS REQUIRE INTEGRATED PURPLE BODY CAP (NO PURPLE COVERS).
- ② FINISH GRADE
- ③ SCH 80 PVC NIPPLE LENGTH AS NECESSARY
- ④ SCH 40 PVC T x T 90 DEGREE ELBOW
- ⑤ MARLEX 90 DEGREE STREET ELBOW
- ⑥ SCH 80 PVC NIPPLE (6" LONG)
- ⑦ NON-PRESSURE LATERAL LINE & TEE FITTING
- ⑧ MARLEX 90 DEGREE ELBOW
- ⑨ ANTI-DRAIN VALVE-ALL DOWN SLOPE HEADS

NOTES:

- 1.) LOCATE HEAD 2" FROM WALKS, CURBS, HARDSCAPING, MOW STRIPS.
- 2.) LOCATE HEAD 6" FROM ALL STRUCTURES.
- 3.) USE TEFLON TAPE ON ALL MALE THREADS.
- 4.) PRE-MOLDED SWING JOINTS MAY BE USED UPON APPROVAL.
- 5.) FLEX PIPE MAY BE UTILIZED AS SWING ASSEMBLY.

NOT TO SCALE

	RECOMMENDED:  DIVISION MANAGER DATE	<h2 style="margin: 0;">CITY OF MORENO VALLEY</h2> <p style="margin: 0;">PARKS AND COMMUNITY SERVICES DEPARTMENT</p> <h3 style="margin: 0;">RAINBIRD 1800 SAM PRS POP UP SPRAY HEAD</h3>	STANDARD PLAN MVLI-573-0
	APPROVED:  PUBLIC WORKS DIRECTOR / DATE CITY ENGINEER		SHEET 1 OF 1

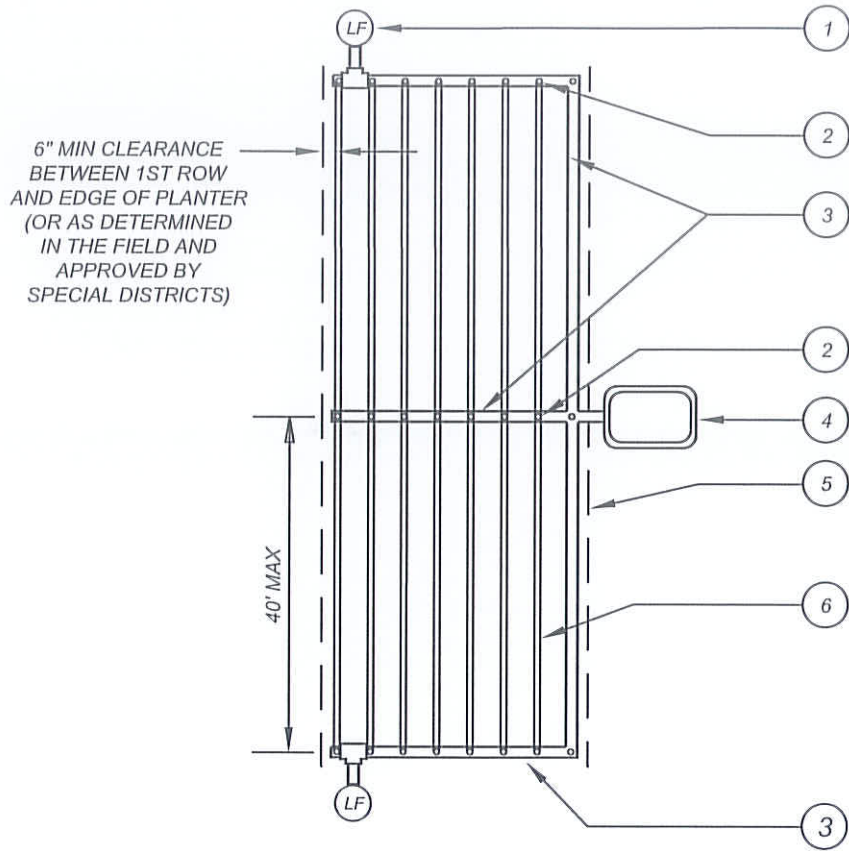

- ① MANUAL SHUT-OFF VALVE (REFER TO STANDARD MVLI-574G-0)
- ② DRIPPERLINE TO PVC CONNECTION (REFER TO STANDARD MVLI-574E-0)
- ③ LATERAL LINE (BURIED 12" MIN)
- ④ REMOTE CONTROL VALVE WITH FILTER AND PRESSURE REGULATING VALVE (REFER TO PLANS)
- ⑤ AREA PERIMETER
- ⑥ DRIPPERLINE TUBING LATERAL - BURIED 3" - 4" (SPACING AS SPECIFIED ON PLANS)

NOTES:

- 1.) SOIL STAPLE DRIPPERLINE TUBING AT 3' OC WITH NETAFIM TLS6.
- 2.) REFER TO STANDARD MVLI-574E-0 FOR DRIPPERLINE AND BELOW GROUND PVC CONNECTION.
- 3.) REFER TO STANDARD MVLI-574G-0 FOR MANUAL SHUT-OFF/FLUSH VALVE.

NOT TO SCALE

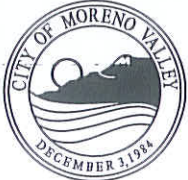
	RECOMMENDED: <i>COS</i> 1/16/14 <small>DIVISION MANAGER DATE</small>	<h2 style="margin: 0;">CITY OF MORENO VALLEY</h2> <p style="margin: 0;">FINANCIAL & MANAGEMENT SERVICES DEPARTMENT - SPECIAL DISTRICTS DIVISION</p>	<small>STANDARD PLAN</small> MVLI-574A-0
	APPROVED: <i>[Signature]</i> 1/29/14 <small>PUBLIC WORKS DIRECTOR / DATE</small> <small>CITY ENGINEER</small>	<h3 style="margin: 0;">DRIPPERLINE (WITH INTEGRATED CHECK VALVES) CENTER FEED LAYOUT</h3>	

6" MIN CLEARANCE
BETWEEN 1ST ROW
AND EDGE OF PLANTER
(OR AS DETERMINED
IN THE FIELD AND
APPROVED BY
PARKS AND
COMMUNITY SERVICES)

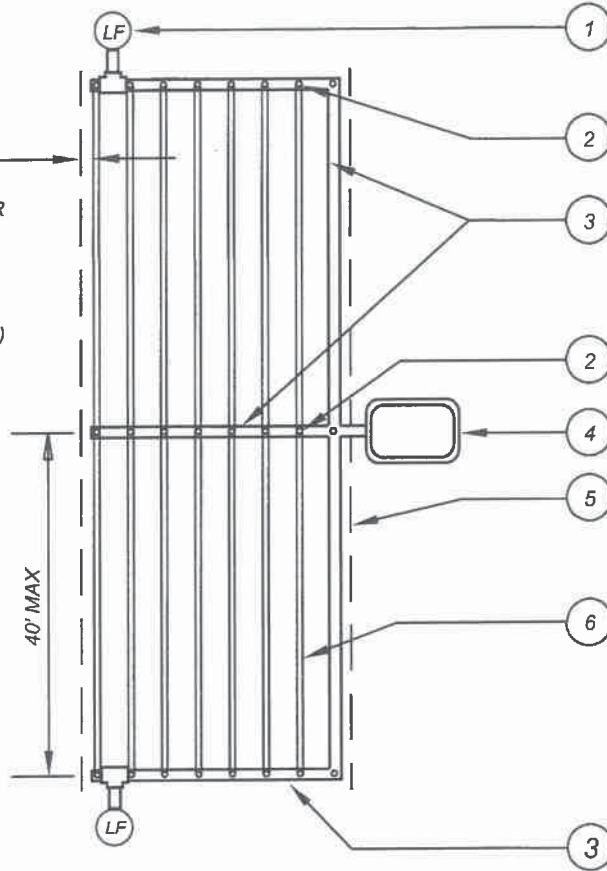

- 1) MANUAL SHUT-OFF VALVE (REFER TO STANDARD MVLI-574H)
- 2) DRIPPERLINE TO PVC CONNECTION (REFER TO STANDARD MVLI-574F) OR MANUFACTURER'S PRE-MADE DRIPLINE HEADER
- 3) LATERAL LINE (BURIED 12" MIN)
- 4) REMOTE CONTROL VALVE WITH T58S-70-76 BALL VALVE, FILTER AND PRESSURE REGULATING VALVE (REFER TO PLANS)
- 5) AREA PERIMETER
- 6) DRIPPERLINE TUBING LATERAL (AS SPECIFIED) - BURIED 2" (SPACING AS SPECIFIED ON PLANS)

NOTES:

- 1.) SOIL STAPLE DRIPPERLINE TUBING AT 3' OC WITH RAINBIRD STAKE WITH BEND
- 2.) REFER TO STANDARD MVLI-574F-0 FOR DRIPPERLINE AND BELOW GROUND PVC CONNECTION
- 3.) REFER TO STANDARD MVLI-574H-0 FOR MANUAL SHUT-OFF/FLUSH VALVE

NOT TO SCALE

	RECOMMENDED:  DIVISION MANAGER	 DATE	<h2 style="margin: 0;">CITY OF MORENO VALLEY</h2> <p style="margin: 0;">PARKS AND COMMUNITY SERVICES DEPARTMENT</p>	STANDARD PLAN <h3 style="margin: 0;">MVLI-574B-0</h3>
	APPROVED:  PUBLIC WORKS DIRECTOR / DATE CITY ENGINEER	<h3 style="margin: 0;">DRIPPERLINE (WITH INTEGRATED CHECK VALVES) CENTER FEED LAYOUT</h3>		SHEET 2 OF 12

6" MIN CLEARANCE
BETWEEN 1ST ROW
AND EDGE OF PLANTER
(OR AS DETERMINED
IN THE FIELD AND
APPROVED BY
SPECIAL DISTRICTS)

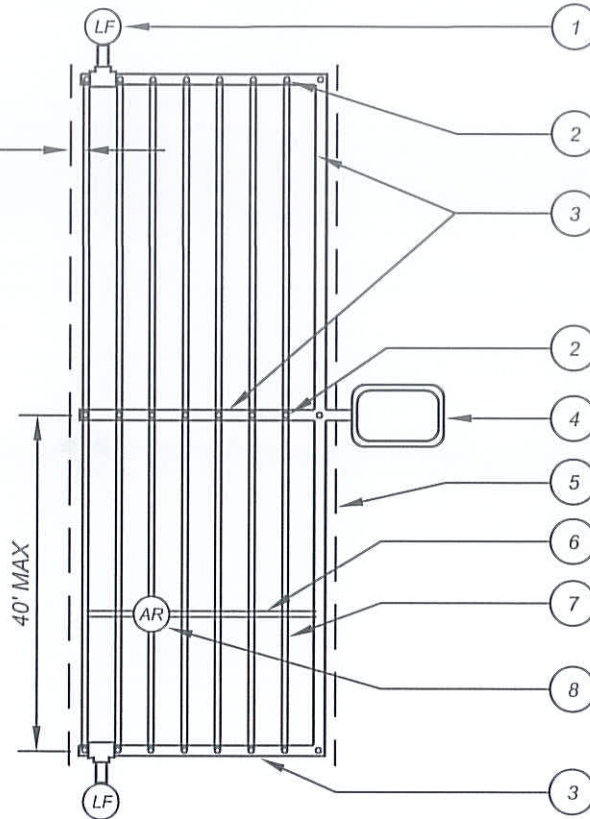



- ① AUTOMATIC FLUSH VALVE (REFER TO STANDARD MVLI-574I-0)
- ② DRIPPERLINE TO PVC CONNECTION (REFER TO STANDARD MVLI-574E-0)
- ③ LATERAL LINE (BURIED 12" MIN)
- ④ REMOTE CONTROL VALVE WITH FILTER AND PRESSURE REGULATING VALVE (REFER TO PLANS)
- ⑤ AREA PERIMETER
- ⑥ SOLID TUBING WITHOUT EMITTERS
- ⑦ DRIPPERLINE TUBING LATERAL - BURIED 3"-4" (SPACING AS SPECIFIED ON PLANS)
- ⑧ AIR/VACUUM RELIEF VALVE (REFER TO STANDARD MVLI-574K-0)

NOTES:

- 1.) SOIL STAPLE DRIPPERLINE TUBING AT 3' OC WITH NETAFIM TLS6.
- 2.) REFER TO STANDARD MVLI-574E-0 FOR DRIPPERLINE AND BELOW GROUND PVC CONNECTION.
- 3.) REFER TO STANDARD MVLI-574I-0 FOR AUTOMATIC FLUSH VALVE.
- 4.) REFER TO STANDARD MVLI-574K-0 FOR AIR/VACUUM RELIEF VALVE.

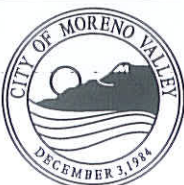
NOT TO SCALE



RECOMMENDED:
 1-16-14
 DIVISION MANAGER DATE
 APPROVED:
 1/29/14
 PUBLIC WORKS DIRECTOR/ DATE
 CITY ENGINEER

CITY OF MORENO VALLEY
 FINANCIAL & MANAGEMENT SERVICES DEPARTMENT - SPECIAL DISTRICTS DIVISION

**DRIPPERLINE
 (RECYCLED WATER SYSTEMS)
 CENTER FEED LAYOUT**

STANDARD PLAN
MVLI-574C-0
 SHEET 3 OF 12

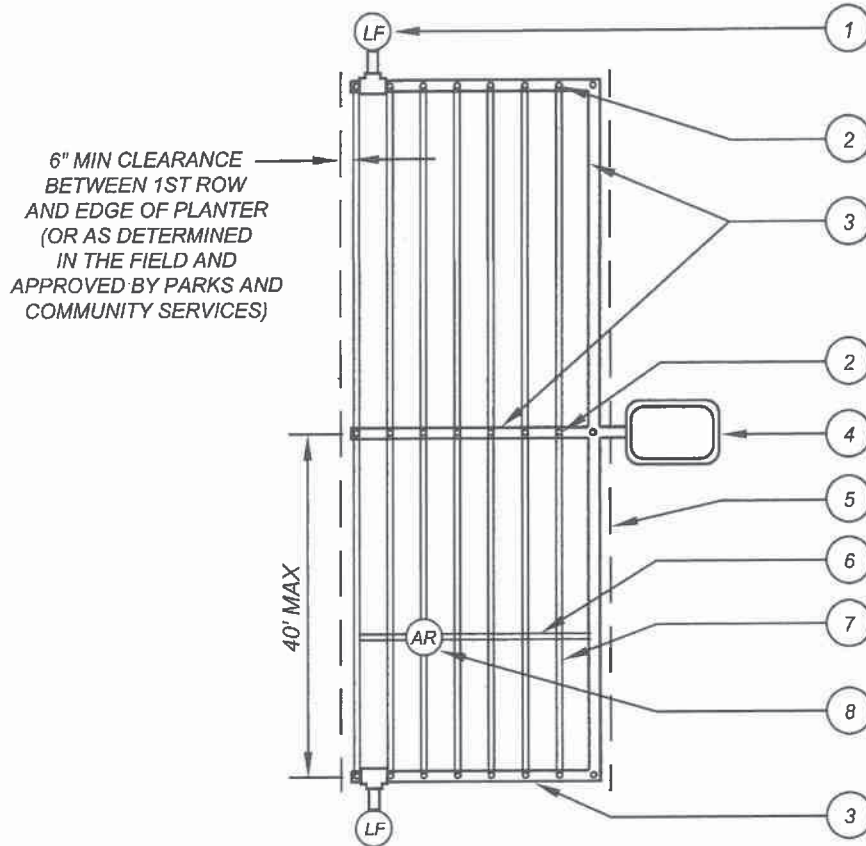

- ① AUTOMATIC FLUSH VALVE (REFER TO STANDARD MVLI-574J)
- ② DRIPPERLINE TO PVC CONNECTION (REFER TO STANDARD MVLI-574F) OR MANUFACTURER'S PRE-MADE DRIPLINE HEADER
- ③ LATERAL LINE (BURIED 12" MIN)
- ④ REMOTE CONTROL VALVE WITH FILTER AND PRESSURE REGULATING VALVE (REFER TO PLANS)
- ⑤ AREA PERIMETER
- ⑥ SOLID TUBING WITHOUT EMITTERS
- ⑦ DRIPPERLINE TUBING LATERAL - BURIED 2" (SPACING AS SPECIFIED ON PLANS)
- ⑧ AIR/VACUUM RELIEF VALVE (REFER TO STANDARD MVLI-574L)

NOTES:

- 1.) SOIL STAPLE DRIPPERLINE TUBING AT 3' OC WITH NETAFIM TLS6
- 2.) REFER TO STANDARD MVLI-574F FOR DRIPPERLINE AND BELOW GROUND PVC CONNECTION
- 3.) REFER TO STANDARD MVLI-574J FOR AUTOMATIC FLUSH VALVE
- 4.) REFER TO STANDARD MVLI-574L FOR AIR/VACUUM RELIEF VALVE

NOT TO SCALE

	RECOMMENDED: <i>[Signature]</i> DIVISION MANAGER DATE: 6/29/19	<h2 style="margin: 0;">CITY OF MORENO VALLEY</h2> <p style="margin: 0;">PARKS AND COMMUNITY SERVICES DEPARTMENT</p>	STANDARD PLAN MVLI-574D-0
	APPROVED: <i>[Signature]</i> PUBLIC WORKS DIRECTOR / CITY ENGINEER DATE: 7/30/19	<h3 style="margin: 0;">DRIPPERLINE (RECYCLED WATER SYSTEMS) CENTER FEED LAYOUT</h3>	

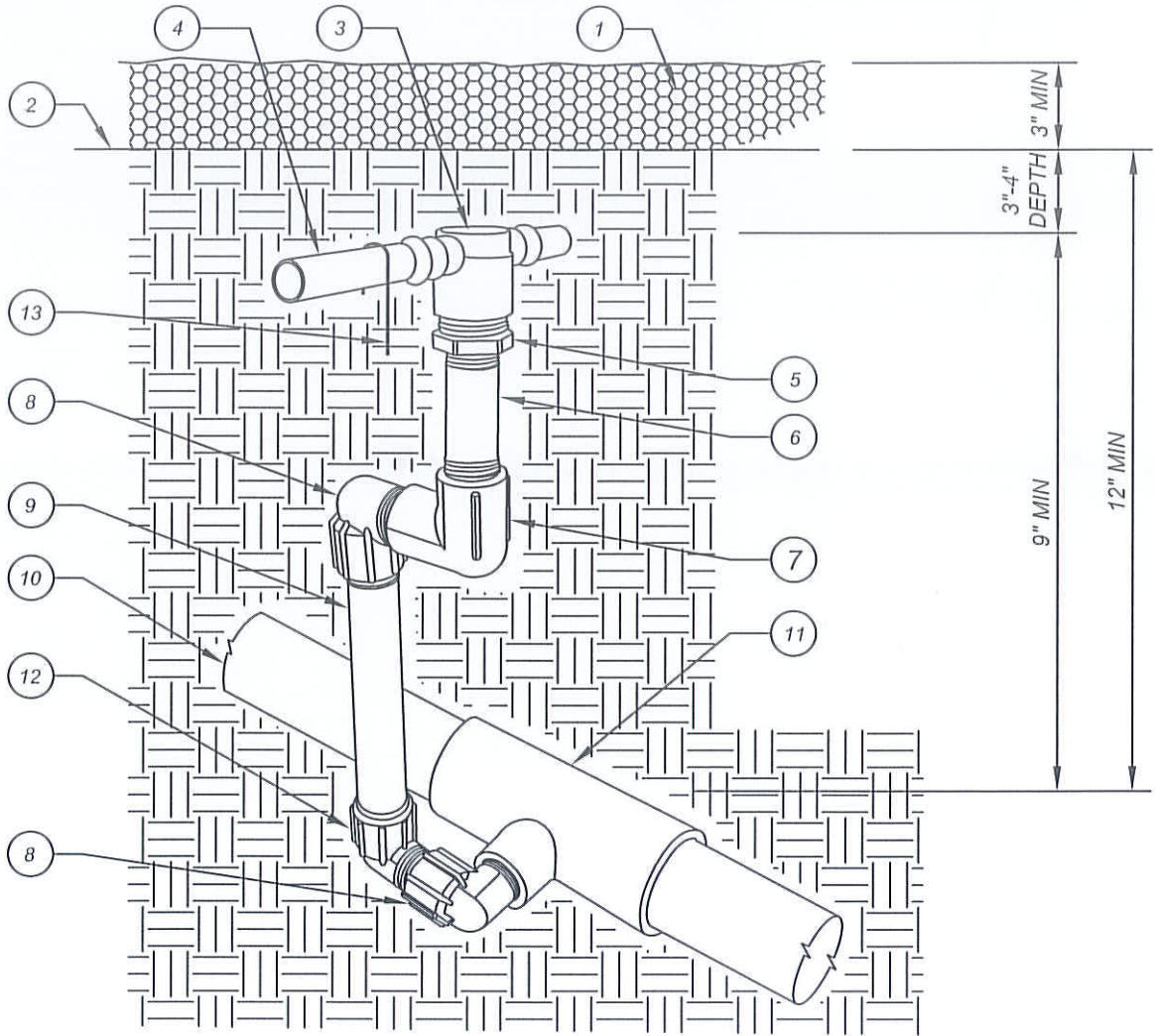

- 1 SHREDDED BARK / MULCH PER SPECIFICATIONS. 3" THICK COVERAGE MINIMUM
- 2 FINISH GRADE OF SOIL SURFACE
- 3 DRIPPERLINE COMBINATION TEE (INS x INS x 3/4" FPT) OR END CONNECTION AS APPLICABLE (1/2" PVC 90° ELL S x T WITH 1/2" MPT ADAPTER)
- 4 DRIPPERLINE TUBING PER PLANS
- 5 3/4" MIPT x 1/2" FIPT PVC REDUCER BUSHING
- 6 1/2" x 4" SCH 80 NIPPLE
- 7 1/2" PVC 90° ELL - FIPT x FIPT
- 8 1/2" MARLEX STREET ELL
- 9 1/2" x 6" SCH 80 NIPPLE
- 10 3/4" MIN PVC LATERAL LINE PER PLANS
- 11 PVC TEE (S x S x T) - SIZE PER PLANS
- 12 1/2" PVC STREET ELL
- 13 6" SOIL STABLE - PLACE APPROX EVERY 3' OF TUBING, PLUS 2 ON EACH TEE, ELL OR CROSS

NOTES: 1. ALL DRIPPERLINE FITTINGS SHALL BE OF THE SAME MANUFACTURE AS THE SPECIFIED DRIPPERLINE.
 2. USE TEFLON TAPE ON ALL PVC TO PVC CONNECTIONS.

NOT TO SCALE

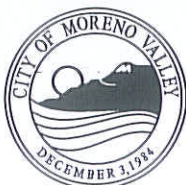

RECOMMENDED:
 [Signature] 1.16.14
 DIVISION MANAGER DATE
 APPROVED:
 [Signature] 1/29/14
 PUBLIC WORKS DIRECTOR/ DATE
 CITY ENGINEER

CITY OF MORENO VALLEY
 FINANCIAL & MANAGEMENT SERVICES DEPARTMENT - SPECIAL DISTRICTS DIVISION

PVC PIPE WITH SWING-JOINT CONNECTION TO DRIPPERLINE

STANDARD PLAN
MVLI-574E-0

SHEET 5 OF 12

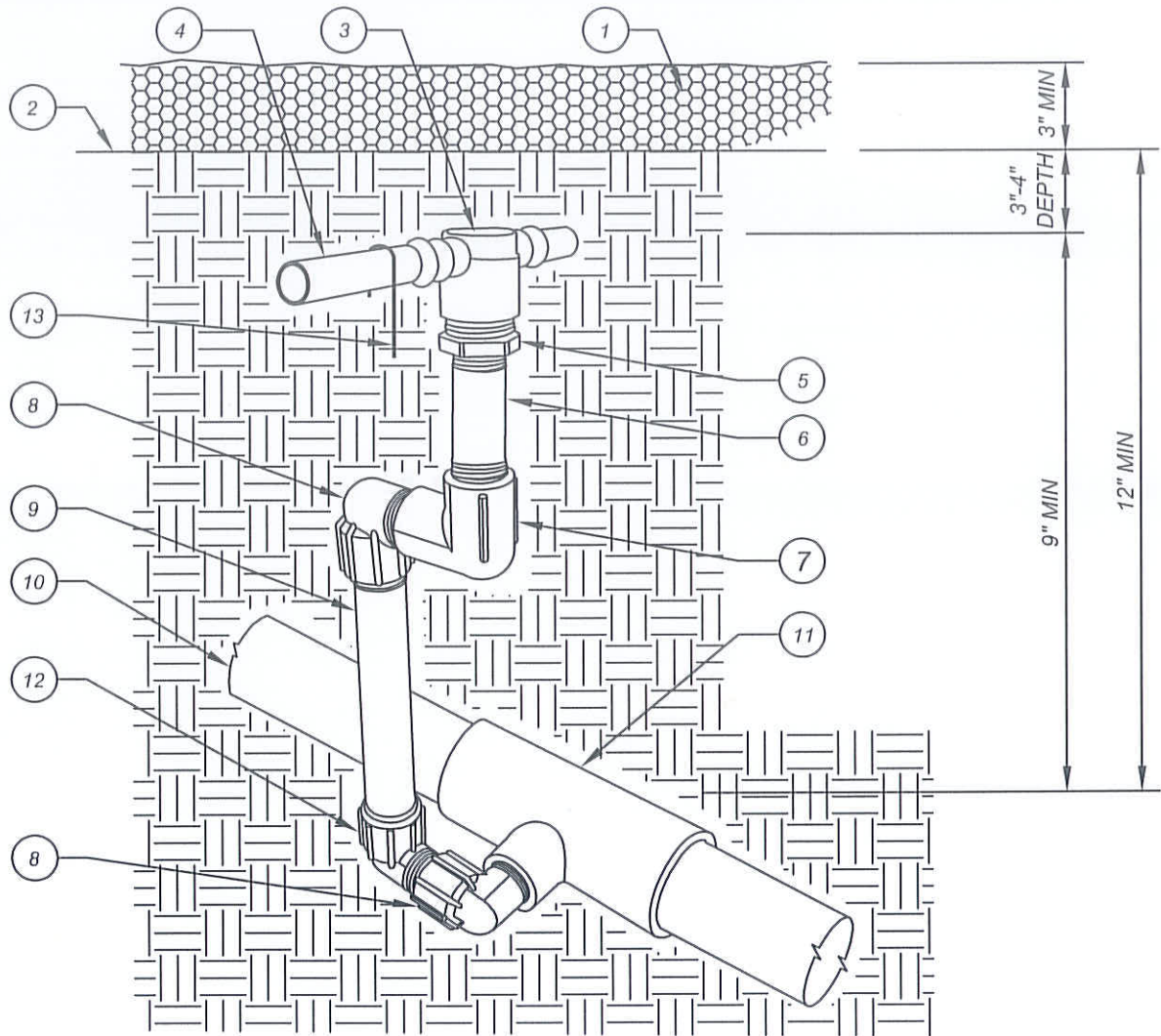

- | | | | |
|---|--|----|---|
| 1 | BARK / MULCH PER SPECIFICATIONS.
3" THICK COVERAGE MINIMUM | 7 | 1/2" PVC 90° ELL - FIPT x FIPT |
| 2 | FINISH GRADE OF SOIL SURFACE | 8 | 1/2" MARLEX STREET ELL |
| 3 | DRIPPERLINE COMBINATION TEE (1/2" x 1/2" x 3/4" FIPT)
OR END CONNECTION AS APPLICABLE (1/2" PVC
90° ELL S x T WITH 1/2" MPT ADAPTER) | 9 | 1/2" x 6" SCH 80 NIPPLE |
| 4 | DRIPPERLINE TUBING PER PLANS OR SPECS. | 10 | 3/4" MIN PVC LATERAL LINE PER PLANS |
| 5 | 3/4" MIPT x 1/2" FIPT PVC REDUCER BUSHING | 11 | PVC TEE (S x S x T) - SIZE PER PLANS |
| 6 | 1/2" x 4" SCH 80 NIPPLE | 12 | 1/2" PVC STREET ELL |
| | | 13 | 6" SOIL STABLE - PLACE APPROX EVERY 3' OF
TUBING, PLUS 2 ON EACH TEE, ELL OR CROSS |

NOTES: 1. ALL DRIPPERLINE FITTINGS SHALL BE OF THE SAME MANUFACTURE AS THE SPECIFIED DRIPPERLINE.
2. USE TEFLON TAPE ON ALL PVC TO PVC CONNECTIONS.

NOT TO SCALE

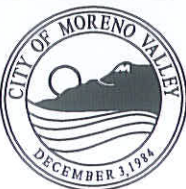

RECOMMENDED:

[Signature] 1/21/14
DIVISION MANAGER DATE

APPROVED:

[Signature] 1/29/14
PUBLIC WORKS DIRECTOR/ DATE
CITY ENGINEER

CITY OF MORENO VALLEY

PARKS AND COMMUNITY SERVICES DEPARTMENT

PVC PIPE WITH SWING-JOINT CONNECTION TO DRIPPERLINE

STANDARD PLAN

MVLI-574F-0

SHEET 6 OF 12

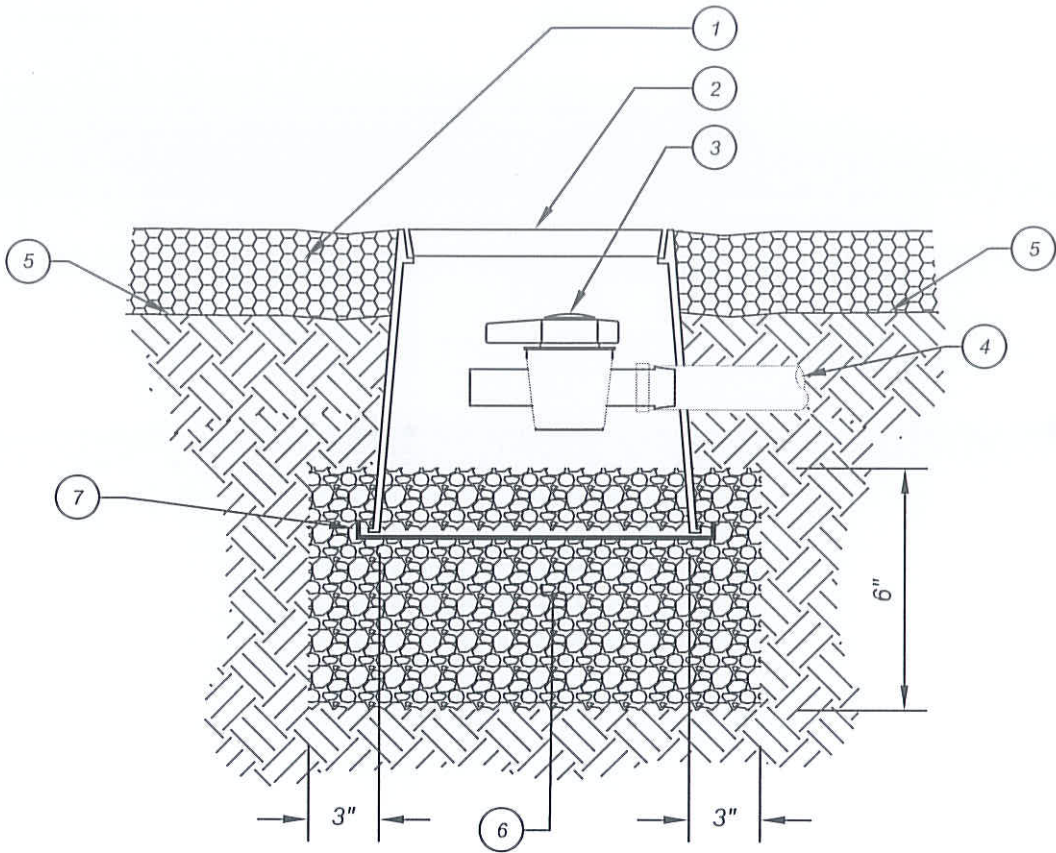

- ① FINISH SURFACE OF MULCH (3" THICK)
- ② 6" ROUND VALVE BOX. SEE NOTE BELOW
- ③ MANUAL SHUT-OFF VALVE (INS x INS)
- ④ DRIPPERLINE MANIFOLD CONNECTION
- ⑤ SOIL SURFACE FINISH GRADE, 3"-4" COVER OVER PIPE
- ⑥ 3/4" GRAVEL SUMP
- ⑦ 1/4" GALVANIZED WIRE MESH

NOTE:

TOP OF VALVE BOX TO BE INSTALLED 3" ABOVE FINISH GRADE IN PLANTER AREAS, AND EVEN WITH FINISH SURFACE OF MULCH.

NOT TO SCALE

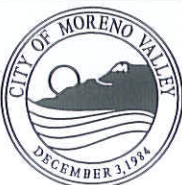

RECOMMENDED:
 1.16.14
 DIVISION MANAGER DATE

APPROVED:
 1/29/14
 PUBLIC WORKS DIRECTOR / DATE
 CITY ENGINEER

CITY OF MORENO VALLEY
 FINANCIAL & MANAGEMENT SERVICES DEPARTMENT - SPECIAL DISTRICTS DIVISION

**MANUAL SHUT-OFF / FLUSH VALVE
 (FOR DRIPPERLINE)**

STANDARD PLAN
MVLI-574G-0

SHEET 7 OF 12

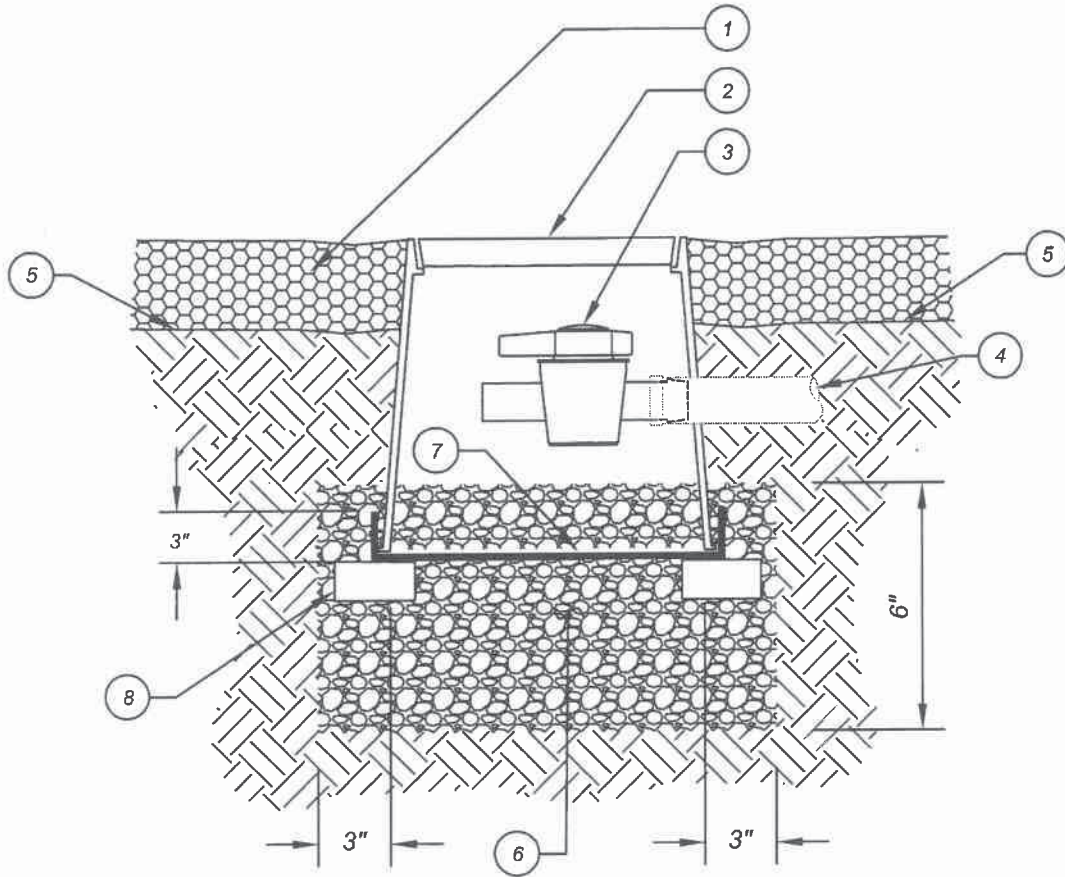



- 1 FINISH SURFACE OF MULCH (3" THICK)
- 2 10" ROUND VALVE BOX WITH SS BOLT AND WASHER. SEE NOTE BELOW
- 3 MANUAL SHUT-OFF VALVE (1/2" x 1/2")
- 4 DRIPPERLINE MANIFOLD CONNECTION
- 5 SOIL SURFACE FINISH GRADE, 3"-4" COVER OVER PIPE
- 6 3/4" GRAVEL SUMP
- 7 3/4" STAINLESS STEEL WIRE MESH, TYPE 316
- 8 CONCRETE PAVER SUPPORT (3 PER BOX)

NOTE:

TOP OF VALVE BOX TO BE INSTALLED 3" ABOVE FINISH GRADE IN PLANTER AREAS,
AND EVEN WITH FINISH SURFACE OF MULCH

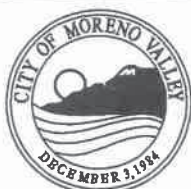
NOT TO SCALE

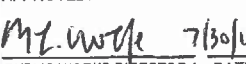

RECOMMENDED:

 DIVISION MANAGER DATE

APPROVED:

 PUBLIC WORKS DIRECTOR / DATE
 CITY ENGINEER

CITY OF MORENO VALLEY
 PARKS AND COMMUNITY SERVICES DEPARTMENT

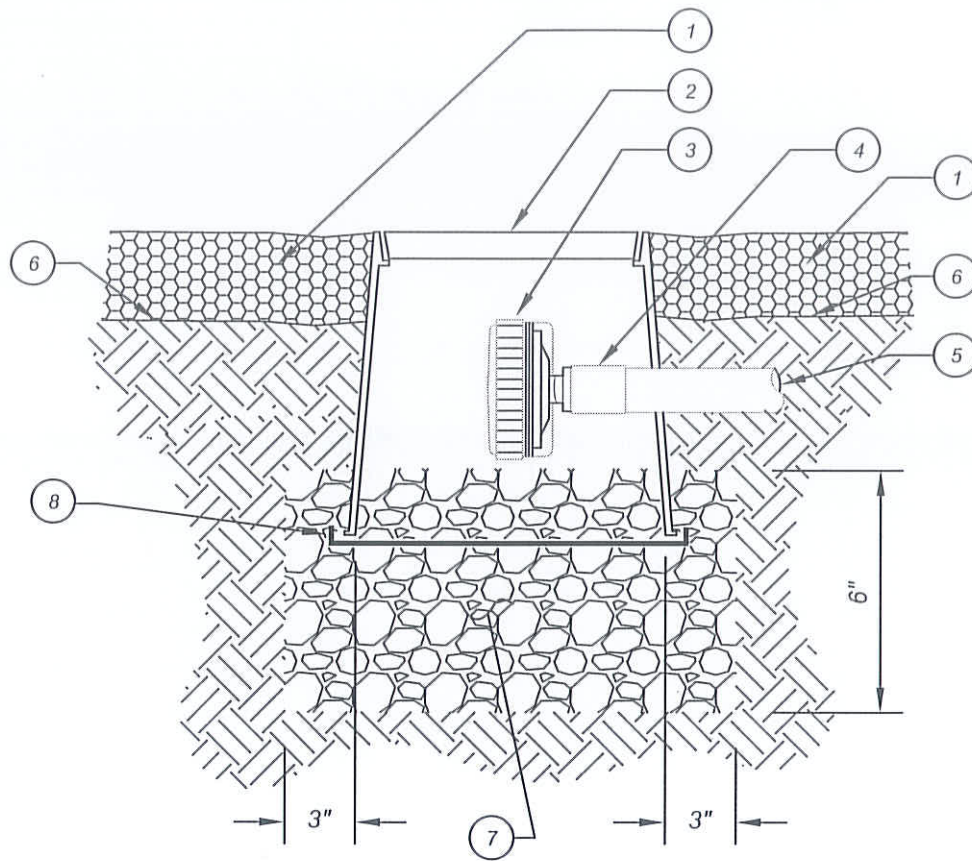
**MANUAL SHUT-OFF / FLUSH VALVE
 (FOR DRIPPERLINE)**

STANDARD PLAN
MVLI-574H-1
 SHEET 8 OF 12



- 1 FINISH SURFACE OF MULCH (3" THICK)
- 2 6" ROUND VALVE BOX. SEE NOTE BELOW
- 3 AUTOMATIC FLUSH VALVE
- 4 1/2" PVC COUP (FIPT x FIPT) WITH 1/2" MPT ADAPTER
- 5 DRIPPERLINE MANIFOLD CONNECTION
- 6 FINISH GRADE OF SOIL SURFACE, 3" - 4" COVER OVER PIPE
- 7 3/4" GRAVEL SUMP
- 8 1/4" GALVANIZED WIRE MESH

NOTE:

TOP OF VALVE BOX TO BE INSTALLED 3" ABOVE FINISH GRADE IN PLANTER AREAS, AND EVEN WITH FINISH SURFACE OF MULCH.

NOT TO SCALE



RECOMMENDED:
CS 1.16.14
 DIVISION MANAGER DATE
 APPROVED:
AM 1/29/14
 PUBLIC WORKS DIRECTOR DATE
 CITY ENGINEER

CITY OF MORENO VALLEY
 FINANCIAL & MANAGEMENT SERVICES DEPARTMENT - SPECIAL DISTRICTS DIVISION

**AUTOMATIC FLUSH VALVE
 (FOR DRIPPERLINE)**

STANDARD PLAN
MVLI-574I-0

SHEET 9 OF 12

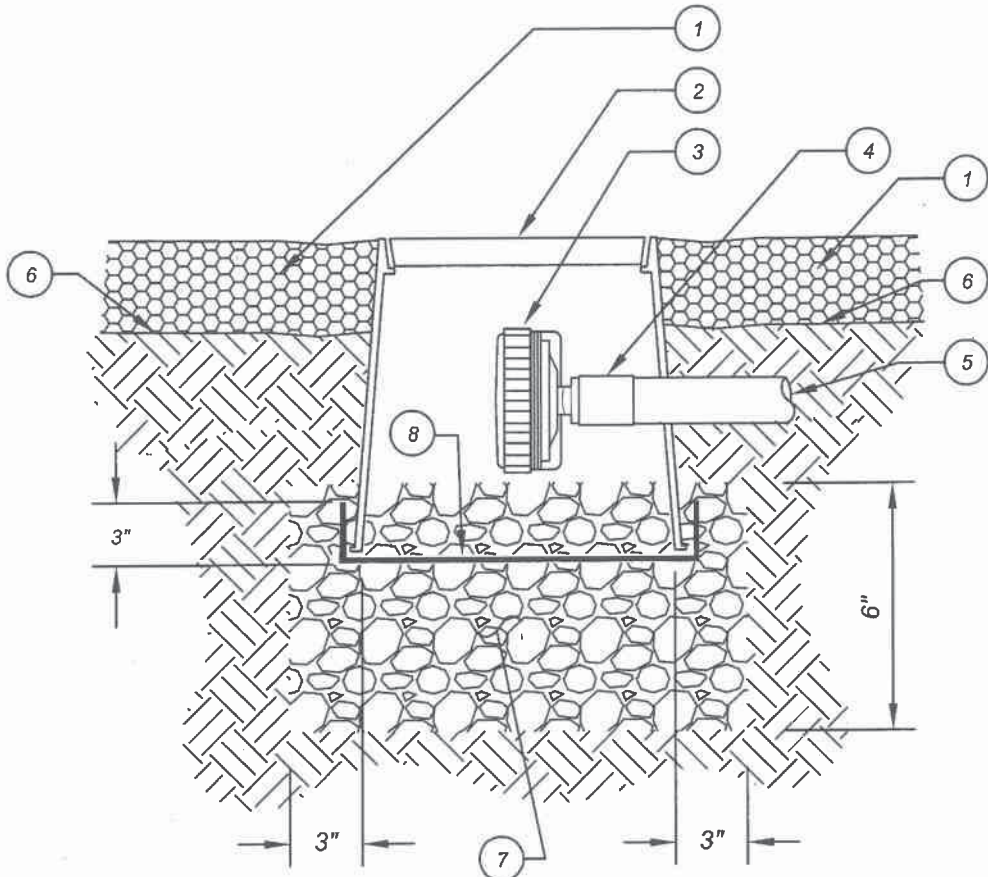

- ① FINISH SURFACE OF MULCH (3" THICK)
- ② 10" ROUND VALVE BOX WITH BOLT AND WASHER. SEE NOTE BELOW
- ③ AUTOMATIC FLUSH VALVE
- ④ 1/2" PVC COUP (FIPT x FIPT) WITH 1/2" MPT ADAPTER
- ⑤ DRIPPERLINE MANIFOLD CONNECTION
- ⑥ FINISH GRADE OF SOIL SURFACE, 3" - 4" COVER OVER PIPE
- ⑦ 3/4" GRAVEL SUMP
- ⑧ 1/4" STAINLESS STEEL WIRE MESH, TYPE 316

NOTE:

TOP OF VALVE BOX TO BE INSTALLED 3" ABOVE FINISH GRADE IN PLANTER AREAS, AND EVEN WITH FINISH SURFACE OF MULCH.

NOT TO SCALE

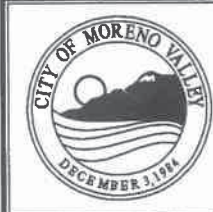

RECOMMENDED:
[Signature]
 DIVISION MANAGER DATE
 APPROVED:
Mt. wof 7/31/19
 PUBLIC WORKS DIRECTOR/ DATE
 CITY ENGINEER

CITY OF MORENO VALLEY
 PARKS AND COMMUNITY SERVICES DEPARTMENT

**AUTOMATIC FLUSH VALVE
 (FOR DRIPPERLINE)**

STANDARD PLAN
MVLI-574J-0
 SHEET 10 OF 12

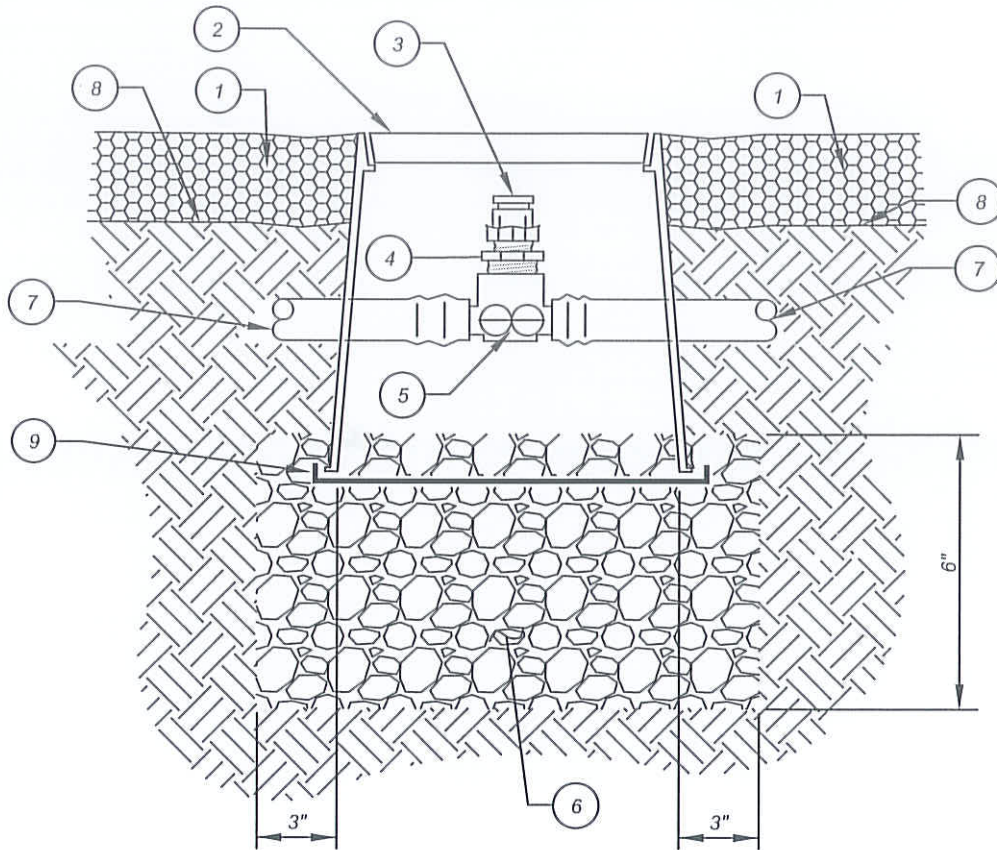



- 1 FINISH SURFACE OF MULCH (3" THICK)
- 2 6" ROUND VALVE BOX. SEE NOTE BELOW
- 3 AIR / VACUUM RELIEF VALVE
- 4 3/4" M x 1/2" F REDUCTION BUSHING
- 5 DRIPPERLINE COMBINATION TEE (1/2" x 1/2" x 3/4" FPT)
- 6 3/4" GRAVEL SUMP
- 7 DRIPPERLINE TUBING: FROM SURFACE INTO BOX TYPICAL
- 8 SOIL SURFACE FINISH GRADE, 3"-4" COVER OVER PIPE
- 9 1/4" GALVANIZED WIRE MESH

NOTE:

TOP OF VALVE BOX TO BE INSTALLED 3" ABOVE FINISH GRADE IN PLANTER AREAS, AND EVEN WITH FINISH SURFACE OF MULCH.

NOT TO SCALE



RECOMMENDED:

 DIVISION MANAGER DATE 1.16.14
 APPROVED:

 PUBLIC WORKS DIRECTOR / DATE 1/29/14
 CITY ENGINEER

CITY OF MORENO VALLEY
 FINANCIAL & MANAGEMENT SERVICES DEPARTMENT - SPECIAL DISTRICTS DIVISION

**AIR / VACUUM RELIEF VALVE
 (FOR DRIPPERLINE)**

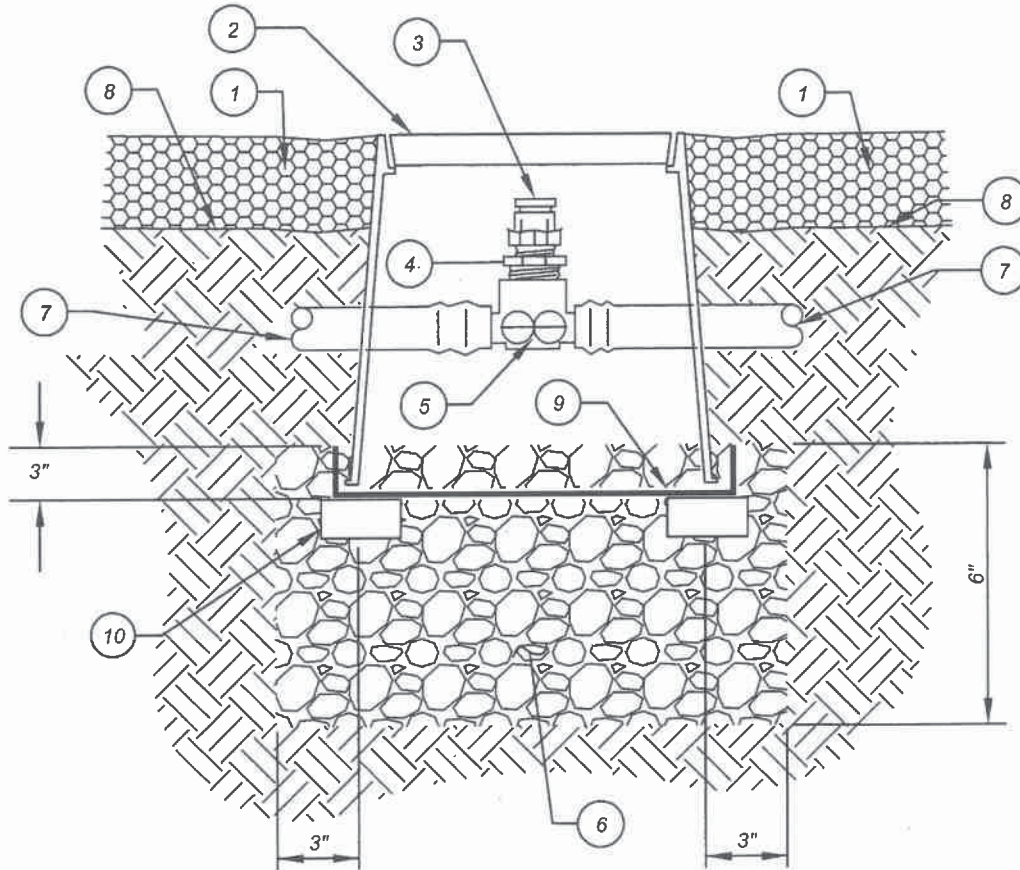
STANDARD PLAN
MVLI-574K-0

SHEET 11 OF 12



- 1 FINISH SURFACE OF MULCH (3" THICK)
- 2 6" ROUND VALVE BOX WITH BOLT AND WASHER. SEE NOTE BELOW
- 3 AIR / VACUUM RELIEF VALVE
- 4 3/4" M x 1/2" F REDUCTION BUSHING
- 5 DRIPPERLINE COMBINATION TEE (INS x INS x 3/4" FPT)
- 6 3/4" GRAVEL SUMP
- 7 DRIPPERLINE TUBING: FROM SURFACE INTO BOX TYPICAL
- 8 SOIL SURFACE FINISH GRADE, 3"-4" COVER OVER PIPE
- 9 1/4" STAINLESS STEEL WIRE MESH, TYPE 316
- 10 CONCRETE PAVER SUPPORT (3 PER BOX)

NOTE:

TOP OF VALVE BOX TO BE INSTALLED 3" ABOVE FINISH GRADE IN PLANTER AREAS, AND EVEN WITH FINISH SURFACE OF MULCH.

NOT TO SCALE



RECOMMENDED:

DIVISION MANAGER

DATE

APPROVED:

PUBLIC WORKS DIRECTOR /
CITY ENGINEER

DATE

CITY OF MORENO VALLEY

PARKS AND COMMUNITY SERVICES DEPARTMENT

AIR / VACUUM RELIEF VALVE (FOR DRIPPERLINE)

STANDARD PLAN

MVLI-574L-1

SHEET 12 OF 12

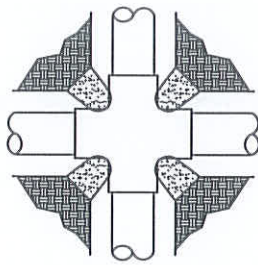

CROSS

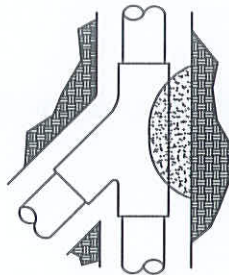

WYE

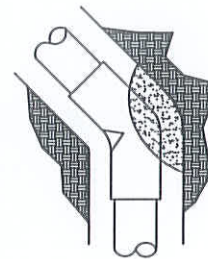

45 DEGREE ELBOW

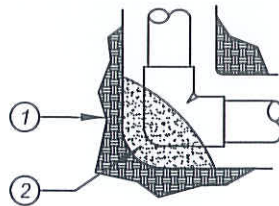

90 DEGREE TURN

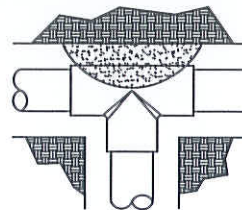

TEE

PLAN VIEW

LEGEND:

- ① SUBGRADE (TYPICAL)
- ② TYPICAL CONCRETE PLACEMENT

NOTES:

- 1) THRUST BLOCKS SHALL BE CLASS 560-C-3250 UNLESS OTHERWISE SPECIFIED.
- 2) SIZE AND TYPE OF THRUST BLOCKS SHALL BE SPECIFIED ON PLANS.

NOT TO SCALE

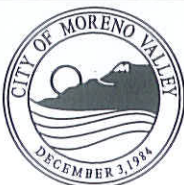

RECOMMENDED:
 1/16/14
 DIVISION MANAGER DATE

APPROVED:
 1/29/14
 PUBLIC WORKS DIRECTOR / DATE
 CITY ENGINEER

CITY OF MORENO VALLEY
 FINANCIAL & MANAGEMENT SERVICES DEPARTMENT - SPECIAL DISTRICTS DIVISION

THRUST BLOCKS

STANDARD PLAN
MVLI-580A-0

SHEET 1 OF 2

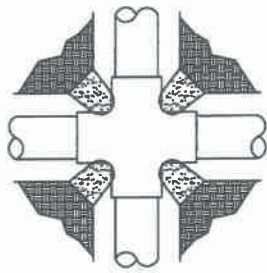

CROSS

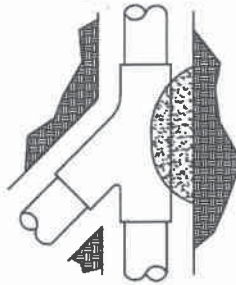

WYE



45 DEGREE ELBOW



90 DEGREE TURN

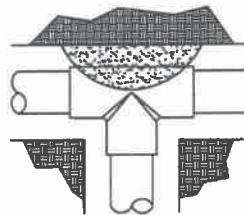

TEE

PLAN VIEW



LEGEND:

- ① SUBGRADE (TYPICAL)
- ② TYPICAL CONCRETE PLACEMENT

NOTES:

- 1.) THRUST BLOCKS SHALL BE 3000 PSI UNLESS OTHERWISE SPECIFIED
- 2.) SIZE AND TYPE OF THRUST BLOCKS SHALL BE SPECIFIED ON PLANS
- 3.) REQUIRED ON ALL MAINLINE, INCLUDING DUCTILE IRON FITTINGS

NOT TO SCALE

	RECOMMENDED:  DIVISION MANAGER	CITY OF MORENO VALLEY PARKS AND COMMUNITY SERVICES DEPARTMENT	STANDARD PLAN
	APPROVED:  7/30/09 PUBLIC WORKS DIRECTOR / DATE CITY ENGINEER		DATE: 7/30/09
			SHEET 2 OF 2

LEGEND:

- ① JUMBO OR LARGER RECTANGULAR VALVE BOX PER SPECS
- ② STANDARD RECTANGULAR VALVE BOX PER SPECS
- ③ 10" DIA ROUND VALVE BOX
- ④ EDGE OF AREA, CURB, WALK OR WALL

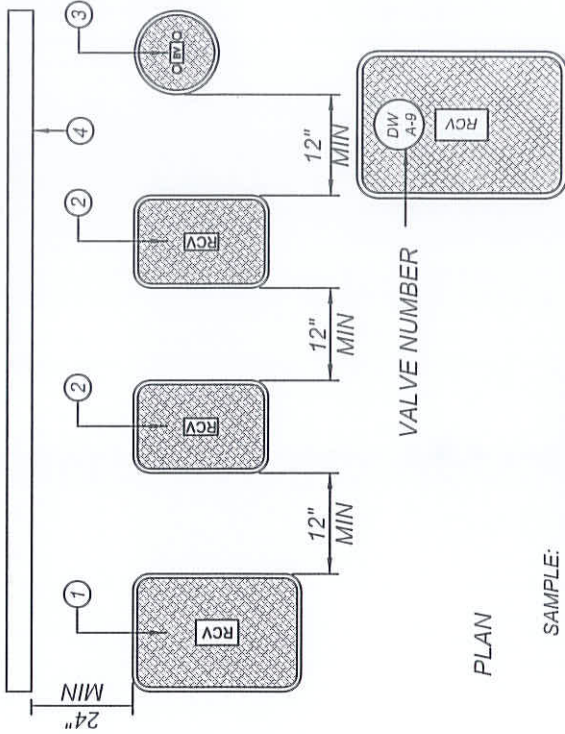

SAMPLE:
 POTABLE WATER SYSTEM OF
 CONTROLLER "A" REMOTE CONTROL
 VALVE ON STA No 9

NOTES:

- A- VALVE BOXES SHALL BE LABELED BY HOT IRON BRANDING, 2" LETTERS/NUMBERS
- B- CONTROL VALVES SHALL BE INSTALLED TO ALLOW ORDERLY ARRANGEMENT OF VALVE BOXES.
- C- WHERE POSSIBLE LOCATE VALVE ASSEMBLIES IN SHRUB OR GROUND COVER AREAS ONLY 12" FROM HARDSCAPE.
- D- LOCATION OF VALVE ASSEMBLIES SHALL BE STAKED FOR APPROVAL BY LANDSCAPE ARCHITECT PRIOR TO INSTALLATION.
- E- CENTER VALVE BOXES OVER VALVE ASSEMBLY TO FACILITATE ACCESS AND MAINTENANCE.
- F- SET VALVE BOXES AT EQUAL ELEVATIONS W/ TOPS AT 3" ABOVE FINISH GRADE IN SHRUB/ GROUND COVER AREAS.
- G- VALVE BOXES SHALL BE SET PARALLEL TO EACH OTHER AND PERPENDICULAR TO EDGE OF AREA.
- H- DO NOT DEFORM OR COLLAPSE VALVE BOX BY EXCESSIVE SOIL COMPACTION AROUND BOX.
- I- SEE ALSO INDIVIDUAL VALVE INSTALLATION DETAILS.

IDENTIFICATION GUIDE		EQUIPMENT DESIGNATION	CONTROLLER LEGEND	RECLAIMED WATER	DOMESTIC WATER
AIR RELIEF VALVE	ARV	A	RW	DW	
BASKET STRAINERS	BS	A	RW	DW	
BALL VALVE	BV	A	RW	DW	
COMMUNICATION SPLICES	CCC	A	RW	DW	
DRINKING FOUNTAIN	DF	A	RW	DW	
FLOW SENSORS	FS	A	RW	DW	
FLUSH VALVE ASSEMBLY	FVA	A	RW	DW	
GROUNDING RODS	GR	A	RW	DW	
GATE VALVES	GV	A	RW	DW	
XXXX	HB	A	RW	DW	
MOISTURE SENSORS	MS	A	RW	DW	
MASTER VALVE	MV	A	RW	DW	
PULL BOX	PB	A	RW	DW	
REMOTE CONTROL VALVES	(STA NO.)	A	RW	DW	
QUICK COUPLERS	QC	A	RW	DW	

CONTACT PARKS AND COMMUNITY SERVICES FOR INFO ON ANY DEVICE IN A BOX NOT LISTED.

NOT TO SCALE

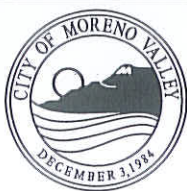

RECOMMENDED:
[Signature] 1/29/14
 DIVISION MANAGER DATE

APPROVED:
[Signature] 1/29/14
 PUBLIC WORKS DIRECTOR / DATE
 CITY ENGINEER

CITY OF MORENO VALLEY
 PARKS AND COMMUNITY SERVICES DEPARTMENT

BOX IDENTIFICATION

STANDARD PLAN
MVLI-581-0
 SHEET 1 OF 1

	<p>"CHRISTY" NO. 3150 MAXI-I.D. TAG IN BOTH ENGLISH AND SPANISH. USE IN ALL VALVE BOXES. USE PURPLE TAGS FOR RECLAIMED WATER OR FERTILIZER INSTECTOR SYSTEMS.</p>
<p>WARNING TAPE</p>	<p>"CHRISTY" 3" ND PRW NON-DETECTABLE PURPLE TAPE LABELED "CAUTION - RECLAIMED WATER BELOW" LOCATE ABOVE ALL MAINLINE</p>
<p>WARNING LABEL</p>	<p>"CHRISTY" NO. 4100 CONTROLLER UNIT LABEL - 3.5 MIL VINYL BASE (PURPLE) - ATTACH TO FACE OF CONTROLLER ENCL.</p>
<p>RISER LABEL</p>	<p>"CHRISTY" NO. 5100 RISER MARKER - 3.5 MIL VINYL BASE (PURPLE) - ATTACH TO IRRIGATION RISERS</p>

NOTES:

- 1.) THE CONTRACTOR MY OFFER ANY MATERIAL CONSIDERED TO BE EQUIVALENT TO THAT INDICATED.
THE SUBSTITUTION OF MATERIAL SHALL BE SUBMITTED IN WRITING AND APPROVED IN WRITING
BY THE CITY'S PROJECT MANAGER.

NOT TO SCALE

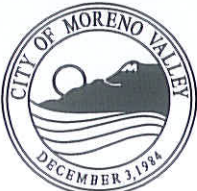
	<p>RECOMMENDED: <i>[Signature]</i> 1/21/14 DIVISION MANAGER DATE</p>	<p align="center">CITY OF MORENO VALLEY PARKS AND COMMUNITY SERVICES DEPARTMENT</p>	
	<p>APPROVED: <i>[Signature]</i> 1/29/14 PUBLIC WORKS DIRECTOR/ DATE CITY ENGINEER</p>		